



Wake Robin Inn Redevelopment

104 & 106 Sharon Road, Salisbury, Connecticut

Drainage Report

Prepared for:
Aradev LLC

352 Atlantic Avenue, Unit 2
Brooklyn, NY 11217

Prepared by:

SLR International Corporation

99 Realty Drive, Cheshire, Connecticut, 06410

SLR Project No.: 141.22100.00001

April 29, 2025

Revised July 28, 2025

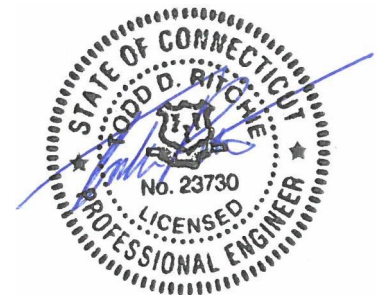

Drainage Report

Wake Robin Inn Redevelopment
104 & 106 Sharon Road
Salisbury, Connecticut
April 29, 2025
Revised July 28, 2025
SLR #141.22100.00001

This Drainage Report has been prepared in support of the proposed Wake Robin Inn redevelopment located on 104 & 106 Sharon Road/53 Wells Hill Road in the town of Salisbury, Connecticut. The development proposes to redevelop the existing Wake Robin Inn site with a building addition to the existing Inn, four cottages, an event space, a spa, a pool, and associated infrastructure including storage buildings, parking, drives, and walking trails.



Figure 1 – 104 & 106 Sharon Road



Table 1 – Stormwater Data

Parcel Size Total	13.79 acres
Existing Impervious Area (Watershed Area)	1.0 acres
Proposed Impervious Area (Watershed Area)	2.98 acres
Soil Type (Hydrologic Soil Group)	"B", "C", and "D"
Existing Land Use	Woods, open space, gravel, building, and driveway
Proposed Land Use	Woods, open space, gravel, building, and driveway
Design Storm for Stormwater Management	No increases in peak rates of runoff for the 2-, 10-, 25-, 50-, and 100-year storms Connecticut Department of Energy & Environmental Protection (CTDEEP) water quality volume (WQV) and water quality flow (WQF) treatment
Water Quality Measures	Catch basins with 2-foot sumps, hydrodynamic separator, retention storage for WQV
Design Storm for Storm Drainage	10-year storm
Federal Emergency Management Agency (FEMA) Special Flood Hazard Areas	Area of Minimal Flood Hazard (Zone X)
Connecticut Department of Energy & Environmental Protection Aquifer Protection Areas	Lakeville (Petee Street) – Level A

Stormwater Management Approach

The proposed stormwater management system for the project focuses on providing water quality management while attenuating proposed peak-flows. Water quality treatment in accordance with the CTDEEP requirements for water quality volume (WQV) and water quality flow (WQF) is provided. The proposed stormwater treatment train consists of catch basins with 2-foot sumps, a hydrodynamic separator, and retention storage for the WQV.

The computer program entitled *Hydraflow Storm Sewers Extension for AutoCAD® Civil 3D® 2023* by Autodesk, Inc. was used for designing the proposed storm drainage collection system. Storm drainage computations performed include pipe capacity and hydraulic grade line calculations. The contributing watershed to each individual catch basin inlet was delineated to determine the drainage area and land coverage. These values were used to determine the stormwater runoff to each inlet using the Rational Method. The rainfall intensities for the site were obtained from the National Oceanic and Atmospheric Administration (NOAA) Atlas 14, Volume 10, Precipitation Frequency Data Server (PFDS). The proposed storm drainage system



is designed to provide adequate capacity to convey the 10-year storm event.

Water Quality Management

Water quality measures or Best Management Practices (BMPs) have been incorporated into the design to maintain water quality to provide protection of the areas downgradient of the proposed development. The proposed stormwater management system will include catch basins with 2-foot sumps, a hydrodynamic separator, and retention storage for the WQV.

Each of the proposed stormwater basins will provide retention volume along its bottom, thus creating a water quality feature within it. This serves several purposes, including stormwater renovation and providing WQV. The CTDEEP *2024 Stormwater Quality Manual* (Chapter 7) recommends methods for sizing stormwater treatment measures with WQV computations. The WQV addresses the initial stormwater runoff, also commonly referred to as the "first-flush" runoff. The WQV provides adequate volume to store the runoff associated with the first 1.3 inches of rainfall, which tends to contain the highest concentration of potential pollutants.

A hydrodynamic separator will be installed in the proposed storm drainage system prior to discharging stormwater to Detention Basin 210. This unit will further remove suspended solids before discharging downgradient, which will in turn remove other pollutants that tend to attach to the suspended solids and effectively remove other debris and floatables that may be present in stormwater runoff. The hydrodynamic separator has been designed to meet criteria recommended by the CTDEEP *2024 Stormwater Quality Manual*. The device was designed based on the determined WQF, which is the peak-flow rate associated with the Water Quality Volume (WQV) and sized based on the manufacturer's specifications.

Hydrologic Analysis

A hydrologic analysis was conducted to analyze the pre-development and post-development peak-flow rates from the site. Three analysis points that receive runoff from the site were selected. Analysis Point A represents Wells Hill Road and the properties to the north of the site. Analysis Point B represents the existing storm drainage in Sharon Road adjacent to the site. Analysis Point C represents the properties southwest of the site and Sharon Road. The total watershed area delineated is approximately 25.2 acres under both existing and proposed conditions.

The method of predicting the surface water runoff rates utilized in this analysis was a computer program titled *HydroCAD 10.20-4a* by HydroCAD Software Solutions LLC. The *HydroCAD* program is a computer model that utilizes the methodologies set forth in the *Technical Release No. 55* (TR-55) manual and *Technical Release No. 20* (TR-20) computer model, originally developed by the United States Department of Agriculture – Natural Resources Conservation Service (USDA-NRCS). The *HydroCAD* computer modeling program is primarily used for conducting hydrology studies such as this one.

The *HydroCAD* computer program forecasts the rate of surface water runoff based upon several factors. The input data includes information on land use, hydrologic soil type, vegetation, contributing watershed area, time of concentration, rainfall data, storage volumes, and the hydraulic capacity of structures. The computer model predicts the amount of runoff as a function



of time, with the ability to include the attenuation effect due to dams, lakes, large wetlands, floodplains, and stormwater management basins. The input data for rainfalls with statistical recurrence frequencies of 1, 2, 5, 10, 25, 50, and 100 years was obtained from the NOAA Atlas 14, Volume 10 database. The corresponding rainfall totals are listed below.

Storm Frequency	Rainfall (inches)
1-year	2.41
2-year	3.08
5-year	4.19
10-year	5.11
25-year	6.37
50-year	7.28
100-year	8.32

Land use for the site under existing and proposed conditions was determined from field survey and aerial photogrammetry. Land use types used in the analysis included woods, grassed or open space, gravel, building, and impervious (paved) cover. Soil types in the watershed were determined from the CTDEEP Geographic Information System (GIS) database of the USDA-NRCS soil survey for Litchfield County, Connecticut. For the analysis, the site was determined to contain hydrologic soil types "B", "C", and "D" as classified by USDA-NRCS. Composite runoff Curve Numbers (CN) for each subwatershed were calculated based on the different land use and soil types. The time of concentration (Tc) was estimated for each subwatershed using the TR-55 methodology and was computed by summing all travel times through the watershed as sheet flow, shallow concentrated flow, and channel flow.

The existing conditions were modeled with the *HydroCAD* program to determine the peak-flow rates for the various storm events at each analysis point. A revised model was developed incorporating the proposed site conditions and stormwater management basins. The flows obtained with the revised model were then compared to the results of the existing conditions model. Peak-flow rates from the project site were controlled by the storage volume provided within the stormwater basins and their respective outlet control structures.

The following peak rates of runoff were obtained from the *HydroCAD* hydrology results:

Analysis Point A – Wells Hill Road							
	Peak Runoff Rate (cubic feet per second)						
Storm Frequency (years)	1	2	5	10	25	50	100
Existing Conditions	4.2	8.1	15.5	22.3	32.2	39.6	48.1
Proposed Conditions	4.0	7.8	14.9	21.5	31.0	38.0	46.3



Water Quality Basin 140**							
	Water Surface Elevation (feet)						
Storm Frequency (years)	1	2	5	10	25	50	100
Proposed Conditions	838.5	838.5	838.6	838.6	838.7	838.7	838.7

**Top of Berm Elevation = 839.0

Analysis Point B – Sharon Road Storm Drainage							
	Peak Runoff Rate (cubic feet per second)						
Storm Frequency (years)	1	2	5	10	25	50	100
Existing Conditions	3.9	6.1	10.1	13.5	18.2	21.6	25.5
Proposed Conditions	2.0	3.1	8.1	13.0	17.9	20.5	23.5

Detention Basin 210***							
	Water Surface Elevation (feet)						
Storm Frequency (years)	1	2	5	10	25	50	100
Proposed Conditions	815.6	815.9	816.1	816.2	816.6	816.8	817.1

***Top of Berm Elevation = 818.2

Detention Basin 220****							
	Water Surface Elevation (feet)						
Storm Frequency (years)	1	2	5	10	25	50	100
Proposed Conditions	802.1	802.4	802.7	802.9	802.9	803.0	803.0

****Top of Berm Elevation = 804.0

Analysis Point C – Sharon Road and Southern Properties							
	Peak Runoff Rate (cubic feet per second)						
Storm Frequency (years)	1	2	5	10	25	50	100
Existing Conditions	0.9	1.6	2.9	4.0	5.6	6.8	8.1
Proposed Conditions	0.7	1.2	2.1	2.8	3.9	4.7	5.7



Conclusion

The results of the hydrologic analysis demonstrate that there will be no increases in peak-flow rates from the proposed redevelopment. This was achieved for the storm events modeled through a planned stormwater management system with detention provided in the stormwater management basins. The proposed development will also introduce a new stormwater treatment train consisting of catch basins with 2-foot sumps, a hydrodynamic separator, and retention storage for the WQV.

All supporting documentation and stormwater-related computations are attached to this report along with the *HydroCAD* model results for stormwater management and *Hydraflow Storm Sewers* model results for the proposed storm drainage system. Illustrative Watershed Maps for both existing and proposed conditions are also attached to this report.

Appendices

Appendix A	United States Geological Survey Location Map
Appendix B	Federal Emergency Management Agency Flood Insurance Rate Map
Appendix C	Natural Resources Conservation Service Hydrologic Soil Group Map
Appendix D	Storm Drainage Computations
Appendix E	Water Quality Computations
Appendix F	Hydrologic Analysis – Input Computations
Appendix G	Hydrologic Analysis – Computer Model Results
Appendix H	Watershed Maps
Appendix I	Post-Construction Operation and Maintenance Manual



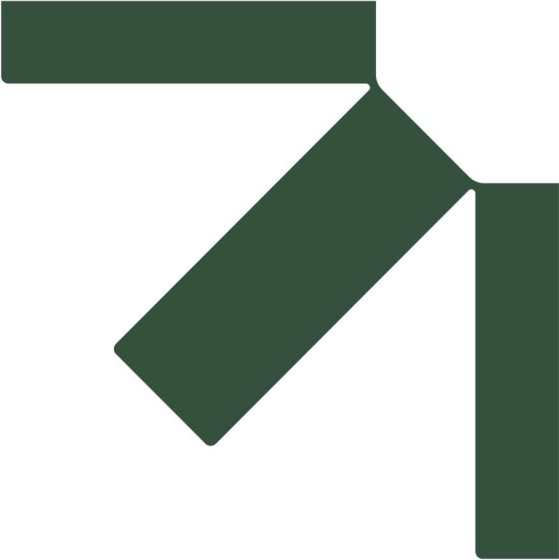

Appendix A United States Geological Survey Location Map

Wake Robin Inn Redevelopment

104 & 106 Sharon Road, Salisbury, Connecticut

Drainage Report

Prepared for:
Aradev LLC
352 Atlantic Avenue, Unit 2
Brooklyn, NY 11217

SLR Project No.: 141.22100.00001

April 25, 2025

Revised July 28, 2025



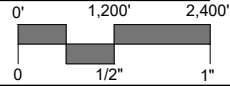
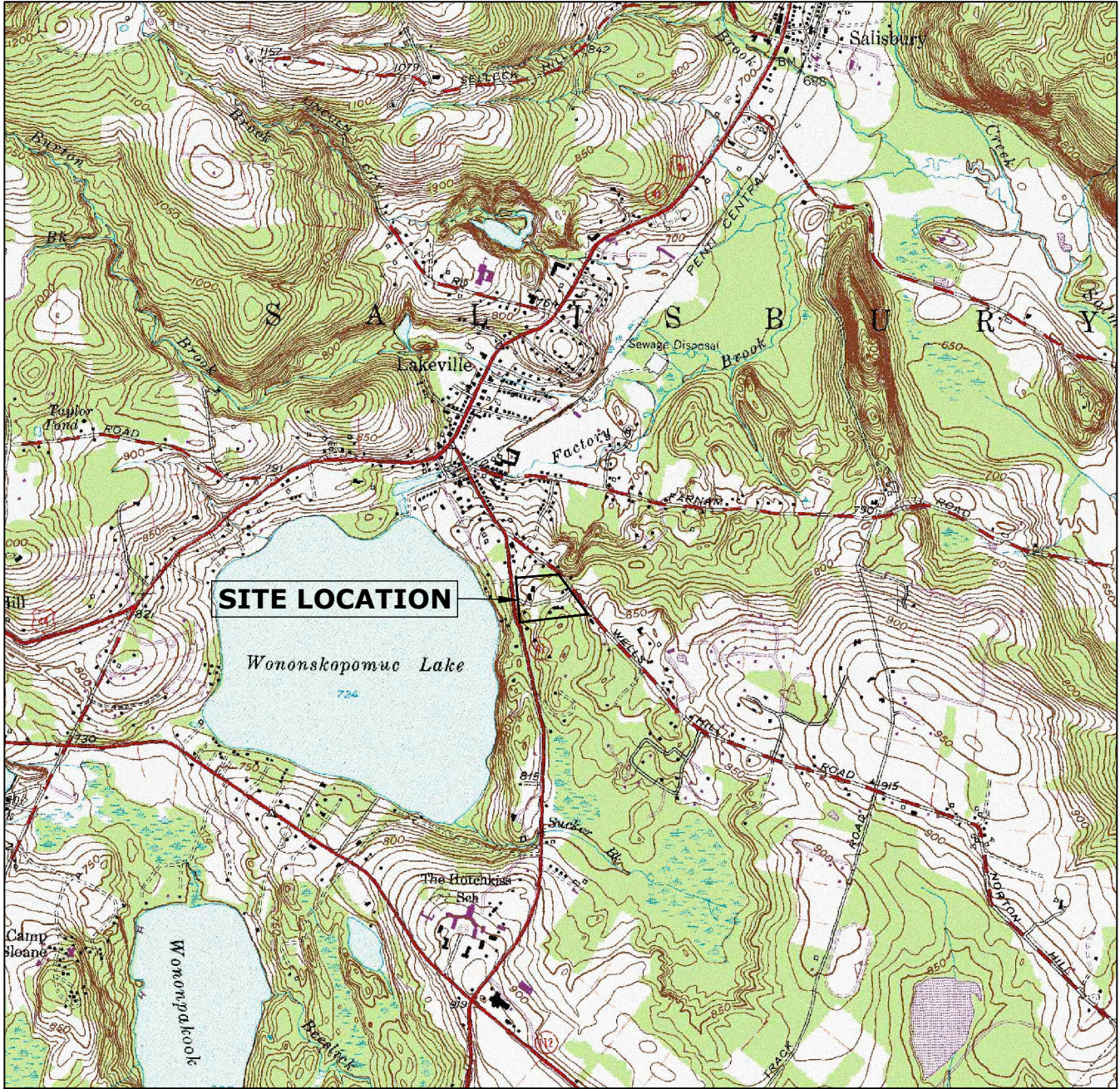
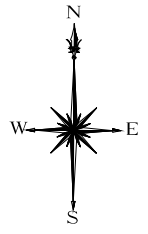

99 REALTY DRIVE
CHESHIRE, CT 06410
203.271.1773
SLRCONSULTING.COM

USGS QUADRANGLE MAP, QUAD NO. 16

**WAKE ROBIN
EVENT VENUE**

**104 AND 106 SHARON ROAD
SALISBURY, CONNECTICUT**

PROJECT PHASE:

REV: ---

DATE JULY 19, 2024		
SCALE 1"=2,400'		
PROJ. NO. 22100.00001		
DESIGNED ---	DRAWN MCB	CHECKED ---
DRAWING NAME: LOC		



Appendix B

FEMA Flood Insurance Rate Map

Wake Robin Inn Redevelopment

104 & 106 Sharon Road, Salisbury, Connecticut

Drainage Report

Prepared for:
Aradev LLC
352 Atlantic Avenue, Unit 2
Brooklyn, NY 11217

SLR Project No.: 141.22100.00001

April 25, 2025

Revised July 28, 2025



Agent or call the National Flood Insurance Program at (800) 538-6620.



APPROXIMATE SCALE

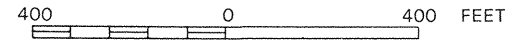

ZONE X

WELLS

HILL

ROAD

NATIONAL FLOOD INSURANCE PROGRAM

FIRM
FLOOD INSURANCE RATE MAP

TOWN OF
SALISBURY,
CONNECTICUT
LITCHFIELD COUNTY

PANEL 18 OF 30
(SEE MAP INDEX FOR PANELS NOT PRINTED)



PANEL LOCATION

COMMUNITY-PANEL NUMBER
090052 0018 B

EFFECTIVE DATE:
JANUARY 5, 1989



Federal Emergency Management Agency

This is an official FIRMette showing a portion of the above-referenced flood map created from the MSC FIRMette Web tool. This map does not reflect changes or amendments which may have been made subsequent to the date on the title block. For additional information about how to make sure the map is current, please see the Flood Hazard Mapping Updates Overview Fact Sheet available on the FEMA Flood Map Service Center home page at <https://msc.fema.gov>.



Appendix C

Natural Resources Conservation Service Hydrologic Soil Group Map

Wake Robin Inn Redevelopment

104 & 106 Sharon Road, Salisbury, Connecticut

Drainage Report

Prepared for:
Aradev LLC
352 Atlantic Avenue, Unit 2
Brooklyn, NY 11217

SLR Project No.: 141.22100.00001

April 25, 2025

Revised July 28, 2025



Hydrologic Soil Group—State of Connecticut, Western Part



Soil Map may not be valid at this scale.

Map Scale: 1:4,320 if printed on A landscape (11" x 8.5") sheet.

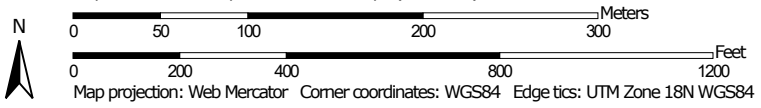

MAP LEGEND

Area of Interest (AOI)









 Area of Interest (AOI)

Soils

Soil Rating Polygons





 A
 A/D
 B
 B/D
 C
 C/D
 D
 Not rated or not available

Soil Rating Lines

 A
 A/D
 B
 B/D
 C
 C/D
 D
 Not rated or not available

Soil Rating Points





 A
 A/D
 B
 B/D

 C
 C/D
 D
 Not rated or not available

Water Features

 Streams and Canals

Transportation

 Rails
 Interstate Highways
 US Routes
 Major Roads
 Local Roads

Background

 Aerial Photography

MAP INFORMATION

The soil surveys that comprise your AOI were mapped at 1:12,000.

Warning: Soil Map may not be valid at this scale.

Enlargement of maps beyond the scale of mapping can cause misunderstanding of the detail of mapping and accuracy of soil line placement. The maps do not show the small areas of contrasting soils that could have been shown at a more detailed scale.

Please rely on the bar scale on each map sheet for map measurements.

Source of Map: Natural Resources Conservation Service
 Web Soil Survey URL:
 Coordinate System: Web Mercator (EPSG:3857)

Maps from the Web Soil Survey are based on the Web Mercator projection, which preserves direction and shape but distorts distance and area. A projection that preserves area, such as the Albers equal-area conic projection, should be used if more accurate calculations of distance or area are required.

This product is generated from the USDA-NRCS certified data as of the version date(s) listed below.

Soil Survey Area: State of Connecticut, Western Part
 Survey Area Data: Version 1, Sep 15, 2023

Soil map units are labeled (as space allows) for map scales 1:50,000 or larger.

Date(s) aerial images were photographed: Oct 21, 2022—Oct 27, 2022

The orthophoto or other base map on which the soil lines were compiled and digitized probably differs from the background imagery displayed on these maps. As a result, some minor shifting of map unit boundaries may be evident.

Hydrologic Soil Group

Map unit symbol	Map unit name	Rating	Acres in AOI	Percent of AOI
8	Mudgepond and Alden soils, extremely stony	C/D	1.5	2.3%
17	Timakwa and Natchaug soils, 0 to 2 percent slopes	B/D	0.1	0.1%
48B	Georgia and Amenia silt loams, 2 to 8 percent slopes	C/D	2.1	3.2%
49C	Georgia and Amenia silt loams, 8 to 15 percent slopes, very stony	C/D	0.2	0.3%
80B	Bernardston silt loam, 3 to 8 percent slopes	C	1.6	2.4%
80C	Bernardston silt loam, 8 to 15 percent slopes	C	0.1	0.2%
90B	Stockbridge loam, 3 to 8 percent slopes	B	7.4	11.3%
90C	Stockbridge loam, 8 to 15 percent slopes	B	6.2	9.4%
94C	Farmington-Nellis complex, 3 to 15 percent slopes, very rocky	D	41.0	62.3%
94E	Farmington-Nellis complex, 15 to 35 percent slopes, very rocky	D	1.7	2.6%
95E	Farmington-Rock outcrop complex, 15 to 45 percent slopes	D	3.9	6.0%
Totals for Area of Interest			65.9	100.0%

Description

Hydrologic soil groups are based on estimates of runoff potential. Soils are assigned to one of four groups according to the rate of water infiltration when the soils are not protected by vegetation, are thoroughly wet, and receive precipitation from long-duration storms.

The soils in the United States are assigned to four groups (A, B, C, and D) and three dual classes (A/D, B/D, and C/D). The groups are defined as follows:

Group A. Soils having a high infiltration rate (low runoff potential) when thoroughly wet. These consist mainly of deep, well drained to excessively drained sands or gravelly sands. These soils have a high rate of water transmission.

Group B. Soils having a moderate infiltration rate when thoroughly wet. These consist chiefly of moderately deep or deep, moderately well drained or well drained soils that have moderately fine texture to moderately coarse texture. These soils have a moderate rate of water transmission.

Group C. Soils having a slow infiltration rate when thoroughly wet. These consist chiefly of soils having a layer that impedes the downward movement of water or soils of moderately fine texture or fine texture. These soils have a slow rate of water transmission.

Group D. Soils having a very slow infiltration rate (high runoff potential) when thoroughly wet. These consist chiefly of clays that have a high shrink-swell potential, soils that have a high water table, soils that have a claypan or clay layer at or near the surface, and soils that are shallow over nearly impervious material. These soils have a very slow rate of water transmission.

If a soil is assigned to a dual hydrologic group (A/D, B/D, or C/D), the first letter is for drained areas and the second is for undrained areas. Only the soils that in their natural condition are in group D are assigned to dual classes.

Rating Options

Aggregation Method: Dominant Condition

Component Percent Cutoff: None Specified

Tie-break Rule: Higher



Appendix D

Storm Drainage Computations

Wake Robin Inn Redevelopment

104 & 106 Sharon Road, Salisbury, Connecticut

Drainage Report

Prepared for:
Aradev LLC
352 Atlantic Avenue, Unit 2
Brooklyn, NY 11217

SLR Project No.: 141.22100.00001

April 25, 2025

Revised July 28, 2025



Rational Method Individual Basin Calculations

Project: Wake Robin Inn
 Location: Salisbury, CT

By: MCB
 Checked: TDR

Date: Rev. 4/17/25
 Date: 4/17/25

Basin Name	Impervious Area C=0.9 (sf)	Grassed Area C=0.3 (sf)	Wooded Area C=0.2 (sf)	Total Area (sf)	Total Area (ac)	Weighted C	Tc (min)
System 200							
YD 6	1350	1881	19731	22962	0.53	0.25	5.0
MH 7	0	1194	0	1194	0.03	0.30	5.0
YD 9	4757	3315	1314	9386	0.22	0.59	5.0
CLCB 10	1623	161	0	1784	0.04	0.85	5.0
CLCB 28	3921	1595	12008	17524	0.40	0.37	5.0
YD 29	0	5701	2907	8608	0.20	0.27	5.0
MH 30	1207	8699	0	9906	0.23	0.37	5.0
YD 31	1966	521	0	2487	0.06	0.77	5.0
FES 31A	4555	14672	16055	35282	0.81	0.33	5.0
YD 61	0	3530	0	3530	0.08	0.30	5.0
CLCB 27A	5343	0	0	5343	0.12	0.90	5.0
System 210							
CLCB 14	4319	2904	0	7223	0.17	0.66	5.0
CLCB 15	3555	1466	0	5021	0.12	0.72	5.0
CLCB 16	3768	3488	0	7256	0.17	0.61	5.0
YD 17	1328	2727	0	4055	0.09	0.50	5.0
YD 58	298	341	0	639	0.01	0.58	5.0
CLCB 59	4992	1469	0	6461	0.15	0.76	5.0
YD 62	1076	4845	0	5921	0.14	0.41	5.0
YD 60	647	485	0	1132	0.03	0.64	5.0
YD 72	8936	9863	4345	23144	0.53	0.51	5.0
TD 13A	3368	408	0	3776	0.09	0.84	5.0
YD 74	1181	1111	0	2292	0.05	0.61	5.0
System 220							
YD 24	2279	4080	0	6359	0.15	0.52	5.0
Bridge							
Bridge	25313	70952	483320	579585	13.31	0.24	38.8

Rational Method Roof Drain System Calculations

Project: Wake Robin Inn
 Location: Salisbury, CT

By: MCB
 Checked: TDR

Date: Rev. 4/17/25
 Date: 4/17/25

Total Roof Runoff to Proposed Storm Drainage System (In Hydraflow Model)

	ROOF TO CLCB 16	ROOF TO YD 72	ROOF TO YD 24	ROOF TO CLCB 59	FES 31A	Bridge (100- Year Tc=38.3 min)	
C	0.90	0.90	0.90	0.90	0.33	0.24	
I	6.98	6.98	6.98	6.98	10.50	3.63	
A	0.37	0.04	0.02	0.18	0.81	13.31	
Q	2.31	0.25	0.12	1.14	2.81	11.60	



POINT PRECIPITATION FREQUENCY ESTIMATES

Sanja Perica, Sandra Pavlovic, Michael St. Laurent, Carl Trypaluk, Dale Unruh, Orlan Wilhite

NOAA, National Weather Service, Silver Spring, Maryland

[PF_tabular](#) | [PF_graphical](#) | [Maps & aerials](#)

PF tabular

PDS-based point precipitation frequency estimates with 90% confidence intervals (in inches/hour)¹										
Duration	Average recurrence interval (years)									
	1	2	5	10	25	50	100	200	500	1000
5-min	4.01 (3.06-5.24)	4.75 (3.64-6.22)	5.96 (4.55-7.84)	6.97 (5.29-9.22)	8.36 (6.16-11.5)	9.42 (6.80-13.2)	10.5 (7.37-15.3)	11.7 (7.82-17.4)	13.3 (8.60-20.6)	14.6 (9.23-23.0)
10-min	2.84 (2.17-3.71)	3.37 (2.57-4.40)	4.23 (3.23-5.56)	4.94 (3.74-6.53)	5.93 (4.36-8.15)	6.67 (4.81-9.38)	7.44 (5.22-10.8)	8.27 (5.54-12.4)	9.41 (6.09-14.6)	10.3 (6.53-16.3)
15-min	2.22 (1.70-2.91)	2.64 (2.02-3.46)	3.32 (2.52-4.36)	3.88 (2.94-5.12)	4.65 (3.42-6.40)	5.23 (3.77-7.35)	5.84 (4.09-8.48)	6.48 (4.35-9.69)	7.38 (4.78-11.4)	8.10 (5.12-12.8)
30-min	1.53 (1.17-2.00)	1.81 (1.39-2.37)	2.28 (1.74-3.00)	2.67 (2.02-3.53)	3.20 (2.36-4.41)	3.61 (2.60-5.07)	4.03 (2.83-5.87)	4.49 (3.01-6.71)	5.15 (3.33-7.96)	5.68 (3.59-8.97)
60-min	0.971 (0.743-1.27)	1.15 (0.882-1.51)	1.45 (1.11-1.91)	1.70 (1.29-2.25)	2.04 (1.50-2.82)	2.30 (1.66-3.24)	2.57 (1.81-3.75)	2.87 (1.92-4.29)	3.30 (2.13-5.11)	3.65 (2.31-5.77)
2-hr	0.638 (0.490-0.831)	0.740 (0.568-0.965)	0.907 (0.694-1.19)	1.05 (0.796-1.38)	1.24 (0.913-1.69)	1.38 (1.00-1.93)	1.53 (1.08-2.21)	1.69 (1.14-2.52)	1.91 (1.24-2.95)	2.09 (1.32-3.29)
3-hr	0.488 (0.376-0.634)	0.566 (0.435-0.735)	0.692 (0.531-0.902)	0.797 (0.608-1.04)	0.941 (0.697-1.29)	1.05 (0.763-1.46)	1.16 (0.821-1.68)	1.29 (0.867-1.91)	1.46 (0.948-2.24)	1.60 (1.02-2.51)
6-hr	0.299 (0.231-0.387)	0.354 (0.274-0.458)	0.444 (0.342-0.577)	0.519 (0.398-0.678)	0.622 (0.464-0.851)	0.698 (0.512-0.979)	0.781 (0.559-1.14)	0.879 (0.594-1.30)	1.03 (0.669-1.58)	1.15 (0.734-1.80)
12-hr	0.174 (0.135-0.224)	0.216 (0.167-0.278)	0.284 (0.220-0.367)	0.340 (0.262-0.442)	0.418 (0.315-0.575)	0.475 (0.352-0.670)	0.538 (0.392-0.797)	0.620 (0.419-0.919)	0.753 (0.491-1.16)	0.870 (0.557-1.36)
24-hr	0.100 (0.078-0.128)	0.128 (0.100-0.164)	0.174 (0.135-0.224)	0.212 (0.164-0.275)	0.265 (0.201-0.364)	0.303 (0.227-0.429)	0.346 (0.255-0.516)	0.404 (0.274-0.597)	0.501 (0.328-0.766)	0.587 (0.377-0.916)
2-day	0.057 (0.044-0.072)	0.073 (0.057-0.093)	0.100 (0.078-0.128)	0.123 (0.095-0.158)	0.153 (0.117-0.210)	0.176 (0.132-0.248)	0.201 (0.149-0.299)	0.235 (0.160-0.346)	0.292 (0.191-0.445)	0.343 (0.221-0.533)
3-day	0.041 (0.032-0.052)	0.053 (0.042-0.067)	0.072 (0.057-0.092)	0.088 (0.069-0.113)	0.110 (0.084-0.151)	0.126 (0.095-0.178)	0.144 (0.107-0.214)	0.169 (0.115-0.248)	0.210 (0.138-0.319)	0.246 (0.159-0.382)
4-day	0.033 (0.026-0.042)	0.042 (0.033-0.054)	0.058 (0.045-0.074)	0.070 (0.055-0.090)	0.088 (0.067-0.120)	0.100 (0.076-0.141)	0.115 (0.085-0.170)	0.134 (0.091-0.197)	0.166 (0.109-0.252)	0.195 (0.126-0.302)
7-day	0.022 (0.018-0.028)	0.028 (0.022-0.036)	0.038 (0.030-0.048)	0.046 (0.036-0.059)	0.057 (0.044-0.078)	0.065 (0.049-0.091)	0.074 (0.055-0.109)	0.086 (0.059-0.126)	0.106 (0.070-0.161)	0.123 (0.080-0.191)
10-day	0.018 (0.014-0.023)	0.023 (0.018-0.029)	0.030 (0.023-0.038)	0.036 (0.028-0.045)	0.044 (0.033-0.059)	0.050 (0.037-0.069)	0.056 (0.042-0.082)	0.065 (0.044-0.095)	0.079 (0.052-0.120)	0.091 (0.059-0.141)
20-day	0.013 (0.010-0.016)	0.015 (0.012-0.019)	0.019 (0.015-0.024)	0.022 (0.017-0.028)	0.026 (0.020-0.035)	0.030 (0.022-0.041)	0.033 (0.024-0.047)	0.037 (0.026-0.054)	0.044 (0.029-0.066)	0.049 (0.032-0.076)
30-day	0.011 (0.009-0.014)	0.012 (0.010-0.016)	0.015 (0.012-0.019)	0.017 (0.013-0.022)	0.020 (0.015-0.027)	0.022 (0.017-0.030)	0.024 (0.018-0.035)	0.027 (0.019-0.039)	0.031 (0.021-0.047)	0.034 (0.022-0.053)
45-day	0.009 (0.007-0.011)	0.010 (0.008-0.013)	0.012 (0.009-0.015)	0.013 (0.011-0.017)	0.015 (0.012-0.020)	0.017 (0.013-0.023)	0.019 (0.013-0.026)	0.020 (0.014-0.029)	0.022 (0.015-0.034)	0.024 (0.016-0.037)
60-day	0.008 (0.006-0.010)	0.009 (0.007-0.011)	0.010 (0.008-0.013)	0.011 (0.009-0.014)	0.013 (0.010-0.017)	0.014 (0.010-0.019)	0.015 (0.011-0.021)	0.016 (0.011-0.024)	0.018 (0.012-0.027)	0.019 (0.012-0.029)

¹ Precipitation frequency (PF) estimates in this table are based on frequency analysis of partial duration series (PDS). Numbers in parenthesis are PF estimates at lower and upper bounds of the 90% confidence interval. The probability that precipitation frequency estimates (for a given duration and average recurrence interval) will be greater than the upper bound (or less than the lower bound) is 5%. Estimates at upper bounds are not checked against probable maximum precipitation (PMP) estimates and may be higher than currently valid PMP values. Please refer to NOAA Atlas 14 document for more information.

[Back to Top](#)

PF graphical

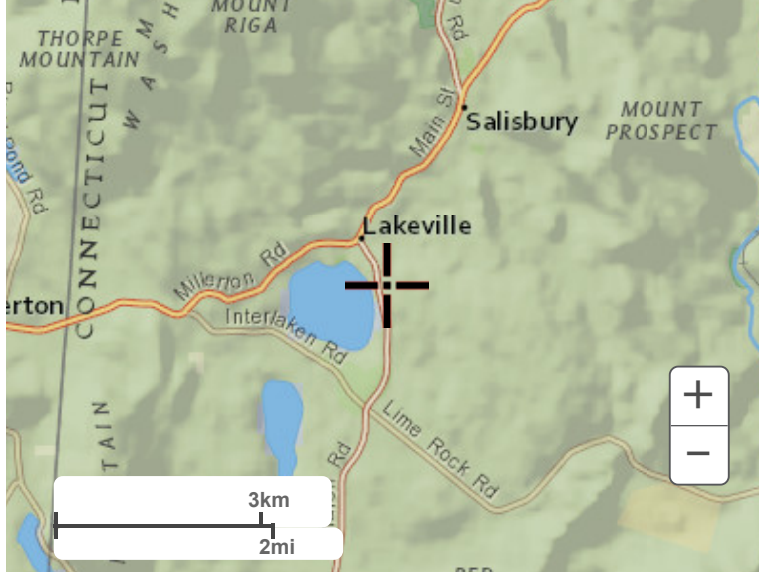

Large scale terrain



Large scale map

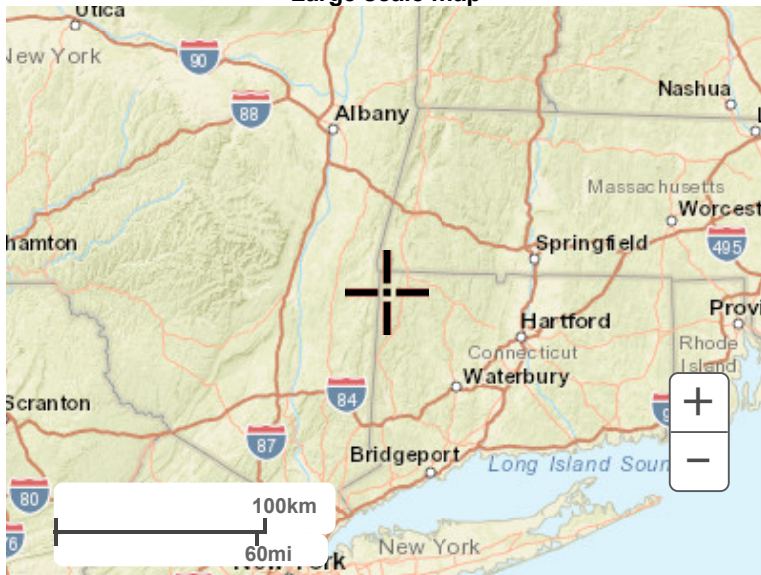

Large scale aerial

Storm Sewer IDF Curves

IDF file: Salisbury.IDF

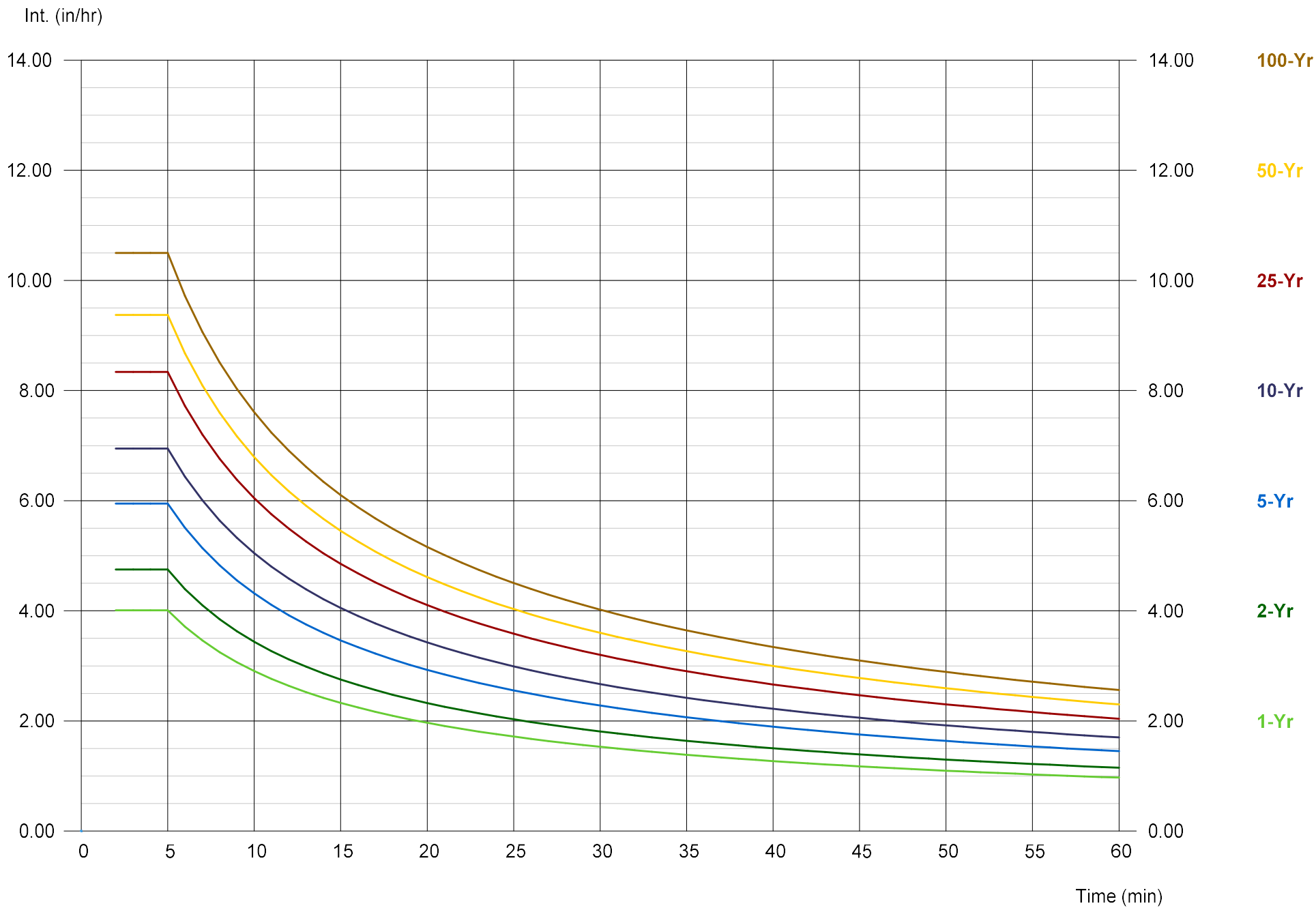

Hydraflow Storm Sewers Extension for Autodesk® Civil 3D® Plan

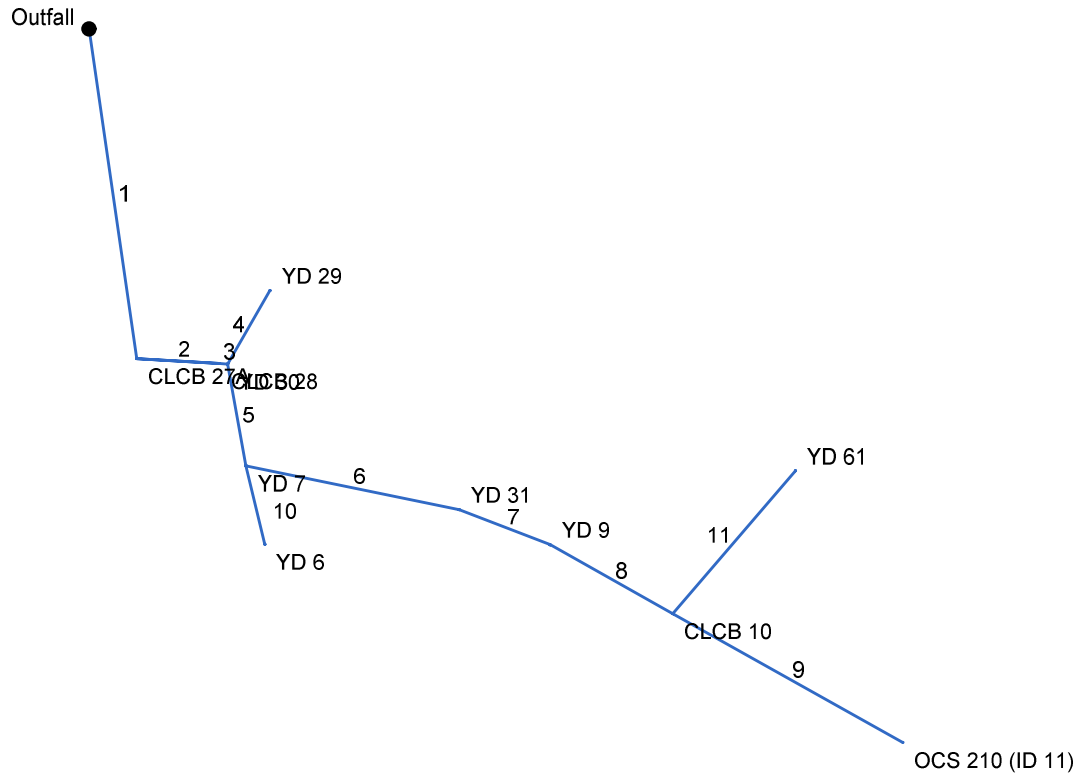

Storm Sewer Inventory Report

Line No.	Alignment				Flow Data				Physical Data								Line ID
	Dnstr Line No.	Line Length (ft)	Defl angle (deg)	Junc Type	Known Q (cfs)	Drng Area (ac)	Runoff Coeff (C)	Inlet Time (min)	Invert El Dn (ft)	Line Slope (%)	Invert El Up (ft)	Line Size (in)	Line Shape	N Value (n)	J-Loss Coeff (K)	Inlet/ Rim El (ft)	
1	End	161.000	81.800	Grate	0.00	0.12	0.90	5.0	773.00	2.61	777.20	18	Cir	0.013	1.48	781.00	MH 27A - CLCB 27A
2	1	40.000	-78.400	Grate	0.00	0.40	0.37	5.0	778.20	2.75	779.30	15	Cir(2b)	0.013	0.50	782.00	CLCB 27A - CLCB 28
3	2	4.000	0.000	DrGrt	2.81	0.23	0.37	5.0	779.30	2.50	779.40	18	Cir	0.012	1.47	781.80	CLCB 28 - MH 30
4	3	41.000	-63.600	DrGrt	0.00	0.20	0.27	5.0	779.40	0.73	779.70	15	Cir	0.012	1.00	782.70	MH 30 - YD 29
5	3	50.000	76.500	DrGrt	0.00	0.03	0.30	5.0	779.40	3.20	781.00	15	Cir	0.012	1.41	784.60	MH 30 - MH 7
6	5	105.000	-68.200	DrGrt	0.00	0.06	0.77	5.0	781.00	8.57	790.00	15	Cir	0.012	0.50	795.80	MH 7 - YD 31
7	6	47.000	9.300	DrGrt	0.00	0.23	0.57	5.0	792.00	10.00	796.70	15	Cir	0.012	0.50	800.70	YD 31 - YD 9
8	7	68.000	8.500	Grate	0.00	0.04	0.85	5.0	796.70	8.97	802.80	15	Cir	0.012	1.48	807.80	YD 9 - CLCB 10
9	8	127.000	-0.200	None	6.32	0.00	0.00	0.0	804.50	7.87	814.50	15	Cir	0.012	1.00	817.00	CLCB 10 - OCS 210
10	5	39.000	-3.500	DrGrt	0.00	0.53	0.25	5.0	781.00	5.13	783.00	12	Cir	0.012	1.00	785.50	MH 7 - YD 6
11	8	90.900	-79.000	DrGrt	0.00	0.08	0.30	5.0	804.50	0.55	805.00	12	Cir	0.012	1.00	809.00	CLCB 10 - YD 61

Project File: Storm 200-05.stm

Number of lines: 11

Date: 4/21/2025

Storm Sewer Tabulation

Station		Len (ft)	Drng Area		Rnoff coeff (C)	Area x C		Tc		Rain (l) (in/hr)	Total flow (cfs)	Cap full (cfs)	Vel (ft/s)	Pipe		Invert Elev		HGL Elev		Grnd / Rim Elev		Line ID
Line	To Line		Incr (ac)	Total (ac)		Incr	Total	Inlet (min)	Syst (min)					Size (in)	Slope (%)	Dn (ft)	Up (ft)	Dn (ft)	Up (ft)	Dn (ft)	Up (ft)	
1	End	161.000	0.12	1.92	0.90	0.11	0.77	5.0	6.5	9.4	16.37	16.96	9.34	18	2.61	773.00	777.20	774.50	778.63	777.70	781.00	MH 27A - CLCB 2
2	1	40.000	0.40	1.80	0.37	0.15	0.66	5.0	6.4	9.4	15.39	21.42	8.61	15(2b)	2.75	778.20	779.30	778.98	780.24	781.00	782.00	CLCB 27A - CLC
3	2	4.000	0.23	1.40	0.37	0.09	0.52	5.0	6.4	9.4	14.00	17.99	9.74	18	2.50	779.30	779.40	780.29	780.78	782.00	781.80	CLCB 28 - MH 30
4	3	41.000	0.20	0.20	0.27	0.05	0.05	5.0	5.0	10.5	0.57	5.98	0.48	15	0.73	779.40	779.70	780.78	780.78	781.80	782.70	MH 30 - YD 29
5	3	50.000	0.03	0.97	0.30	0.01	0.38	5.0	6.2	9.6	9.93	12.51	8.18	15	3.20	779.40	781.00	780.78	782.18	781.80	784.60	MH 30 - MH 7
6	5	105.000	0.06	0.41	0.77	0.05	0.24	5.0	5.9	9.8	8.62	20.48	7.25	15	8.57	781.00	790.00	782.18	791.14	784.60	795.80	MH 7 - YD 31
7	6	47.000	0.23	0.35	0.57	0.13	0.19	5.0	5.9	9.8	8.17	22.12	11.85	15	10.00	792.00	796.70	792.53	797.82	795.80	800.70	YD 31 - YD 9
8	7	68.000	0.04	0.12	0.85	0.03	0.06	5.0	5.7	9.9	6.90	20.95	6.10	15	8.97	796.70	802.80	797.82	803.85	800.70	807.80	YD 9 - CLCB 10
9	8	127.000	0.00	0.00	0.00	0.00	0.00	0.0	0.0	0.0	6.32	19.63	10.09	15	7.87	804.50	814.50	804.99	815.51	807.80	817.00	CLCB 10 - OCS 2
10	5	39.000	0.53	0.53	0.25	0.13	0.13	5.0	5.0	10.5	1.39	8.74	2.66	12	5.13	781.00	783.00	782.18	783.50	784.60	785.50	MH 7 - YD 6
11	8	90.900	0.08	0.08	0.30	0.02	0.02	5.0	5.0	10.5	0.25	2.86	2.20	12	0.55	804.50	805.00	804.70	805.21	807.80	809.00	CLCB 10 - YD 61

Project File: Storm 200-05.stm

Number of lines: 11

Run Date: 4/21/2025

NOTES: Intensity = 48.64 / (Inlet time + 3.70) ^ 0.71; Return period = Yrs. 100 ; c = cir e = ellip b = box

Hydraulic Grade Line Computations

Line	Size (in)	Q (cfs)	Downstream								Len (ft)	Upstream								Check		JL coeff (K)	Minor loss (ft)
			Invert elev (ft)	HGL elev (ft)	Depth (ft)	Area (sqft)	Vel (ft/s)	Vel head (ft)	EGL elev (ft)	Sf (%)		Invert elev (ft)	HGL elev (ft)	Depth (ft)	Area (sqft)	Vel (ft/s)	Vel head (ft)	EGL elev (ft)	Sf (%)	Ave Sf (%)	Enrgy loss (ft)		
1	18	16.37	773.00	774.50	1.50	1.74	9.26	1.33	775.83	2.431	161.000	777.20	778.63	1.43**	1.74	9.42	1.38	780.01	2.107	2.269	n/a	1.48	2.04
2	15(2b)	15.39	778.20	778.98	0.78*	1.62	9.49	0.93	779.91	0.000	40.000	779.30	780.24	0.94**	1.99	7.73	0.93	781.17	0.000	0.000	n/a	0.50	n/a
3	18	14.00	779.30	780.29	0.99*	1.24	11.25	1.05	781.35	0.000	4.000	779.40	780.78	1.38**	1.70	8.23	1.05	781.83	0.000	0.000	n/a	1.47	1.55
4	15	0.57	779.40	780.78	1.25	1.23	0.46	0.00	780.78	0.007	41.000	779.70	780.78	1.08	1.13	0.50	0.00	780.79	0.006	0.006	0.003	1.00	0.00
5	15	9.93	779.40	780.78	1.25	1.20	8.10	1.02	781.80	2.017	50.000	781.00	782.18 j	1.18**	1.20	8.27	1.06	783.25	1.744	1.881	n/a	1.41	n/a
6	15	8.62	781.00	782.18	1.18	1.17	7.17	0.84	783.02	0.000	105.000	790.00	791.14 j	1.14**	1.17	7.33	0.84	791.98	0.000	0.000	n/a	0.50	n/a
7	15	8.17	792.00	792.53	0.53*	0.49	16.66	0.77	793.30	0.000	47.000	796.70	797.82	1.12**	1.16	7.04	0.77	798.59	0.000	0.000	n/a	0.50	0.39
8	15	6.90	796.70	797.82	1.12	1.10	5.94	0.61	798.43	0.000	68.000	802.80	803.85 j	1.05**	1.10	6.25	0.61	804.46	0.000	0.000	n/a	1.48	n/a
9	15	6.32	804.50	804.99	0.49*	0.44	14.25	0.55	805.53	0.000	127.000	814.50	815.51	1.01**	1.07	5.93	0.55	816.06	0.000	0.000	n/a	1.00	0.55
10	12	1.39	781.00	782.18	1.00	0.39	1.77	0.05	782.23	0.130	39.000	783.00	783.50 j	0.50**	0.39	3.55	0.20	783.70	0.525	0.327	n/a	1.00	0.20
11	12	0.25	804.50	804.70	0.20*	0.11	2.24	0.07	804.77	0.000	90.900	805.00	805.21	0.21**	0.12	2.16	0.07	805.28	0.000	0.000	n/a	1.00	n/a

Project File: Storm 200-05.stm

Number of lines: 11

Run Date: 4/21/2025

Notes: * depth assumed; ** Critical depth.; j-Line contains hyd. jump ; c = cir e = ellip b = box

Hydraflow Storm Sewers Extension for Autodesk® Civil 3D® Plan

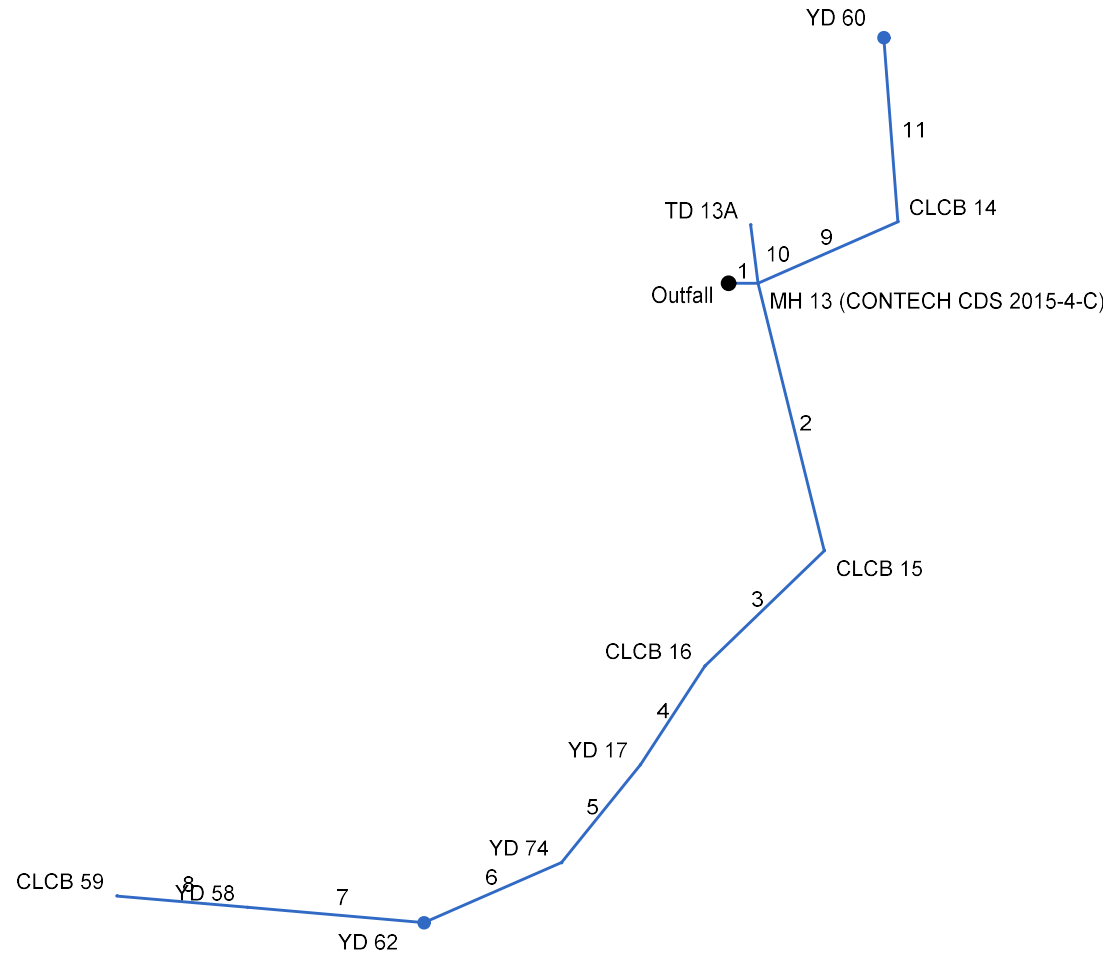

Storm Sewer Inventory Report

Line No.	Alignment				Flow Data				Physical Data								Line ID
	Dnstr Line No.	Line Length (ft)	Defl angle (deg)	Junc Type	Known Q (cfs)	Drng Area (ac)	Runoff Coeff (C)	Inlet Time (min)	Invert El Dn (ft)	Line Slope (%)	Invert El Up (ft)	Line Size (in)	Line Shape	N Value (n)	J-Loss Coeff (K)	Inlet/ Rim El (ft)	
1	End	11.0	0.0	MH	0.00	0.00	0.00	0.0	815.00	0.91	815.10	18	Cir	0.012	1.00	819.00	FES 12 - MH 13
2	1	103.0	76.1	Grate	0.00	0.12	0.72	5.0	815.80	9.90	826.00	12	Cir	0.012	1.33	829.00	MH 13 - CLCB 15
3	2	62.0	59.8	Grate	2.31	0.17	0.61	5.0	828.30	1.77	829.40	12	Cir	0.012	0.50	831.70	CLCB 15 - CLCB 16
4	3	44.0	-12.8	DrGrt	0.00	0.09	0.50	5.0	829.40	2.05	830.30	12	Cir	0.012	0.50	833.70	CLCB 16 - YD 17
5	4	47.0	5.7	DrGrt	0.00	0.05	0.61	5.0	830.30	5.11	832.70	12	Cir	0.012	0.78	845.00	YD 17 - YD 74
6	5	56.0	27.5	DrGrt	0.00	0.00	0.00	0.0	832.70	9.82	838.20	12	Cir	0.012	0.80	844.25	YD 74 - YD 58
7	6	66.0	28.7	DrGrt	0.00	0.01	0.58	5.0	838.20	0.61	838.60	12	Cir	0.012	0.50	843.50	YD 74 - YD 58(2)
8	7	49.0	0.0	Grate	1.14	0.15	0.76	5.0	838.60	0.61	838.90	12	Cir	0.012	1.00	841.90	YD 58 - CLCB 59
9	1	57.0	-23.8	Grate	0.00	0.17	0.66	5.0	815.50	2.63	817.00	12	Cir	0.012	1.43	820.40	MH 13 - CLCB 14
10	1	22.0	-97.2	DrGrt	0.00	0.09	0.84	5.0	815.10	1.14	815.35	8	Cir	0.012	1.00	818.00	MH 13 - TD 13A
11	9	69.0	-70.5	DrGrt	0.00	0.03	0.64	5.0	817.00	0.72	817.50	12	Cir	0.012	1.00	820.00	CLCB 14 - YD 60

Project File: Storm 210-05.stm

Number of lines: 11

Date: 4/17/2025

Storm Sewer Tabulation

Station		Len (ft)	Drng Area		Rnoff coeff (C)	Area x C		Tc		Rain (l) (in/hr)	Total flow (cfs)	Cap full (cfs)	Vel (ft/s)	Pipe		Invert Elev		HGL Elev		Grnd / Rim Elev		Line ID
Line	To Line		Incr (ac)	Total (ac)		Incr	Total	Inlet (min)	Syst (min)					Size (in)	Slope (%)	Dn (ft)	Up (ft)	Dn (ft)	Up (ft)	Dn (ft)	Up (ft)	
1	End	11.0	0.00	0.88	0.00	0.00	0.59	0.0	6.4	6.3	7.15	10.85	5.11	18	0.91	815.00	815.10	816.20	816.13	817.36	819.00	FES 12 - MH 13
2	1	103.0	0.12	0.59	0.72	0.09	0.39	5.0	6.3	6.3	5.89	12.14	11.48	12	9.90	815.80	826.00	816.29	826.95	819.00	829.00	MH 13 - CLCB 15
3	2	62.0	0.17	0.47	0.61	0.10	0.30	5.0	6.1	6.4	5.36	5.14	7.23	12	1.77	828.30	829.40	829.16	830.33	829.00	831.70	CLCB 15 - CLCB
4	3	44.0	0.09	0.30	0.50	0.05	0.20	5.0	5.9	6.5	2.40	5.52	3.75	12	2.05	829.40	830.30	830.33	830.96	831.70	833.70	CLCB 16 - YD 17
5	4	47.0	0.05	0.21	0.61	0.03	0.15	5.0	5.7	6.6	2.13	8.72	3.99	12	5.11	830.30	832.70	830.96	833.32	833.70	845.00	YD 17 - YD 74
6	5	56.0	0.00	0.16	0.00	0.00	0.12	0.0	5.5	6.7	1.94	12.09	3.89	12	9.82	832.70	838.20	833.32	838.79	845.00	844.25	YD 74 - YD 58
7	6	66.0	0.01	0.16	0.58	0.01	0.12	5.0	5.2	6.8	1.96	3.00	4.02	12	0.61	838.20	838.60	838.79	839.20	844.25	843.50	YD 74 - YD 58(2)
8	7	49.0	0.15	0.15	0.76	0.11	0.11	5.0	5.0	6.9	1.93	3.02	3.97	12	0.61	838.60	838.90	839.20	839.49	843.50	841.90	YD 58 - CLCB 59
9	1	57.0	0.17	0.20	0.66	0.11	0.13	5.0	6.0	6.4	0.85	6.26	2.32	12	2.63	815.50	817.00	816.13	817.38	819.00	820.40	MH 13 - CLCB 14
10	1	22.0	0.09	0.09	0.84	0.08	0.08	5.0	5.0	6.9	0.53	1.39	1.50	8	1.14	815.10	815.35	816.13	816.17	819.00	818.00	MH 13 - TD 13A
11	9	69.0	0.03	0.03	0.64	0.02	0.02	5.0	5.0	6.9	0.13	3.28	1.15	12	0.72	817.00	817.50	817.38	817.65	820.40	820.00	CLCB 14 - YD 60

Project File: Storm 210-05.stm

Number of lines: 11

Run Date: 4/17/2025

NOTES: Intensity = 32.58 / (Inlet time + 3.80) ^ 0.71; Return period = Yrs. 10 ; c = cir e = ellip b = box

Hydraulic Grade Line Computations

Line	Size (in)	Q (cfs)	Downstream								Len (ft)	Upstream								Check		JL coeff (K)	Minor loss (ft)
			Invert elev (ft)	HGL elev (ft)	Depth (ft)	Area (sqft)	Vel (ft/s)	Vel head (ft)	EGL elev (ft)	Sf (%)		Invert elev (ft)	HGL elev (ft)	Depth (ft)	Area (sqft)	Vel (ft/s)	Vel head (ft)	EGL elev (ft)	Sf (%)	Ave Sf (%)	Enrgy loss (ft)		
1	18	7.15	815.00	816.20	1.20	1.30	4.72	0.47	816.67	0.000	11.0	815.10	816.13	1.03**	1.30	5.50	0.47	816.61	0.000	0.000	n/a	1.00	0.47
2	12	5.89	815.80	816.29	0.49*	0.38	15.34	0.90	817.20	0.000	103.0	826.00	826.95	0.95**	0.77	7.63	0.90	827.86	0.000	0.000	n/a	1.33	n/a
3	12	5.36	828.30	829.16	0.86*	0.72	7.43	0.77	829.93	0.000	62.0	829.40	830.33	0.93**	0.76	7.02	0.77	831.10	0.000	0.000	n/a	0.50	n/a
4	12	2.40	829.40	830.33	0.93	0.55	3.15	0.29	830.63	0.000	44.0	830.30	830.96 j	0.66**	0.55	4.35	0.29	831.26	0.000	0.000	n/a	0.50	n/a
5	12	2.13	830.30	830.96	0.66	0.51	3.85	0.27	831.23	0.000	47.0	832.70	833.32 j	0.62**	0.51	4.14	0.27	833.59	0.000	0.000	n/a	0.78	n/a
6	12	1.94	832.70	833.32	0.62	0.49	3.78	0.25	833.57	0.000	56.0	838.20	838.79 j	0.59**	0.49	4.00	0.25	839.04	0.000	0.000	n/a	0.80	n/a
7	12	1.96	838.20	838.79	0.59	0.49	4.03	0.25	839.04	0.000	66.0	838.60	839.20	0.60**	0.49	4.01	0.25	839.45	0.000	0.000	n/a	0.50	0.12
8	12	1.93	838.60	839.20	0.60	0.48	3.95	0.25	839.44	0.000	49.0	838.90	839.49 j	0.59**	0.48	3.99	0.25	839.74	0.000	0.000	n/a	1.00	n/a
9	12	0.85	815.50	816.13	0.63	0.28	1.61	0.14	816.28	0.000	57.0	817.00	817.38 j	0.38**	0.28	3.04	0.14	817.53	0.000	0.000	n/a	1.43	n/a
10	8	0.53	815.10	816.13	0.67	0.35	1.50	0.04	816.17	0.161	22.0	815.35	816.17	0.67	0.35	1.50	0.04	816.21	0.161	0.161	0.035	1.00	0.04
11	12	0.13	817.00	817.38	0.38	0.07	0.48	0.05	817.44	0.000	69.0	817.50	817.65 j	0.15**	0.07	1.82	0.05	817.70	0.000	0.000	n/a	1.00	0.05

Project File: Storm 210-05.stm

Number of lines: 11

Run Date: 4/17/2025

Notes: * depth assumed; ** Critical depth.; j-Line contains hyd. jump ; c = cir e = ellip b = box

Hydraflow Storm Sewers Extension for Autodesk® Civil 3D® Plan

YD 72

1

● Outfall

Storm Sewer Inventory Report

Line No.	Alignment				Flow Data				Physical Data								Line ID
	Dnstr Line No.	Line Length (ft)	Defl angle (deg)	Junc Type	Known Q (cfs)	Drng Area (ac)	Runoff Coeff (C)	Inlet Time (min)	Invert El Dn (ft)	Line Slope (%)	Invert El Up (ft)	Line Size (in)	Line Shape	N Value (n)	J-Loss Coeff (K)	Inlet/ Rim El (ft)	
1	End	75.0	-109.4	None	0.25	0.53	0.51	5.0	815.00	0.67	815.50	12	Cir	0.012	1.00	817.50	FES 76 - YD 72

Project File: Storm 210-05-2.stm

Number of lines: 1

Date: 4/17/2025

Storm Sewer Tabulation

Station		Len (ft)	Drng Area		Rnoff coeff (C)	Area x C		Tc		Rain (l) (in/hr)	Total flow (cfs)	Cap full (cfs)	Vel (ft/s)	Pipe		Invert Elev		HGL Elev		Grnd / Rim Elev		Line ID
Line	To Line		Incr (ac)	Total (ac)		Incr	Total	Inlet (min)	Syst (min)					Size (in)	Slope (%)	Dn (ft)	Up (ft)	Dn (ft)	Up (ft)	Dn (ft)	Up (ft)	
1	End	75.0	0.53	0.53	0.51	0.27	0.27	5.0	5.0	7.2	2.21	3.15	2.86	12	0.67	815.00	815.50	816.20	816.42	816.00	817.50	FES 76 - YD 72

Project File: Storm 210-05-2.stm

Number of lines: 1

Run Date: 4/17/2025

NOTES: Intensity = $88.24 / (\text{Inlet time} + 15.50)^{0.83}$; Return period = Yrs. 10 ; c = cir e = ellip b = box

Hydraulic Grade Line Computations

Line	Size (in)	Q (cfs)	Downstream								Len (ft)	Upstream								Check		JL coeff (K)	Minor loss (ft)
			Invert elev (ft)	HGL elev (ft)	Depth (ft)	Area (sqft)	Vel (ft/s)	Vel head (ft)	EGL elev (ft)	Sf (%)		Invert elev (ft)	HGL elev (ft)	Depth (ft)	Area (sqft)	Vel (ft/s)	Vel head (ft)	EGL elev (ft)	Sf (%)	Ave Sf (%)	Enrgy loss (ft)		
1	12	2.21	815.00	816.20	1.00	0.79	2.81	0.12	816.32	0.327	75.0	815.50	816.42	0.92	0.76	2.92	0.13	816.55	0.284	0.306	0.229	1.00	0.13

Project File: Storm 210-05-2.stm

Number of lines: 1

Run Date: 4/17/2025

; c = cir e = ellip b = box

Hydraflow Storm Sewers Extension for Autodesk® Civil 3D® Plan

OCS 220 (ID 22)

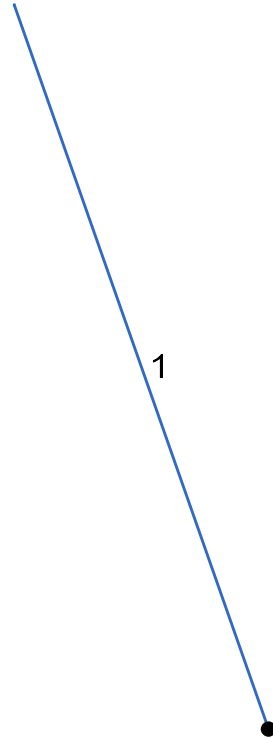

1

● Outfall

Storm Sewer Inventory Report

Line No.	Alignment				Flow Data				Physical Data								Line ID
	Dnstr Line No.	Line Length (ft)	Defl angle (deg)	Junc Type	Known Q (cfs)	Drng Area (ac)	Runoff Coeff (C)	Inlet Time (min)	Invert El Dn (ft)	Line Slope (%)	Invert El Up (ft)	Line Size (in)	Line Shape	N Value (n)	J-Loss Coeff (K)	Inlet/ Rim El (ft)	
1	End	45.0	-109.4	None	4.73	0.00	0.00	0.0	800.00	1.11	800.50	15	Cir	0.012	1.00	803.53	FES 21 - OCS 220

Project File: Outlet 220-04.stm

Number of lines: 1

Date: 12/9/2024

Storm Sewer Tabulation

Station		Len (ft)	Drng Area		Rnoff coeff (C)	Area x C		Tc		Rain (l) (in/hr)	Total flow (cfs)	Cap full (cfs)	Vel (ft/s)	Pipe		Invert Elev		HGL Elev		Grnd / Rim Elev		Line ID
Line	To Line		Incr (ac)	Total (ac)		Incr	Total	Inlet (min)	Syst (min)					Size (in)	Slope (%)	Dn (ft)	Up (ft)	Dn (ft)	Up (ft)	Dn (ft)	Up (ft)	
1	End	45.0	0.00	0.00	0.00	0.00	0.00	0.0	0.0	0.0	4.73	7.37	4.49	15	1.11	800.00	800.50	801.25	801.38	801.36	803.53	FES 21 - OCS 22

Project File: Outlet 220-04.stm

Number of lines: 1

Run Date: 12/9/2024

NOTES: Intensity = 48.64 / (Inlet time + 3.70) ^ 0.71; Return period = Yrs. 100 ; c = cir e = ellip b = box

Hydraulic Grade Line Computations

Line	Size (in)	Q (cfs)	Downstream								Len (ft)	Upstream								Check		JL coeff (K)	Minor loss (ft)
			Invert elev (ft)	HGL elev (ft)	Depth (ft)	Area (sqft)	Vel (ft/s)	Vel head (ft)	EGL elev (ft)	Sf (%)		Invert elev (ft)	HGL elev (ft)	Depth (ft)	Area (sqft)	Vel (ft/s)	Vel head (ft)	EGL elev (ft)	Sf (%)	Ave Sf (%)	Enrgy loss (ft)		
1	15	4.73	800.00	801.25	1.25	0.92	3.86	0.23	801.48	0.457	45.0	800.50	801.38 j	0.88**	0.92	5.12	0.41	801.79	0.641	0.549	n/a	1.00	0.41

Project File: Outlet 220-04.stm

Number of lines: 1

Run Date: 12/9/2024

Notes: ; ** Critical depth.; j-Line contains hyd. jump ; c = cir e = ellip b = box

Outlet Protection Calculations

Project: Wake Robin Inn
 Location: Salisbury, CT
 Outlet I.D. **FES 12**

By: MCB
 Checked: TDR

Date: Rev. 4/21/25
 Date: 4/21/2025

*Based on Connecticut DOT Drainage Manual, Section 11.13

Description:

FES 12

Design Criteria (10-yr Storm Event):

Q (cfs) = 7.15	R _p (ft)=	1.5
D (in) = 18	S _p (ft) =	1.5
V (fps) = 5.11	Tw (ft)=	1.2

Q= Flow rate at discharge point in cubic feet per second (cfs)
 D= Outlet pipe diameter (in)
 V= Flow velocity at discharge point (ft/s)
 R_p= Maximum inside pipe rise (ft)
 S_p= inside diametere for circular sections of maximum inside pipe span for non-circular sections (ft)
 T_w= Tailwater depth (ft)

Based on **Table 11.13.1**, A *Preformed Scour Hole* is used *One Half Pipe Rise Depression (Type I)*

Rip Rap Stone Size:

<u>D₅₀ Computed (ft)</u>	<u>Rip Rap Specification</u>	<u>D₅₀ Stone Size Required</u>
0.083	Modified	5 inches

Preformed Scour Hole Dimensions:

F = 0.5(R _p)	=	0.75 ft
C = 3.0(S _p)+6.0(F)	=	9ft
B = 2.0(S _p)+6.0(F)	=	7.5ft
d (Depth of Stone)	=	12 inches

Outlet Protection Calculations

Project: Wake Robin Inn
Location: Salisbury, CT
Outlet I.D.: **FES 23**

By: MCB
Checked: TDR

Date: Rev. 11/4/24
Date: # 11/04/24

*Based on Connecticut DOT Drainage Manual, Section 11.13

Description:

FES 23

Design Criteria (10-yr Storm Event):

Q (cfs) = 0.66 R_p (ft)= 0.67
D (in) = 8 S_p (ft) = 0.67
V (fps) = 4.7 Tw (ft)= 0.23

Q= Flow rate at discharge point in cubic feet per second (cfs)

D= Outlet pipe diameter (in)

V= Flow velocity at discharge point (ft/s)

R_p= Maximum inside pipe rise (ft)

S_p= inside diametere for circular sections of maximum inside pipe span for non-circular sections (ft)

T_w= Tailwater depth (ft)

Based on **Table 11-12.1** use Type 'A' ----> TW < 0.5 R_p

Rip Rap Stone Size:

<u>Velocity</u>	<u>Rip Rap Specification</u>	<u>D₅₀ Stone Size</u>
0-8 fps	Modified	5 inches

Preformed Scour Hole Dimensions:

F(ft)=0.5(R_p) = n/a
C(ft)=3.0(S_p)+6.0(F) = n/a
B(ft)=2.0(S_p)+6.0(F) = n/a

Rip Rap Splash Pad Dimensions:

L_a = 10 ft
W1 = 3.0(S_p) min. = 2 ft
W2 = 3.0(S_p)+0.7(L_a) min. = 9 ft
d (Depth of Stone) = 12 inches

Outlet Protection Calculations

Project: Wake Robin Inn
Location: Salisbury, CT
Outlet I.D.: **FES 32**

By: MCB
Checked: TDR

Date: 06/26/25
Date: # 06/26/25

*Based on Connecticut DOT Drainage Manual, Section 11.13

Description:

FES 32

Design Criteria (10-yr Storm Event):

Q (cfs) = 2.81 R_p (ft) = 1.50
D (in) = 18 S_p (ft) = 1.50
V (fps) = 8.28 T_w (ft) = 0.37

Q= Flow rate at discharge point in cubic feet per second (cfs)

D= Outlet pipe diameter (in)

V= Flow velocity at discharge point (ft/s)

R_p = Maximum inside pipe rise (ft)

S_p = inside diameters for circular sections of maximum inside pipe span for non-circular sections (ft)

T_w = Tailwater depth (ft)

Based on **Table 11-12.1** use Type 'A' ----> $TW < 0.5 R_p$

Rip Rap Stone Size:

<u>Velocity</u>	<u>Rip Rap Specification</u>	<u>D₅₀ Stone Size</u>
8-10 fps	Intermediate	8 inches

Preformed Scour Hole Dimensions:

F (ft)= $0.5(R_p)$ = n/a
 C (ft)= $3.0(S_p)+6.0(F)$ = n/a
 B (ft)= $2.0(S_p)+6.0(F)$ = n/a

Rip Rap Splash Pad Dimensions:

L_a = 12 ft
 $W1 = 3.0(S_p)$ min. = 5 ft
 $W2 = 3.0(S_p)+0.7(L_a)$ min. = 13 ft
d (Depth of Stone) = 18 inches

Outlet Protection Calculations

Project: Wake Robin Inn
Location: Salisbury, CT
Outlet I.D.: **FES 76**

By: MCB
Checked: TDR

Date: 06/26/25
Date: # 06/26/25

*Based on Connecticut DOT Drainage Manual, Section 11.13

Description:

FES 76

Design Criteria (10-yr Storm Event):

Q (cfs) = 2.21 R_p (ft) = 1.00
D (in) = 12 S_p (ft) = 1.00
V (fps) = 2.86 T_w (ft) = 1.2

Q= Flow rate at discharge point in cubic feet per second (cfs)

D= Outlet pipe diameter (in)

V= Flow velocity at discharge point (ft/s)

R_p = Maximum inside pipe rise (ft)

S_p = inside diameters for circular sections of maximum inside pipe span for non-circular sections (ft)

T_w = Tailwater depth (ft)

Based on **Table 11-13.1** use Type 'B' ----> $TW \geq 0.5 R_p$

Rip Rap Stone Size:

<u>Velocity</u>	<u>Rip Rap Specification</u>	<u>D_{50} Stone Size</u>
0-8 fps	Modified	5 inches

Preformed Scour Hole Dimensions:

F (ft) = $0.5(R_p)$ = n/a
 C (ft) = $3.0(S_p) + 6.0(F)$ = n/a
 B (ft) = $2.0(S_p) + 6.0(F)$ = n/a

Rip Rap Splash Pad Dimensions:

L_a = 10 ft
 $W1 = 3.0(S_p)$ min. = 3 ft
 $W2 = 3.0(S_p) + 0.4(L_a)$ min. = 7 ft
d (Depth of Stone) = 12 inches

Level Spreader Design

Level Spreader 220

Broad Crest Elevation (ft)	801.00
Length (ft)	30
Discharge Coefficient	3.2
Elevation Increment	0.05
Q-100 year (cfs)	4.73 (DET 220 Discharge)

Elevation (Feet)	Weir Discharge (cfs)	Area (sf)	Velocity (fps)
801.00	0.00	0.00	0.00
801.05	1.07	1.50	0.72
801.10	3.04	3.00	1.01
801.13	4.73	4.03	1.17
801.15	5.58	4.50	1.24
801.20	8.59	6.00	1.43
801.25	12.00	7.50	1.60
801.30	15.77	9.00	1.75
801.35	19.88	10.50	1.89
801.40	24.29	12.00	2.02
801.45	28.98	13.50	2.15
801.50	33.94	15.00	2.26

Channel Report

Bridge

Rectangular

Bottom Width (ft) = 8.00
Total Depth (ft) = 1.25

Invert Elev (ft) = 826.90
Slope (%) = 2.30
N-Value = 0.024

Calculations

Compute by: Known Q
Known Q (cfs) = 11.60

Highlighted

Depth (ft) = 0.35
Q (cfs) = 11.60
Area (sqft) = 2.80
Velocity (ft/s) = 4.23
Wetted Perim (ft) = 8.70
Crit Depth, Yc (ft) = 0.41
Top Width (ft) = 8.00
EGL (ft) = 0.63

Water Surface Elevation = 827.25
Low Chord of Bridge = 828.25
Top of Bridge = 829.5

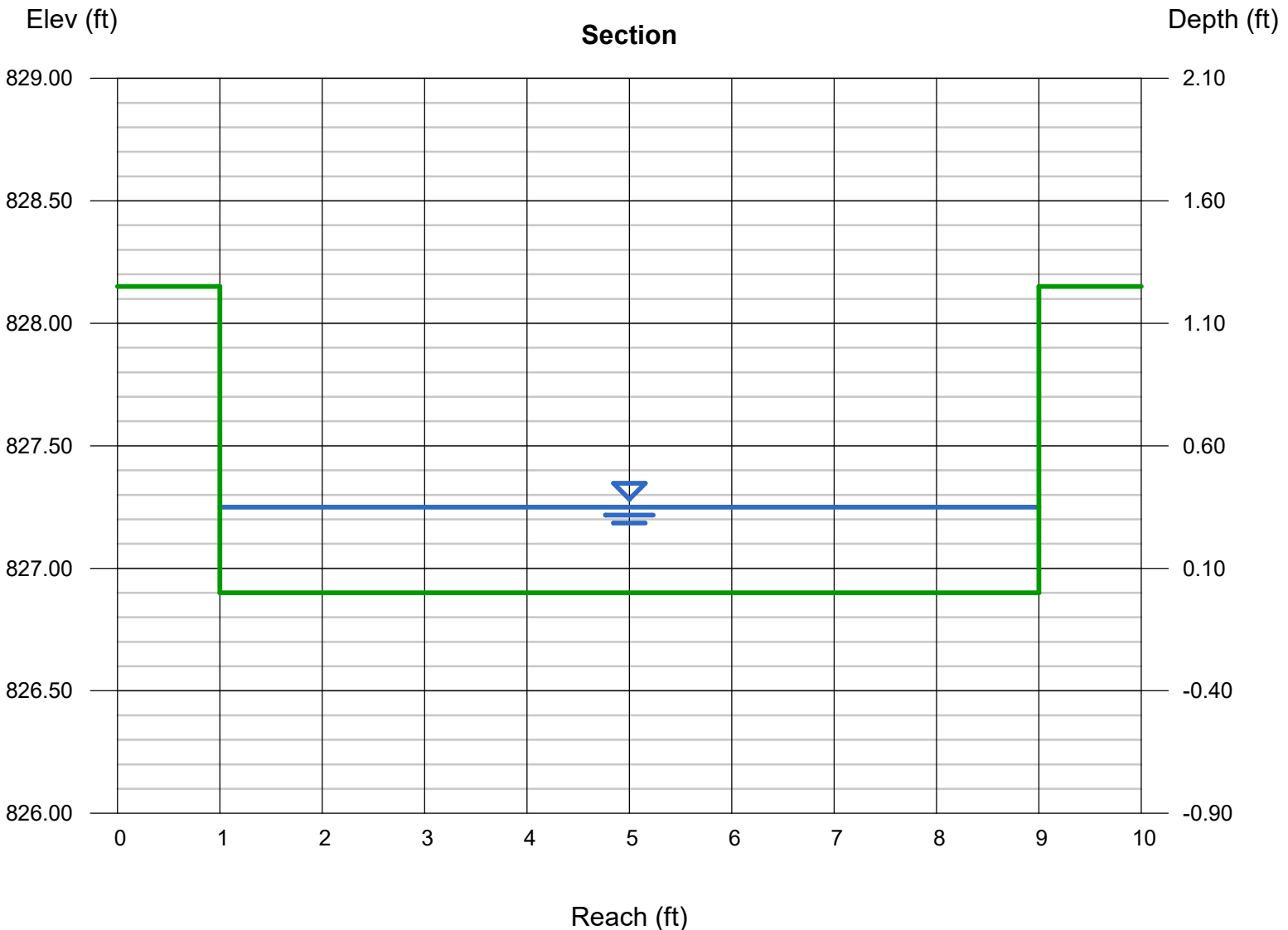

Time of Concentration (T_c) or Travel Time (T_t) Worksheet

Project: Wake Robin Inn Redevelopment
 Location: Salisbury, CT
 Circle one: Present Developed
 Circle one: T_c T_t

By: MCB Date: Rev. 11/04/24
 Checked: TDR Date: 11/04/24
 Watershed: Bridge
 Subwatershed: _____

Sheet flow (applicable to T_c only)

1. Surface description (Table 3-1)
2. Manning's roughness coeff. for sheet flow, n (Table 3-1)
3. Flow Length, L (< 300ft)
4. Two-year 24-hr rainfall, P_2
5. Land slope, s
6. $T_t = \frac{0.007 (nL)^{0.8}}{P_2^{0.5} (s^{0.4})}$

Segment ID	A-B				
	WOODS				
	0.400				
	ft. 100.0				
	in. 3.08				
	ft./ft. 0.035				
	hr. 0.292	=			0.292

Shallow concentrated flow (assume hyd. radius = depth of flow)

7. Surface description
8. Manning's roughness coeff., n
9. Paved or unpaved
10. Depth of flow, d (default values: d=.4 unpaved, d=.2 paved) ft.
11. Flow Length, L
12. Watercourse slope, s
13. Average velocity, $V = \frac{1.49}{n} (d^{2/3})(s^{1/2})$
14. $T_t = \frac{L}{3600 * V}$

Segment ID	B-C				
	WOODS				
	0.100				
	UNPVD				
	ft. 0.40				
	ft. 1176.0				
	ft./ft. 0.013				
	fps. 0.92				
	hr. 0.354				= 0.354

Channel flow

15. Channel Bottom width, b
16. Horizontal side slope component, z (z horiz:1 vert)
17. Depth of flow, d
18. Cross sectional flow area, A (assume trapazoidal) ft.²
19. Wetted perimeter, P_w
20. Hydraulic Radius, $R = \frac{A}{P_w}$
21. Channel slope, s
22. Manning's roughness coeff., n
23. $V = \frac{1.49}{n} (R^{2/3})(s^{1/2})$
24. Flow length, L
25. $T_t = \frac{L}{3600 * V}$
26. Watershed or subarea T_c or T_t (add T_t in steps 6, 14 & 25)

Segment ID	C-D				
	ft. 6.00				
	ft. 4.00				
	ft. 1.00				
	ft. ² 10.00				
	ft. 14.25				
	ft. 0.70				
	ft./ft. 0.057				
	0.024				
	fps. 11.71				
	ft. 6.0				
	hr. 0.000	+			= 0.000
					0.646
					hr.

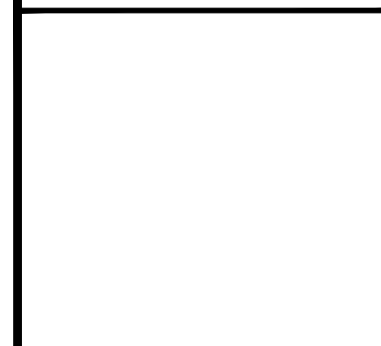
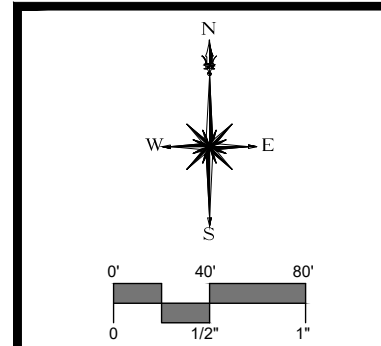

DESCRIPTION	DATE	BY
ENGINEERING COMMENTS	07/29/2025	MCB

DRAINAGE AREA MAP - STORM DRAINAGE SYSTEM
WAKE ROBIN INN REDEVELOPMENT
 104 & 106 SHARON ROAD
 SALISBURY, CONNECTICUT

DESIGNED	MCB
DRAWN	MCB
CHECKED	TDR
SCALE: 1"=80'	
DATE: APRIL 29, 2025	
PROJECT NO: 22100.00001	
SHEET NO: 1 OF 1	
CB	



Appendix E

Water Quality Computations

Wake Robin Inn Redevelopment

104 & 106 Sharon Road, Salisbury, Connecticut

Drainage Report

Prepared for:
Aradev LLC
352 Atlantic Avenue, Unit 2
Brooklyn, NY 11217

SLR Project No.: 141.22100.00001

April 25, 2025

Revised July 28, 2025



STORMWATER QUALITY CALCULATIONS
Water Quality Volume (WQV)

Basin ID	Total Area (ac.)	Impervious Area (ac.)	Percent Impervious	Volumetric Runoff Coeff., R	WQV (ac-ft)	Total Volume Required (ac-ft)	Total Volume Provided¹⁻ (ac-ft)
140	0.33	0.10	30%	0.32	0.012	0.012	0.022
210	2.84	1.42	50%	0.50	0.154	0.154	0.171
220	0.76	0.45	59%	0.58	0.048	0.048	0.050

1.- Volume provided below low-flow orifice

$$\mathbf{WQV} = \frac{(1.3 \text{ inches}) \times A \times R}{12}$$

Where:

- WQV = Water Quality Volume in acre-feet
- A = Contributing Area in acres
- R = $0.05 + 0.009 (I)$
- I = Site Imperviousness as percent

STORMWATER QUALITY CALCULATIONS
Water Quality Volume (WQV)

DET 210

Elevation (ft)	Surface Area (ft ²)	Volume (ft ³)	Volume (ac-ft)	Cumulative Volume (ac-ft)
815.0	7,672	0.0	0.000	0.000
815.9	8,852	7,435.8	0.171	0.171

DET 220

Elevation (ft)	Surface Area (ft ²)	Volume (ft ³)	Volume (ac-ft)	Cumulative Volume (ac-ft)
801.0	1,433	0.0	0.000	0.000
802.0	2,039	1,736.0	0.040	0.040
802.2	2,165	420.4	0.010	0.050

WQ 140

Elevation (ft)	Surface Area (ft ²)	Volume (ft ³)	Volume (ac-ft)	Cumulative Volume (ac-ft)
837.5	801	0.0	0.000	0.000
838.0	964	441.3	0.010	0.010
838.5	1,143	526.8	0.012	0.022

Drawdown Computations

Basin ID	Bottom Area (sf)	Volume to be Infiltrated (cf)	Infil. Rate (in/hr)	Drawdown Time (hr)
DET 210	7672	7438	3.0	3.88
DET 220	1433	2156	1.58	11.43
WQ 140	801	968	0.46	31.53

		SLR Consulting			Project	22100.00001	
		COMPUTATION SHEET - WATER QUALITY FLOW (WQF)			Made By:	MCB	
Subject:	Wake Robin Inn				Date:	Rev. 4/21/25	
					Chkd by:	TDR	
					Date:	4/21/2025	
CDS Unit - MH 13							
Contributing Basins		Imperv. Area (acres)	Total Area (acres)				
Total		1.11	1.55				
Table 4.1: $WQV = (P)(R_v)(A)/12 =$				0.117	acre-feet		
Where:							
I = % of Impervious Cover =				72%			
$R_v =$ volumetric runoff coeff. $0.05 + 0.009(I) =$				0.695			
P = design precipitation (1.3" for water quality storm) =				1.3	inch		
A = site area (acres) =				1.55	acres =	0.0024	miles ²
$Q =$ runoff depth (in watershed inches) = $[WQV(\text{acrefeet})][12(\text{inches/foot})]/\text{drainage area (acres)}$							
				Q =	0.903		
CN = $1000 / [10 + 5P + 10Q - 10(Q^2 + 1.25QP)^{0.5}] =$				96			
Where:							
Q = runoff depth (in watershed inches)							
				$t_c =$	0.1	hours	
Type III Rainfall Distribution:							
From Table 4-1, $l_a =$		0.083	$l_a/P =$		0.0638		
(TR-55)							
From Exhibit 4-III, $q_u =$		675	csm/in.				
(TR-55)							
WQF = $(q_u)(A)(Q) =$		1.48	cfs		CDS 2020-5-C Flow = 2.20 -> OK		

SLR Consulting		Project	22100.00001
COMPUTATION SHEET - WATER QUALITY FLOW (WQF)		Made By:	MCB
Subject:	Wake Robin Inn	Date:	7/24/2025
		Chkd by:	TDR
		Date:	7/24/2025
<u>CDS Unit - MH 30</u>			
Contributing Basins		Imperv. Area (acres)	Total Area (acres)
Total		0.57	2.71
Table 4.1: $WQV = (P)(R_v)(A)/12 =$			0.070 acre-feet
Where:			
I = % of Impervious Cover =			21%
$R_v =$ volumetric runoff coeff. $0.05 + 0.009(I) =$			0.239
P = design precipitation (1.3" for water quality storm) =			1.3 inch
A = site area (acres) =			2.71 acres = 0.0042 miles ²
Q = runoff depth (in watershed inches) = $[WQV(\text{acrefeet})][12(\text{inches/foot})]/\text{drainage area (acres)}$			
		Q =	0.311
CN = $1000 / [10 + 5P + 10Q - 10(Q^2 + 1.25QP)^{0.5}] =$			84
Where:			
Q = runoff depth (in watershed inches)			
		$t_c =$	0.1 hours
Type III Rainfall Distribution:			
From Table 4-1, $I_a =$		0.083	$I_a/P =$ 0.0638
(TR-55)			
From Exhibit 4-III, $q_u =$		375 csm/in.	
(TR-55)			
WQF = $(q_u)(A)(Q) =$		0.49 cfs	CDS 2015-4-C Flow = 1.40 -> OK



2. Compute the time of concentration (t_c) based on the methods described in Chapter 3 of TR-55. A minimum value of 0.167 hours (10 minutes) should be used. For sheet flow, the flow path should not be longer than 300 feet.
3. Using the computed CN, t_c , and drainage area (A) in acres, compute the peak discharge for the water quality storm (i.e., the water quality flow [WQF]), based on the procedures described in Chapter 4 of TR-55.
 - Read initial abstraction (I_a) from Table 4-1 in Chapter 4 of TR-55 (reproduced below); compute I_a/P

Table 4-1 I_a values for runoff curve numbers

Curve number	I_a (in)	Curve number	I_a (in)	Curve number	I_a (in)	Curve number	I_a (in)
40	3.000	55	1.636	70	0.857	85	0.353
41	2.878	56	1.571	71	0.817	86	0.326
42	2.762	57	1.509	72	0.778	87	0.299
43	2.651	58	1.448	73	0.740	88	0.273
44	2.545	59	1.390	74	0.703	89	0.247
45	2.444	60	1.333	75	0.667	90	0.222
46	2.348	61	1.279	76	0.632	91	0.198
47	2.255	62	1.226	77	0.597	92	0.174
48	2.167	63	1.175	78	0.564	93	0.151
49	2.082	64	1.125	79	0.532	94	0.128
50	2.000	65	1.077	80	0.500	95	0.105
51	1.922	66	1.030	81	0.469	96	0.083
52	1.846	67	0.985	82	0.439	97	0.062
53	1.774	68	0.941	83	0.410	98	0.041
54	1.704	69	0.899	84	0.381		

- Read the unit peak discharge (q_u) from Exhibit 4-III in Chapter 4 of TR-55 (reproduced below) for appropriate t_c

Exhibit 4-III Unit peak discharge (q_u) for NRCS (SCS) type III rainfall distribution

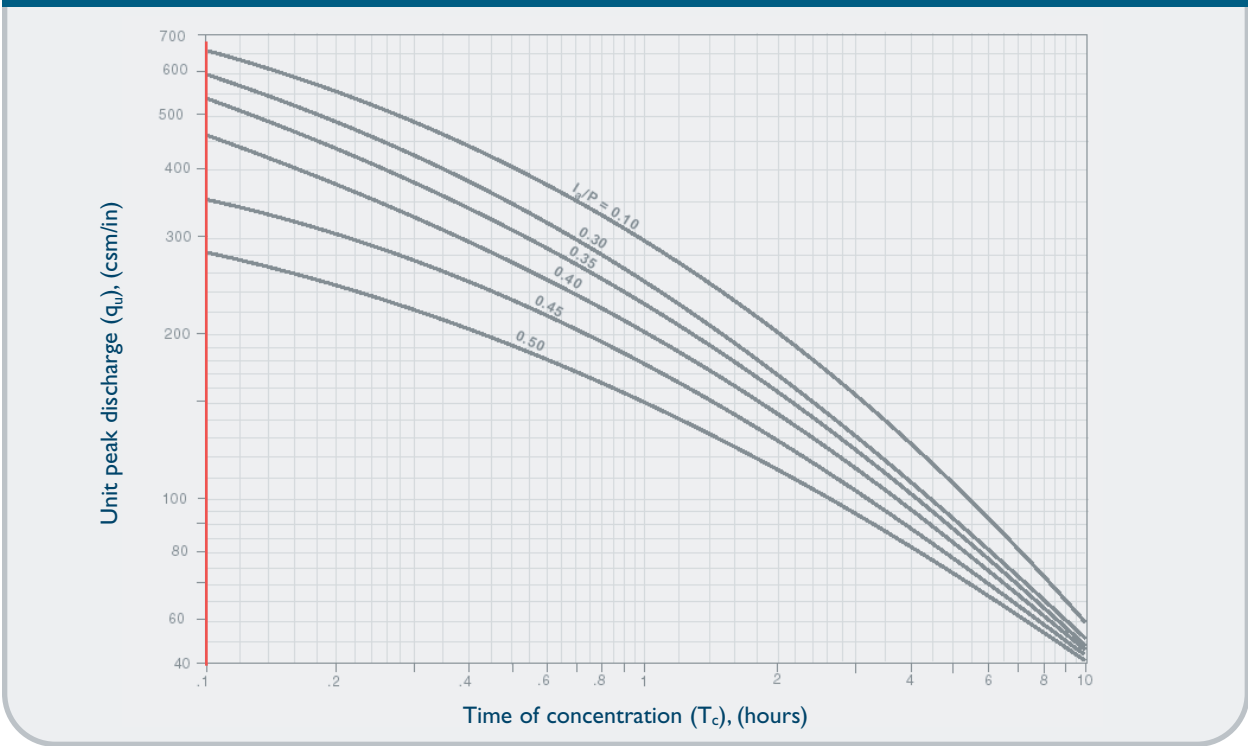



2. Compute the time of concentration (t_c) based on the methods described in Chapter 3 of TR-55. A minimum value of 0.167 hours (10 minutes) should be used. For sheet flow, the flow path should not be longer than 300 feet.
3. Using the computed CN, t_c , and drainage area (A) in acres, compute the peak discharge for the water quality storm (i.e., the water quality flow [WQF]), based on the procedures described in Chapter 4 of TR-55.
 - Read initial abstraction (I_a) from Table 4-1 in Chapter 4 of TR-55 (reproduced below); compute I_a/P

Table 4-1 I_a values for runoff curve numbers

Curve number	I_a (in)	Curve number	I_a (in)	Curve number	I_a (in)	Curve number	I_a (in)
40	3.000	55	1.636	70	0.857	85	0.353
41	2.878	56	1.571	71	0.817	86	0.326
42	2.762	57	1.509	72	0.778	87	0.299
43	2.651	58	1.448	73	0.740	88	0.273
44	2.545	59	1.390	74	0.703	89	0.247
45	2.444	60	1.333	75	0.667	90	0.222
46	2.348	61	1.279	76	0.632	91	0.198
47	2.255	62	1.226	77	0.597	92	0.174
48	2.167	63	1.175	78	0.564	93	0.151
49	2.082	64	1.125	79	0.532	94	0.128
50	2.000	65	1.077	80	0.500	95	0.105
51	1.922	66	1.030	81	0.469	96	0.083
52	1.846	67	0.985	82	0.439	97	0.062
53	1.774	68	0.941	83	0.410	98	0.041
54	1.704	69	0.899	84	0.381		

- Read the unit peak discharge (q_u) from Exhibit 4-III in Chapter 4 of TR-55 (reproduced below) for appropriate t_c

Exhibit 4-III Unit peak discharge (q_u) for NRCS (SCS) type III rainfall distribution

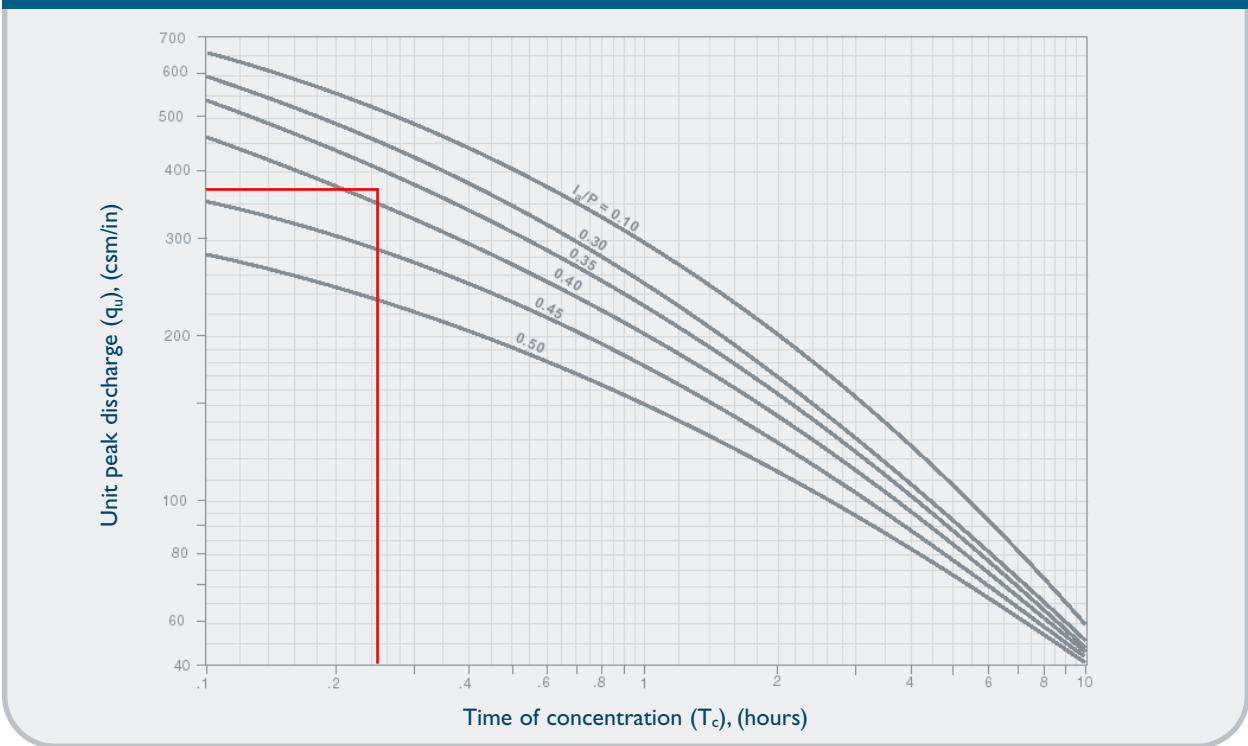

Product Flow Rates

CASCADE

Model	Treatment Rate (cfs)	Sediment Capacity ¹ (CF)
CS-4	2.00	19
CS-5	3.50	29
CS-6	5.60	42
CS-8	12.00	75
CS-10	18.00	118

CDS

Model	Treatment Rate ² (cfs)	Sediment Capacity ¹ (CF)
1515-3	1.00	14
2015-4	1.40	25
2015-5	1.40	39
2015-6	1.40	57
2020-5	2.20	39
2020-6	2.20	57
2025-5	3.20	39
2025-6	3.20	57
3020-6	3.90	57
3025-6	5.00	57
3030-6	5.70	57
3035-6	6.50	57
4030-8	7.50	151
4040-8	9.50	151

VORTECHS

Model	Treatment Rate (cfs)	Sediment Capacity ³ (CF)
1000	1.60	16
2000	2.80	32
3000	4.50	49
4000	6.00	65
5000	8.50	86
7000	11.00	108
9000	14.00	130
11000	17.5	151
16000	25	192

STORMCEPTOR STC

Model	Treatment Rate (cfs)	Sediment Capacity ¹ (CF)
STC 450i	0.40	46
STC 900	0.89	89
STC 2400	1.58	205
STC 4800	2.47	543
STC 7200	3.56	839
STC 11000	4.94	1086
STC 16000	7.12	1677

1 Additional sediment storage capacity available – Check with your local representative for information.

2 Treatment Capacity is based on laboratory testing using OK-110 (average D50 particle size of approximately 100 microns) and a 2400 micron screen.

3 Maintenance recommended when sediment depth has accumulated to within 12-18 inches of the dry weather water surface elevation.



NOTHING IN THIS CATALOG SHOULD BE CONSTRUED AS A WARRANTY. APPLICATIONS SUGGESTED HEREIN ARE DESCRIBED ONLY TO HELP READERS MAKE THEIR OWN EVALUATIONS AND DECISIONS, AND ARE NEITHER GUARANTEES NOR WARRANTIES OF SUITABILITY FOR ANY APPLICATION. CONTECH MAKES NO WARRANTY WHATSOEVER, EXPRESS OR IMPLIED, RELATED TO THE APPLICATIONS, MATERIALS, COATINGS, OR PRODUCTS DISCUSSED HEREIN. ALL IMPLIED WARRANTIES OF MERCHANTABILITY AND ALL IMPLIED WARRANTIES OF FITNESS FOR ANY PARTICULAR PURPOSE ARE DISCLAIMED BY CONTECH. SEE CONTECH'S CONDITIONS OF SALE (AVAILABLE AT WWW.CONTECHES.COM/COS) FOR MORE INFORMATION.



Get social with us: [f](#) [in](#) [t](#) [v](#)

800-338-1122 | www.ContechES.com

CDS Guide

Operation, Design, Performance and Maintenance



CDS®

Using patented continuous deflective separation technology, the CDS system screens, separates and traps debris, sediment, and oil and grease from stormwater runoff. The indirect screening capability of the system allows for 100% removal of floatables and neutrally buoyant material without blinding. Flow and screening controls physically separate captured solids, and minimize the re-suspension and release of previously trapped pollutants. Inline units can treat up to 6 cfs, and internally bypass flows in excess of 50 cfs (1416 L/s). Available precast or cast-in-place, offline units can treat flows from 1 to 300 cfs (28.3 to 8495 L/s). The pollutant removal capacity of the CDS system has been proven in lab and field testing.

Operation Overview

Stormwater enters the diversion chamber where the diversion weir guides the flow into the unit's separation chamber and pollutants are removed from the flow. All flows up to the system's treatment design capacity enter the separation chamber and are treated.

Swirl concentration and screen deflection force floatables and solids to the center of the separation chamber where 100% of floatables and neutrally buoyant debris larger than the screen apertures are trapped.

Stormwater then moves through the separation screen, under the oil baffle and exits the system. The separation screen remains clog free due to continuous deflection.

During the flow events exceeding the treatment design capacity, the diversion weir bypasses excessive flows around the separation chamber, so captured pollutants are retained in the separation cylinder.

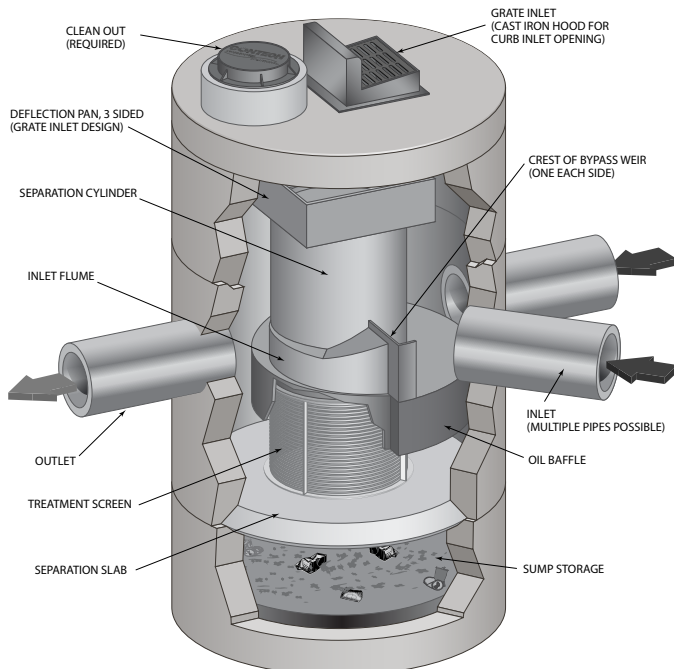

Design Basics

There are three primary methods of sizing a CDS system. The Water Quality Flow Rate Method determines which model size provides the desired removal efficiency at a given flow rate for a defined particle size. The Rational Rainfall Method™ or the Probabilistic Method is used when a specific removal efficiency of the net annual sediment load is required.

Typically in the United States, CDS systems are designed to achieve an 80% annual solids load reduction based on lab generated performance curves for a gradation with an average particle size (d50) of 125 microns (μm). For some regulatory environments, CDS systems can also be designed to achieve an 80% annual solids load reduction based on an average particle size (d50) of 75 microns (μm) or 50 microns (μm).

Water Quality Flow Rate Method

In some cases, regulations require that a specific treatment rate, often referred to as the water quality design flow (WQQ), be treated. This WQQ represents the peak flow rate from either an event with a specific recurrence interval, e.g. the six-month storm, or a water quality depth, e.g. 1/2-inch (13 mm) of rainfall.

The CDS is designed to treat all flows up to the WQQ. At influent rates higher than the WQQ, the diversion weir will direct most flow exceeding the WQQ around the separation chamber. This allows removal efficiency to remain relatively constant in the separation chamber and eliminates the risk of washout during bypass flows regardless of influent flow rates.

Treatment flow rates are defined as the rate at which the CDS will remove a specific gradation of sediment at a specific removal efficiency. Therefore the treatment flow rate is variable, based on the gradation and removal efficiency specified by the design engineer.

Rational Rainfall Method™

Differences in local climate, topography and scale make every site hydraulically unique. It is important to take these factors into consideration when estimating the long-term performance of any stormwater treatment system. The Rational Rainfall Method combines site-specific information with laboratory generated performance data, and local historical precipitation records to estimate removal efficiencies as accurately as possible.

Short duration rain gauge records from across the United States and Canada were analyzed to determine the percent of the total annual rainfall that fell at a range of intensities. US stations' depths were totaled every 15 minutes, or hourly, and recorded in 0.01-inch increments. Depths were recorded hourly with 1-mm resolution at Canadian stations. One trend was consistent at all sites; the vast majority of precipitation fell at low intensities and high intensity storms contributed relatively little to the total annual depth.

These intensities, along with the total drainage area and runoff coefficient for each specific site, are translated into flow rates using the Rational Rainfall Method. Since most sites are relatively small and highly impervious, the Rational Rainfall Method is appropriate. Based on the runoff flow rates calculated for each intensity, operating rates within a proposed CDS system are

determined. Performance efficiency curve determined from full scale laboratory tests on defined sediment PSDs is applied to calculate solids removal efficiency. The relative removal efficiency at each operating rate is added to produce a net annual pollutant removal efficiency estimate.

Probabilistic Rational Method

The Probabilistic Rational Method is a sizing program Contech developed to estimate a net annual sediment load reduction for a particular CDS model based on site size, site runoff coefficient, regional rainfall intensity distribution, and anticipated pollutant characteristics.

The Probabilistic Method is an extension of the Rational Method used to estimate peak discharge rates generated by storm events of varying statistical return frequencies (e.g. 2-year storm event). Under the Rational Method, an adjustment factor is used to adjust the runoff coefficient estimated for the 10-year event, correlating a known hydrologic parameter with the target storm event. The rainfall intensities vary depending on the return frequency of the storm event under consideration. In general, these two frequency dependent parameters (rainfall intensity and runoff coefficient) increase as the return frequency increases while the drainage area remains constant.

These intensities, along with the total drainage area and runoff coefficient for each specific site, are translated into flow rates using the Rational Method. Since most sites are relatively small and highly impervious, the Rational Method is appropriate. Based on the runoff flow rates calculated for each intensity, operating rates within a proposed CDS are determined. Performance efficiency curve on defined sediment PSDs is applied to calculate solids removal efficiency. The relative removal efficiency at each operating rate is added to produce a net annual pollutant removal efficiency estimate.

Treatment Flow Rate

The inlet throat area is sized to ensure that the WQQ passes through the separation chamber at a water surface elevation equal to the crest of the diversion weir. The diversion weir bypasses excessive flows around the separation chamber, thus preventing re-suspension or re-entrainment of previously captured particles.

Hydraulic Capacity

The hydraulic capacity of a CDS system is determined by the length and height of the diversion weir and by the maximum allowable head in the system. Typical configurations allow hydraulic capacities of up to ten times the treatment flow rate. The crest of the diversion weir may be lowered and the inlet throat may be widened to increase the capacity of the system at a given water surface elevation. The unit is designed to meet project specific hydraulic requirements.

Performance

Full-Scale Laboratory Test Results

A full-scale CDS system (Model CDS2020-5B) was tested at the facility of University of Florida, Gainesville, FL. This CDS unit was evaluated under controlled laboratory conditions of influent flow rate and addition of sediment.

Two different gradations of silica sand material (UF Sediment & OK-110) were used in the CDS performance evaluation. The particle size distributions (PSDs) of the test materials were analyzed using standard method "Gradation ASTM D-422 "Standard Test Method for Particle-Size Analysis of Soils" by a certified laboratory.

UF Sediment is a mixture of three different products produced by the U.S. Silica Company: "Sil-Co-Sil 106", "#1 DRY" and "20/40 Oil Frac". Particle size distribution analysis shows that the UF Sediment has a very fine gradation ($d_{50} = 20$ to $30 \mu\text{m}$) covering a wide size range (Coefficient of Uniformity, C averaged at 10.6). In comparison with the hypothetical TSS gradation specified in the NJDEP (New Jersey Department of Environmental Protection) and NJCAT (New Jersey Corporation for Advanced Technology) protocol for lab testing, the UF Sediment covers a similar range of particle size but with a finer d_{50} (d_{50} for NJDEP is approximately $50 \mu\text{m}$) (NJDEP, 2003).

The OK-110 silica sand is a commercial product of U.S. Silica Sand. The particle size distribution analysis of this material, also included in Figure 1, shows that 99.9% of the OK-110 sand is finer than 250 microns, with a mean particle size (d_{50}) of 106 microns. The PSDs for the test material are shown in Figure 1.

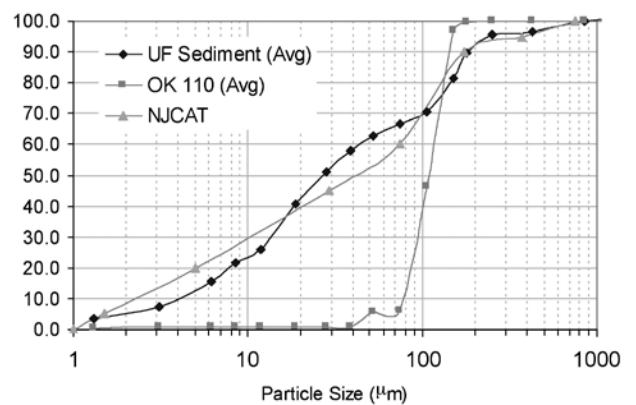

Figure 1. Particle size distributions

Tests were conducted to quantify the performance of a specific CDS unit (1.1 cfs (31.3-L/s) design capacity) at various flow rates, ranging from 1% up to 125% of the treatment design capacity of the unit, using the 2400 micron screen. All tests were conducted with controlled influent concentrations of approximately 200 mg/L. Effluent samples were taken at equal time intervals across the entire duration of each test run. These samples were then processed with a Dekaport Cone sample splitter to obtain representative sub-samples for Suspended Sediment Concentration (SSC) testing using ASTM D3977-97 "Standard Test Methods for Determining Sediment Concentration in Water Samples", and particle size distribution analysis.

Results and Modeling

Based on the data from the University of Florida, a performance model was developed for the CDS system. A regression analysis was used to develop a fitting curve representative of the scattered data points at various design flow rates. This model, which demonstrated good agreement with the laboratory data, can then be used to predict CDS system performance with respect

to SSC removal for any particle size gradation, assuming the particles are inorganic sandy-silt. Figure 2 shows CDS predictive performance for two typical particle size gradations (NJCAT gradation and OK-110 sand) as a function of operating rate.

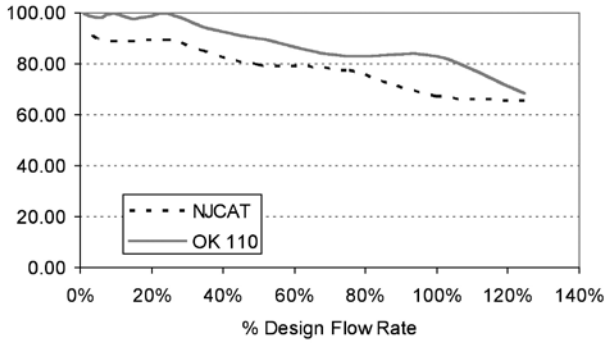

Figure 2. CDS stormwater treatment predictive performance for various particle gradations as a function of operating rate.

Many regulatory jurisdictions set a performance standard for hydrodynamic devices by stating that the devices shall be capable of achieving an 80% removal efficiency for particles having a mean particle size (d_{50}) of 125 microns (e.g. Washington State Department of Ecology — WASDOE - 2008). The model can be used to calculate the expected performance of such a PSD (shown in Figure 3). The model indicates (Figure 4) that the CDS system with 2400 micron screen achieves approximately 80% removal at the design (100%) flow rate, for this particle size distribution ($d_{50} = 125 \mu\text{m}$).

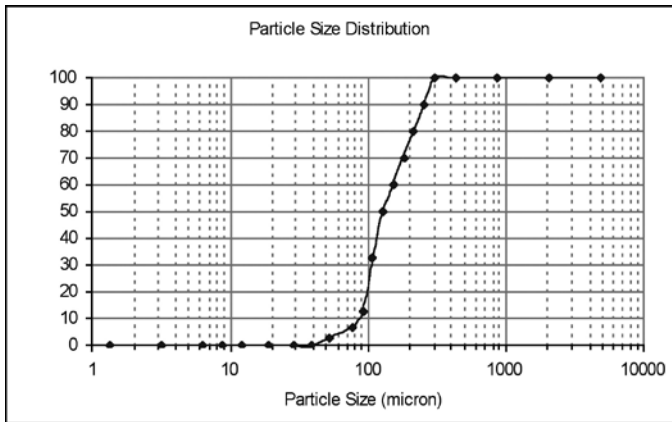

Figure 3. WASDOE PSD

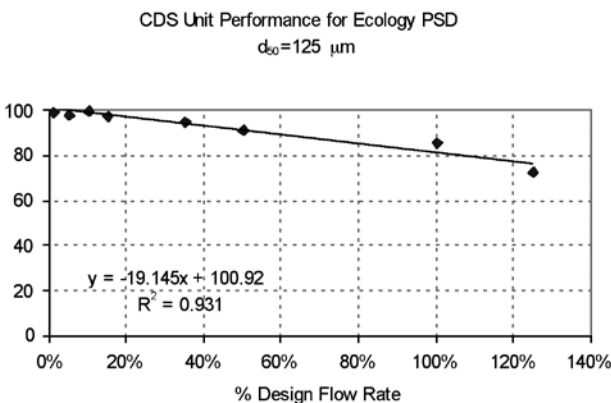

Figure 4. Modeled performance for WASDOE PSD.

Maintenance

The CDS system should be inspected at regular intervals and maintained when necessary to ensure optimum performance. The rate at which the system collects pollutants will depend more heavily on site activities than the size of the unit. For example, unstable soils or heavy winter sanding will cause the grit chamber to fill more quickly but regular sweeping of paved surfaces will slow accumulation.

Inspection

Inspection is the key to effective maintenance and is easily performed. Pollutant transport and deposition may vary from year to year and regular inspections will help ensure that the system is cleaned out at the appropriate time. At a minimum, inspections should be performed twice per year (e.g. spring and fall) however more frequent inspections may be necessary in climates where winter sanding operations may lead to rapid accumulations, or in equipment washdown areas. Installations should also be inspected more frequently where excessive amounts of trash are expected.

The visual inspection should ascertain that the system components are in working order and that there are no blockages or obstructions in the inlet and separation screen. The inspection should also quantify the accumulation of hydrocarbons, trash, and sediment in the system. Measuring pollutant accumulation can be done with a calibrated dipstick, tape measure or other measuring instrument. If absorbent material is used for enhanced removal of hydrocarbons, the level of discoloration of the sorbent material should also be identified



during inspection. It is useful and often required as part of an operating permit to keep a record of each inspection. A simple form for doing so is provided.

Access to the CDS unit is typically achieved through two manhole access covers. One opening allows for inspection and cleanout of the separation chamber (cylinder and screen) and isolated sump. The other allows for inspection and cleanout of sediment captured and retained outside the screen. For deep units, a single manhole access point would allow both sump cleanout and access outside the screen.

The CDS system should be cleaned when the level of sediment has reached 75% of capacity in the isolated sump or when an appreciable level of hydrocarbons and trash has accumulated. If absorbent material is used, it should be replaced when significant discoloration has occurred. Performance will not be impacted until 100% of the sump capacity is exceeded however it is recommended that the system be cleaned prior to that for easier removal of sediment. The level of sediment is easily determined by measuring from finished grade down to the top of the sediment pile. To avoid underestimating the level of sediment in the chamber, the measuring device must be lowered to the top of the sediment pile carefully. Particles at the top of the pile typically offer less resistance to the end of the rod than consolidated particles toward the bottom of the pile. Once this measurement is recorded, it should be compared to the as-built drawing for the unit to determine whether the height of the sediment pile off the bottom of the sump floor exceeds 75% of the total height of isolated sump.

Cleaning

Cleaning of a CDS system should be done during dry weather conditions when no flow is entering the system. The use of a vacuum truck is generally the most effective and convenient method of removing pollutants from the system. Simply remove the manhole covers and insert the vacuum hose into the sump. The system should be completely drained down and the sump fully evacuated of sediment. The area outside the screen should also be cleaned out if pollutant build-up exists in this area.

In installations where the risk of petroleum spills is small, liquid contaminants may not accumulate as quickly as sediment. However, the system should be cleaned out immediately in the event of an oil or gasoline spill. Motor oil and other hydrocarbons that accumulate on a more routine basis should be removed when an appreciable layer has been captured. To remove these pollutants, it may be preferable to use absorbent pads since they are usually less expensive to dispose than the oil/water emulsion that may be created by vacuuming the oily layer. Trash and debris can be netted out to separate it from the other pollutants. The screen should be cleaned to ensure it is free of trash and debris.

Manhole covers should be securely seated following cleaning activities to prevent leakage of runoff into the system from above and also to ensure that proper safety precautions have been followed. Confined space entry procedures need to be followed if physical access is required. Disposal of all material removed from the CDS system should be done in accordance with local regulations. In many jurisdictions, disposal of the sediments may be handled in the same manner as the disposal of sediments removed from catch basins or deep sump manholes. Check your local regulations for specific requirements on disposal.



CDS Model	Diameter		Distance from Water Surface to Top of Sediment Pile		Sediment Storage Capacity	
	ft	m	ft	m	y ³	m ³
CDS1515	3	0.9	3.0	0.9	0.5	0.4
CDS2015	4	1.2	3.0	0.9	0.9	0.7
CDS2015	5	1.5	3.0	0.9	1.3	1.0
CDS2020	5	1.5	3.5	1.1	1.3	1.0
CDS2025	5	1.5	4.0	1.2	1.3	1.0
CDS3020	6	1.8	4.0	1.2	2.1	1.6
CDS3025	6	1.8	4.0	1.2	2.1	1.6
CDS3030	6	1.8	4.6	1.4	2.1	1.6
CDS3035	6	1.8	5.0	1.5	2.1	1.6
CDS4030	8	2.4	4.6	1.4	5.6	4.3
CDS4040	8	2.4	5.7	1.7	5.6	4.3
CDS4045	8	2.4	6.2	1.9	5.6	4.3
CDS5640	10	3.0	6.3	1.9	8.7	6.7
CDS5653	10	3.0	7.7	2.3	8.7	6.7
CDS5668	10	3.0	9.3	2.8	8.7	6.7
CDS5678	10	3.0	10.3	3.1	8.7	6.7

Table 1: CDS Maintenance Indicators and Sediment Storage Capacities

Note: To avoid underestimating the volume of sediment in the chamber, carefully lower the measuring device to the top of the sediment pile. Finer silty particles at the top of the pile may be more difficult to feel with a measuring stick. These finer particles typically offer less resistance to the end of the rod than larger particles toward the bottom of the pile.

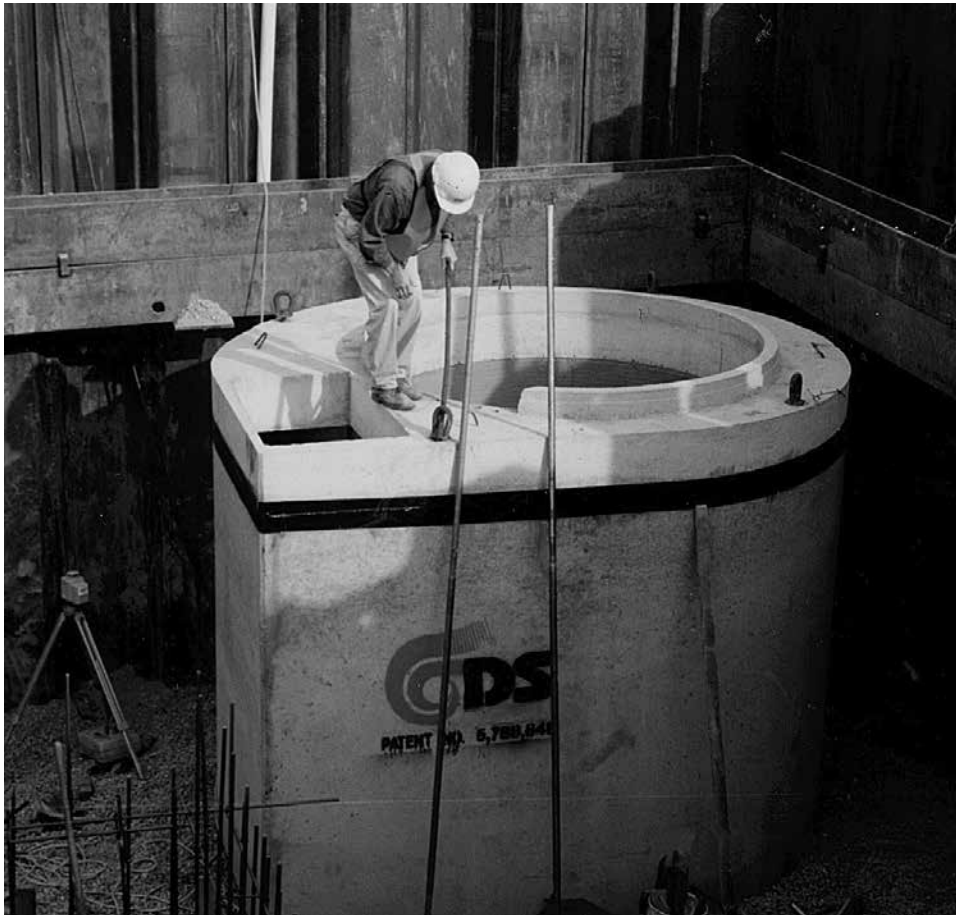

SUPPORT

- Drawings and specifications are available at www.ContechES.com.
- Site-specific design support is available from our engineers.



800-338-1122

www.ContechES.com

©2017 Contech Engineered Solutions LLC, a QUIKRETE Company

Contech Engineered Solutions provides site solutions for the civil engineering industry. Contech's portfolio includes bridges, drainage, sanitary sewer, earth stabilization and stormwater treatment products. For information on other Contech division offerings, visit www.ContechES.com or call 800.338.1122

NOTHING IN THIS CATALOG SHOULD BE CONSTRUED AS A WARRANTY. APPLICATIONS SUGGESTED HEREIN ARE DESCRIBED ONLY TO HELP READERS MAKE THEIR OWN EVALUATIONS AND DECISIONS, AND ARE NEITHER GUARANTEES NOR WARRANTIES OF SUITABILITY FOR ANY APPLICATION. CONTECH MAKES NO WARRANTY WHATSOEVER, EXPRESS OR IMPLIED, RELATED TO THE APPLICATIONS, MATERIALS, COATINGS, OR PRODUCTS DISCUSSED HEREIN. ALL IMPLIED WARRANTIES OF MERCHANTABILITY AND ALL IMPLIED WARRANTIES OF FITNESS FOR ANY PARTICULAR PURPOSE ARE DISCLAIMED BY CONTECH. SEE CONTECH'S CONDITIONS OF SALE (AVAILABLE AT WWW.CONTECHES.COM/COS) FOR MORE INFORMATION.

The product(s) described may be protected by one or more of the following US patents: 5,322,629; 5,624,576; 5,707,527; 5,759,415; 5,788,848; 5,985,157; 6,027,639; 6,350,374; 6,406,218; 6,641,720; 6,511,595; 6,649,048; 6,991,114; 6,998,038; 7,186,058; 7,296,692; 7,297,266; related foreign patents or other patents pending.



Appendix F

Hydrologic Analysis - Input Computations

Wake Robin Inn Redevelopment

104 & 106 Sharon Road, Salisbury, Connecticut

Drainage Report

Prepared for:
Aradev LLC
352 Atlantic Avenue, Unit 2
Brooklyn, NY 11217

SLR Project No.: 141.22100.00001

April 25, 2025

Revised July 28, 2025



Curve Number Calculations

Project: Wake Robin Inn Redevelopment
 Location: 104 & 106 Sharon Road
Salisbury, CT

By: MCB Date: Rev. 8/29/24 Checked: TDR Date: 11/4/24
 Circle one: **Present** Developed Watershed: EXWS-10

Soil Name and Hydrologic Group (appendix A)	Cover Description (cover type, treatment, and hydrologic condition; percent impervious; unconnected/connected impervious area ratio)	CN Value ^{1.}			Area Acres Sq. Ft. %	Product of CN x Area
		Table 2-2	Figure 2-3	Figure 2-4		
B Soil	Woods - Good Condition	55			0.11	5.86
B Soil	Gravel	96			0.01	0.75
D Soil	Woods - Good Condition	77			2.29	176.68
D Soil	Open Space - Good Condition	80			0.01	0.83
N/A	Existing Building	98			0.04	3.59
Totals =					2.46	187.72
					(0.00384	sq mi)

CN (weighted) = $\frac{\text{total product}}{\text{total area}}$ = $\frac{187.72}{2.46}$ Use CN = 76



Curve Number Calculations

Project: Wake Robin Inn Redevelopment

Location: 104 & 106 Sharon Road

Salisbury, CT

By: MCB Date: Rev. 8/29/24

Checked: TDR

Date: 11/4/24

Circle one: **Present** Developed

Watershed: EXWS-11

Soil Name and Hydrologic Group (appendix A)	Cover Description (cover type, treatment, and hydrologic condition; percent impervious; unconnected/connected impervious area ratio)	CN Value ¹ :			Area Acres Sq. Ft. %	Product of CN x Area
		Table 2-2	Figure 2-3	Figure 2-4		
B Soil	Woods - Good Condition	55			2.80	154.20
B Soil	Open Space - Good Condition	61			0.94	57.07
B Soil	Gravel	96			0.34	32.72
C Soil	Woods - Good Condition	70			1.52	106.74
D Soil	Woods - Good Condition	77			9.40	723.63
D Soil	Open Space - Good Condition	80			0.73	58.06
D Soil	Gravel	96			0.06	5.79
N/A	Paved/Impervious	98			0.08	7.44
N/A	Existing Building	98			0.19	18.46
Totals =					16.05	1164.11

(0.02508 sq mi)

CN (weighted) = $\frac{\text{total product}}{\text{total area}}$ = $\frac{1164.11}{16.05}$ Use CN = 73



Curve Number Calculations

Project: Wake Robin Inn Redevelopment
 Location: 104 & 106 Sharon Road
Salisbury, CT

By: MCB Date: Rev. 8/29/24 Checked: TDR Date: 11/4/24
 Circle one: Present Developed Watershed: EXWS-20

Soil Name and Hydrologic Group (appendix A)	Cover Description (cover type, treatment, and hydrologic condition; percent impervious; unconnected/connected impervious area ratio)	CN Value ^{1.}			Area Acres Sq. Ft. %	Product of CN x Area
		Table 2-2	Figure 2-3	Figure 2-4		
D Soil	Woods - Good Condition	77			3.39	261.35
D Soil	Open Space - Good Condition	80			0.51	40.91
D Soil	Gravel	96			0.38	36.78
N/A	Paved/Impervious	98			0.31	30.81
N/A	Existing Building	98			0.39	38.48
Totals =					5.00	408.33

(0.00781 sq mi)

CN (weighted) = $\frac{\text{total product}}{\text{total area}}$ = $\frac{408.33}{5.00}$ Use CN = 82



Curve Number Calculations

Project: Wake Robin Inn Redevelopment
 Location: 104 & 106 Sharon Road
Salisbury, CT

By: MCB Date: Rev. 8/29/24 Checked: TDR Date: 11/4/24
 Circle one: **Present** Developed Watershed: EXWS-30

Soil Name and Hydrologic Group (appendix A)	Cover Description (cover type, treatment, and hydrologic condition; percent impervious; unconnected/connected impervious area ratio)	CN Value ^{1.}			Area Acres Sq. Ft. %	Product of CN x Area
		Table 2-2	Figure 2-3	Figure 2-4		
D Soil	Woods - Good Condition	77			1.66	127.98
N/A	Existing Building	98			0.01	1.00
Totals =					1.67	128.98

(0.00261 sq mi)

CN (weighted) = $\frac{\text{total product}}{\text{total area}}$ = $\frac{128.98}{1.67}$ Use CN = 77



Curve Number Calculations

Project: Wake Robin Inn Redevelopment
 Location: 104 & 106 Sharon Road
Salisbury, CT

By: MCB Date: Rev. 4/17/25 Checked: TDR Date: 4/17/25
 Circle one: Present **Developed** Watershed: PRWS-10

Soil Name and Hydrologic Group (appendix A)	Cover Description (cover type, treatment, and hydrologic condition; percent impervious; unconnected/connected impervious area ratio)	CN Value ^{1.}			Area <u>Acres</u> Sq. Ft. %	Product of CN x Area
		Table 2-2	Figure 2-3	Figure 2-4		
B Soil	Woods - Good Condition	55			0.05	2.80
B Soil	Open Space - Good Condition	61			0.08	4.86
B Soil	Gravel	85			0.01	0.65
D Soil	Woods - Good Condition	77			0.83	64.14
D Soil	Open Space - Good Condition	80			0.54	43.60
D Soil	Gravel	91			0.03	2.59
N/A	Paved/Impervious	98			0.04	3.89
N/A	Building	98			0.02	1.53
Totals =					1.60	124.05
					(0.00250	sq mi)

$$\text{CN (weighted)} = \frac{\text{total product}}{\text{total area}} = \frac{124.05}{1.60} \quad \text{Use CN} = \boxed{78}$$

Curve Number Calculations

Project: Wake Robin Inn Redevelopment
 Location: 104 & 106 Sharon Road
Salisbury, CT

By: MCB Date: Rev. 4/17/25 Checked: TDR Date: 4/17/25
 Circle one: Present **Developed** Watershed: PRWS-11

Soil Name and Hydrologic Group (appendix A)	Cover Description (cover type, treatment, and hydrologic condition; percent impervious; unconnected/connected impervious area ratio)	CN Value ^{1.}			Area <u>Acres</u> Sq. Ft. %	Product of CN x Area
		Table 2-2	Figure 2-3	Figure 2-4		
B Soil	Woods - Good Condition	55			2.65	145.54
B Soil	Open Space - Good Condition	61			1.32	80.47
B Soil	Gravel	96			0.04	4.26
C Soil	Woods - Good Condition	70			1.52	106.74
D Soil	Woods - Good Condition	77			8.24	634.59
D Soil	Open Space - Good Condition	80			1.08	86.11
D Soil	Gravel	96			0.12	11.36
N/A	Paved/Impervious	98			0.49	48.46
N/A	Building	98			0.46	44.95
Totals =					15.92	1162.48

(0.02488 sq mi)

$$\text{CN (weighted)} = \frac{\text{total product}}{\text{total area}} = \frac{1162.48}{15.92} \quad \text{Use CN} = \boxed{73}$$

Curve Number Calculations

Project: Wake Robin Inn Redevelopment
 Location: 104 & 106 Sharon Road
Salisbury, CT

By: MCB Date: Rev. 4/17/25 Checked: TDR Date: 4/17/25
 Circle one: Present **Developed** Watershed: PRWS-14

Soil Name and Hydrologic Group (appendix A)	Cover Description (cover type, treatment, and hydrologic condition; percent impervious; unconnected/connected impervious area ratio)	CN Value ^{1.}			Area <u>Acres</u> Sq. Ft. %	Product of CN x Area
		Table 2-2	Figure 2-3	Figure 2-4		
D Soil	Woods	77			0.02	1.60
D Soil	Open Space - Good Condition	80			0.21	17.03
D Soil	Gravel	96			0.05	4.40
N/A	Paved/Impervious	98			0.05	4.92
Totals =					0.33	27.94
					(0.00051	sq mi)

CN (weighted) = $\frac{\text{total product}}{\text{total area}}$ = $\frac{27.94}{0.33}$ Use CN = 85



Curve Number Calculations

Project: Wake Robin Inn Redevelopment
 Location: 104 & 106 Sharon Road
Salisbury, CT

By: MCB Date: Rev. 4/17/25 Checked: TDR Date: 4/17/25
 Circle one: Present **Developed** Watershed: PRWS-20

Soil Name and Hydrologic Group (appendix A)	Cover Description (cover type, treatment, and hydrologic condition; percent impervious; unconnected/connected impervious area ratio)	CN Value ^{1.}			Area <u>Acres</u> Sq. Ft. %	Product of CN x Area
		Table 2-2	Figure 2-3	Figure 2-4		
D Soil	Woods - Good Condition	77			1.27	97.70
D Soil	Open Space - Good Condition	80			0.86	68.77
D Soil	Gravel	96			0.06	5.84
N/A	Paved/Impervious	98			0.39	38.45
Totals =					2.58	210.76
					(0.00403	sq mi)

CN (weighted) = $\frac{\text{total product}}{\text{total area}}$ = $\frac{210.76}{2.58}$ Use CN = 82



Curve Number Calculations

Project: Wake Robin Inn Redevelopment
 Location: 104 & 106 Sharon Road
Salisbury, CT

By: MCB Date: Rev. 4/17/25 Checked: TDR Date: 4/17/25
 Circle one: Present **Developed** Watershed: PRWS-21

Soil Name and Hydrologic Group (appendix A)	Cover Description (cover type, treatment, and hydrologic condition; percent impervious; unconnected/connected impervious area ratio)	CN Value ^{1.}			Area <u>Acres</u> Sq. Ft. %	Product of CN x Area
		Table 2-2	Figure 2-3	Figure 2-4		
D Soil	Woods - Good Condition	77			0.15	11.77
D Soil	Open Space - Good Condition	80			1.27	101.29
D Soil	Gravel	96			0.16	15.48
N/A	Paved/Impervious	98			0.77	75.75
N/A	Building	98			0.49	47.89
Totals =					2.84	252.18

(0.00444 sq mi)

CN (weighted) = $\frac{\text{total product}}{\text{total area}}$ = $\frac{252.18}{2.84}$ Use CN = 89



Curve Number Calculations

Project: Wake Robin Inn Redevelopment
 Location: 104 & 106 Sharon Road
Salisbury, CT

By: MCB Date: Rev. 12/9/24 Checked: TDR Date: 12/9/24
 Circle one: Present **Developed** Watershed: PRWS-22

Soil Name and Hydrologic Group (appendix A)	Cover Description (cover type, treatment, and hydrologic condition; percent impervious; unconnected/connected impervious area ratio)	CN Value ^{1.}			Area <u>Acres</u> Sq. Ft. %	Product of CN x Area
		Table 2-2	Figure 2-3	Figure 2-4		
D Soil	Woods - Good Condition	77			0.01	0.99
D Soil	Open Space - Good Condition	80			0.31	24.45
D Soil	Gravel	96			0.19	18.21
N/A	Paved/Impervious	98			0.24	23.11
N/A	Building	98			0.02	1.94
Totals =					0.76	68.70
					(0.00119	sq mi)

CN (weighted) = $\frac{\text{total product}}{\text{total area}}$ = $\frac{68.70}{0.76}$ Use CN = 90



Curve Number Calculations

Project: Wake Robin Inn Redevelopment
 Location: 104 & 106 Sharon Road
Salisbury, CT

By: MCB Date: Rev. 4/17/25 Checked: TDR Date: 4/17/25
 Circle one: Present **Developed** Watershed: PRWS-30

Soil Name and Hydrologic Group (appendix A)	Cover Description (cover type, treatment, and hydrologic condition; percent impervious; unconnected/connected impervious area ratio)	CN Value ^{1.}			Area <u>Acres</u> Sq. Ft. %	Product of CN x Area
		Table 2-2	Figure 2-3	Figure 2-4		
D Soil	Woods - Good Condition	77			0.73	55.93
D Soil	Open Space - Good Condition	80			0.39	31.51
N/A	Paved/Impervious	98			0.01	0.74
Totals =					1.13	88.18
					(0.00176	sq mi)

CN (weighted) = $\frac{\text{total product}}{\text{total area}}$ = $\frac{88.18}{1.13}$ Use CN = 78



Time of Concentration (T_c) or Travel Time (T_t) Worksheet

Project: Wake Robin Inn Redevelopment
 Location: Salisbury, CT
 Circle one: Present Developed
 Circle one: T_c T_t

By: MCB
 Checked: TDR
 Watershed: EXWS-10
 Subwatershed: _____

Date: 07/19/24
 Date: 11/04/24

Sheet flow (applicable to T_c only)

1. Surface description (Table 3-1)
2. Manning's roughness coeff. for sheet flow, n (Table 3-1)
3. Flow Length, L (< 300ft)
4. Two-year 24-hr rainfall, P_2
5. Land slope, s
6. $T_t = \frac{0.007 (nL)^{0.8}}{P_2^{0.5} (s^{0.4})}$

Segment ID	A-B				
	WOODS				
	0.400				
ft.	100.0				
in.	3.08				
ft./ft.	0.070				
hr.	0.221	=			0.221

Shallow concentrated flow (assume hyd. radius = depth of flow)

7. Surface description
8. Manning's roughness coeff., n
9. Paved or unpaved
10. Depth of flow, d (default values: d=.4 unpaved, d=.2 paved) ft.
11. Flow Length, L
12. Watercourse slope, s
13. Average velocity, $V = \frac{1.49}{n} (d^{2/3})(s^{1/2})$
14. $T_t = \frac{L}{3600 * V}$

Segment ID	B-C				
	WOODS				
	0.100				
	UNPVD				
ft.	0.40				
ft.	108.0				
ft./ft.	0.056				
fps.	1.91				
hr.	0.016				= 0.016

Channel flow

15. Channel Bottom width, b
16. Horizontal side slope component, z (z horiz:1 vert)
17. Depth of flow, d
18. Cross sectional flow area, A (assume trapazoidal) ft.²
19. Wetted perimeter, P_w
20. Hydraulic Radius, $R = \frac{A}{P_w}$
21. Channel slope, s
22. Manning's roughness coeff., n
23. $V = \frac{1.49}{n} (R^{2/3})(s^{1/2})$
24. Flow length, L
25. $T_t = \frac{L}{3600 * V}$
26. Watershed or subarea T_c or T_t (add T_t in steps 6, 14 & 25)

Segment ID					
ft.					
ft.					
ft.					
ft. ²					
ft.					
ft.					
ft./ft.					
fps.					
ft.					
hr.					= 0.000
hr.					0.237

Time of Concentration (T_c) or Travel Time (T_t) Worksheet

Project: Wake Robin Inn Redevelopment
 Location: Salisbury, CT
 Circle one: Present Developed
 Circle one: T_c T_t

By: MCB Date: 07/19/24
 Checked: TDR Date: 11/04/24
 Watershed: EXWS-11
 Subwatershed: _____

Sheet flow (applicable to T_c only)

1. Surface description (Table 3-1)
2. Manning's roughness coeff. for sheet flow, n (Table 3-1)
3. Flow Length, L (< 300ft)
4. Two-year 24-hr rainfall, P_2
5. Land slope, s
6. $T_t = \frac{0.007 (nL)^{0.8}}{P_2^{0.5} (s^{0.4})}$

Segment ID	A-B				
	WOODS				
	0.400				
	ft. 100.0				
	in. 3.08				
	ft./ft. 0.035				
	hr. 0.292	=			0.292

Shallow concentrated flow (assume hyd. radius = depth of flow)

7. Surface description
8. Manning's roughness coeff., n
9. Paved or unpaved
10. Depth of flow, d (default values: d=.4 unpaved, d=.2 paved) ft.
11. Flow Length, L
12. Watercourse slope, s
13. Average velocity, $V = \frac{1.49}{n} (d^{2/3})(s^{1/2})$
14. $T_t = \frac{L}{3600 * V}$

Segment ID	B-C				
	WOODS				
	0.100				
	UNPVD				
	ft. 0.40				
	ft. 1176.0				
	ft./ft. 0.013				
	fps. 0.92				
	hr. 0.354				= 0.354

Channel flow

15. Channel Bottom width, b
16. Horizontal side slope component, z (z horiz:1 vert) ft.
17. Depth of flow, d
18. Cross sectional flow area, A (assume trapazoidal) ft.²
19. Wetted perimeter, P_w
20. Hydraulic Radius, $R = \frac{A}{P_w}$
21. Channel slope, s
22. Manning's roughness coeff., n
23. $V = \frac{1.49}{n} (R^{2/3})(s^{1/2})$
24. Flow length, L
25. $T_t = \frac{L}{3600 * V}$
26. Watershed or subarea T_c or T_t (add T_t in steps 6, 14 & 25)

Segment ID	C-D	D-E			
	ft. 12" RCP	6.00			
	ft. --	4.00			
	ft. FULL	1.00			
	ft. ² 0.79	10.00			
	ft. 3.14	14.25			
	ft. 0.25	0.70			
	ft./ft. 0.006	0.057			
	0.013	0.024			
	fps. 3.54	11.71			
	ft. 31.0	514.0			
	hr. 0.002	0.012	+		
					= 0.015
					0.660
					hr.

Time of Concentration (T_c) or Travel Time (T_t) Worksheet

Project: Wake Robin Inn Redevelopment
 Location: Salisbury, CT
 Circle one: Present Developed
 Circle one: T_c T_t

By: MCB
 Checked: TDR
 Watershed: EXWS-20
 Subwatershed: _____

Date: 07/19/24
 Date: 11/04/24

Sheet flow (applicable to T_c only)

1. Surface description (Table 3-1)
2. Manning's roughness coeff. for sheet flow, n (Table 3-1)
3. Flow Length, L (< 300ft)
4. Two-year 24-hr rainfall, P_2
5. Land slope, s
6. $T_t = \frac{0.007 (nL)^{0.8}}{P_2^{0.5} (s^{0.4})}$

Segment ID	A-B				
	WOODS				
	0.400				
ft.	100.0				
in.	3.08				
ft./ft.	0.060				
hr.	0.235	=			0.235

Shallow concentrated flow (assume hyd. radius = depth of flow)

7. Surface description
8. Manning's roughness coeff., n
9. Paved or unpaved
10. Depth of flow, d (default values: d=.4 unpaved, d=.2 paved) ft.
11. Flow Length, L
12. Watercourse slope, s
13. Average velocity, $V = \frac{1.49}{n} (d^{2/3})(s^{1/2})$
14. $T_t = \frac{L}{3600 * V}$

Segment ID	B-C	C-D	D-E		
	WOODS	BIT	WOODS		
	0.100	0.010	0.100		
	UNPVD	PVD	UNPVD		
ft.	0.40	0.20	0.40		
ft.	40.0	159.0	52.0		
ft./ft.	0.100	0.107	0.096		
fps.	2.56	16.67	2.51		
hr.	0.004	+	0.003	+	
			0.006	=	
					0.013

Channel flow

15. Channel Bottom width, b
16. Horizontal side slope component, z (z horiz:1 vert)
17. Depth of flow, d
18. Cross sectional flow area, A (assume trapazoidal) $ft.^2$
19. Wetted perimeter, P_w
20. Hydraulic Radius, $R = \frac{A}{P_w}$
21. Channel slope, s
22. Manning's roughness coeff., n
23. $V = \frac{1.49}{n} (R^{2/3})(s^{1/2})$
24. Flow length, L
25. $T_t = \frac{L}{3600 * V}$
26. Watershed or subarea T_c or T_t (add T_t in steps 6, 14 & 25)

Segment ID					
ft.					
ft.					
$ft.^2$					
ft.					
ft.					
ft./ft.					
fps.					
ft.					
hr.				=	
					0.000
					0.248

Time of Concentration (T_c) or Travel Time (T_t) Worksheet

Project: Wake Robin Inn Redevelopment
 Location: Salisbury, CT
 Circle one: Present Developed
 Circle one: T_c T_t

By: MCB
 Checked: TDR
 Watershed: EXWS-30
 Subwatershed: _____

Date: 07/25/25
 Date: 07/25/25

Sheet flow (applicable to T_c only)

1. Surface description (Table 3-1)
2. Manning's roughness coeff. for sheet flow, n (Table 3-1)
3. Flow Length, L (< 300ft)
4. Two-year 24-hr rainfall, P_2
5. Land slope, s
6. $T_t = \frac{0.007 (nL)^{0.8}}{P_2^{0.5} (s^{0.4})}$

Segment ID	A-B
	WOODS
	0.400
ft.	100.0
in.	3.08
ft./ft.	0.080
hr.	0.210

=

0.210

Shallow concentrated flow (assume hyd. radius = depth of flow)

7. Surface description
8. Manning's roughness coeff., n
9. Paved or unpaved
10. Depth of flow, d (default values: d=.4 unpaved, d=.2 paved) ft.
11. Flow Length, L
12. Watercourse slope, s
13. Average velocity, $V = \frac{1.49}{n} (d^{2/3})(s^{1/2})$
14. $T_t = \frac{L}{3600 * V}$

Segment ID	B-C			
	WOODS			
	0.100			
	UNPVD			
ft.	0.40			
ft./ft.	0.056			
fps.	1.91			
hr.	0.002			

=

0.002

Channel flow

15. Channel Bottom width, b
16. Horizontal side slope component, z (z horiz:1 vert)
17. Depth of flow, d
18. Cross sectional flow area, A (assume trapazoidal) $ft.^2$
19. Wetted perimeter, P_w
20. Hydraulic Radius, $R = \frac{A}{P_w}$
21. Channel slope, s
22. Manning's roughness coeff., n
23. $V = \frac{1.49}{n} (R^{2/3})(s^{1/2})$
24. Flow length, L
25. $T_t = \frac{L}{3600 * V}$
26. Watershed or subarea T_c or T_t (add T_t in steps 6, 14 & 25)

Segment ID				
ft.				
ft.				
ft.				
$ft.^2$				
ft.				
ft.				
ft./ft.				
fps.				
ft.				
hr.				

=

0.000

hr.

0.212

Time of Concentration (T_c) or Travel Time (T_t) Worksheet

Project: Wake Robin Inn Redevelopment
 Location: Salisbury, CT
 Circle one: Present Developed
 Circle one: T_c T_t

By: MCB
 Checked: TDR
 Watershed: PRWS-11
 Subwatershed: _____
 Date: Rev. 12/9/24
 Date: 12/09/24

Sheet flow (applicable to T_c only)

1. Surface description (Table 3-1)
2. Manning's roughness coeff. for sheet flow, n (Table 3-1)
3. Flow Length, L (< 300ft)
4. Two-year 24-hr rainfall, P_2
5. Land slope, s
6. $T_t = \frac{0.007 (nL)^{0.8}}{P_2^{0.5} (s^{0.4})}$

Segment ID	A-B			
	WOODS			
	0.400			
	ft. 100.0			
	in. 3.08			
	ft./ft. 0.035			
	hr. 0.292	=		0.292

Shallow concentrated flow (assume hyd. radius = depth of flow)

7. Surface description
8. Manning's roughness coeff., n
9. Paved or unpaved
10. Depth of flow, d (default values: d=.4 unpaved, d=.2 paved) ft.
11. Flow Length, L
12. Watercourse slope, s
13. Average velocity, $V = \frac{1.49}{n} (d^{2/3})(s^{1/2})$
14. $T_t = \frac{L}{3600 * V}$

Segment ID	B-C			
	WOODS			
	0.100			
	UNPVD			
	ft. 0.40			
	ft. 1176.0			
	ft./ft. 0.013			
	fps. 0.92			
	hr. 0.354			= 0.354

Channel flow

15. Channel Bottom width, b
16. Horizontal side slope component, z (z horiz:1 vert)
17. Depth of flow, d
18. Cross sectional flow area, A (assume trapazoidal) ft.²
19. Wetted perimeter, P_w
20. Hydraulic Radius, $R = \frac{A}{P_w}$
21. Channel slope, s
22. Manning's roughness coeff., n
23. $V = \frac{1.49}{n} (R^{2/3})(s^{1/2})$
24. Flow length, L
25. $T_t = \frac{L}{3600 * V}$
26. Watershed or subarea T_c or T_t (add T_t in steps 6, 14 & 25)

Segment ID	C-D			
	ft. 6.00			
	ft. 4.00			
	ft. 1.00			
	ft. ² 10.00			
	ft. 14.25			
	ft. 0.70			
	ft./ft. 0.057			
	0.024			
	fps. 11.71			
	ft. 545.0			
	hr. 0.013	+		= 0.013
				0.659

Time of Concentration (T_c) or Travel Time (T_t) Worksheet

Project: Wake Robin Inn Redevelopment
 Location: Salisbury, CT
 Circle one: Present Developed
 Circle one: T_c T_t

By: MCB Date: Rev. 12/9/24
 Checked: TDR Date: 12/09/24
 Watershed: PRWS-12
 Subwatershed: _____

Sheet flow (applicable to T_c only)

1. Surface description (Table 3-1)
2. Manning's roughness coeff. for sheet flow, n (Table 3-1)
3. Flow Length, L (< 300ft)
4. Two-year 24-hr rainfall, P_2
5. Land slope, s
6. $T_t = \frac{0.007 (nL)^{0.8}}{P_2^{0.5} (s^{0.4})}$

Segment ID	A-B
	GRASS
	0.240
ft.	107.0
in.	3.08
ft./ft.	0.070
hr.	0.155

=

0.155

Shallow concentrated flow (assume hyd. radius = depth of flow)

7. Surface description
8. Manning's roughness coeff., n
9. Paved or unpaved
10. Depth of flow, d (default values: d=.4 unpaved, d=.2 paved) ft.
11. Flow Length, L
12. Watercourse slope, s
13. Average velocity, $V = \frac{1.49}{n} (d^{2/3})(s^{1/2})$
14. $T_t = \frac{L}{3600 * V}$

Segment ID				
ft.				
ft./ft.				
fps.				
hr.				

+

0.000

Channel flow

15. Channel Bottom width, b
16. Horizontal side slope component, z (z horiz:1 vert)
17. Depth of flow, d
18. Cross sectional flow area, A (assume trapazoidal) ft.²
19. Wetted perimeter, P_w
20. Hydraulic Radius, $R = \frac{A}{P_w}$
21. Channel slope, s
22. Manning's roughness coeff., n
23. $V = \frac{1.49}{n} (R^{2/3})(s^{1/2})$
24. Flow length, L
25. $T_t = \frac{L}{3600 * V}$
26. Watershed or subarea T_c or T_t (add T_t in steps 6, 14 & 25)

Segment ID				
ft.				
ft.				
ft. ²				
ft.				
ft.				
ft./ft.				
fps.				
ft.				
hr.				

=

0.000

=

0.155

Time of Concentration (T_c) or Travel Time (T_t) Worksheet

Project: Wake Robin Inn Redevelopment
 Location: Salisbury, CT
 Circle one: Present Developed
 Circle one: T_c T_t

By: MCB Date: Rev. 4/17/25
 Checked: TDR Date: 04/17/25
 Watershed: PRWS-14
 Subwatershed: _____

Sheet flow (applicable to T_c only)

1. Surface description (Table 3-1)
2. Manning's roughness coeff. for sheet flow, n (Table 3-1)
3. Flow Length, L (< 300ft)
4. Two-year 24-hr rainfall, P_2
5. Land slope, s
6. $T_t = \frac{0.007 (nL)^{0.8}}{P_2^{0.5} (s^{0.4})}$

Segment ID	A-B				
	GRASS				
	0.240				
ft.	100.0				
in.	3.08				
ft./ft.	0.100				
hr.	0.127	=			0.127

Shallow concentrated flow (assume hyd. radius = depth of flow)

7. Surface description
8. Manning's roughness coeff., n
9. Paved or unpaved
10. Depth of flow, d (default values: d=.4 unpaved, d=.2 paved) ft.
11. Flow Length, L
12. Watercourse slope, s
13. Average velocity, $V = \frac{1.49}{n} (d^{2/3})(s^{1/2})$
14. $T_t = \frac{L}{3600 * V}$

Segment ID	B-C				
	GRASS				
	0.080				
	UNPVD				
ft.	0.40				
ft./ft.	0.194				
fps.	4.45				
hr.	0.001				= 0.001

Channel flow

15. Channel Bottom width, b
16. Horizontal side slope component, z (z horiz:1 vert)
17. Depth of flow, d
18. Cross sectional flow area, A (assume trapazoidal) $ft.^2$
19. Wetted perimeter, P_w
20. Hydraulic Radius, $R = \frac{A}{P_w}$
21. Channel slope, s
22. Manning's roughness coeff., n
23. $V = \frac{1.49}{n} (R^{2/3})(s^{1/2})$
24. Flow length, L
25. $T_t = \frac{L}{3600 * V}$
26. Watershed or subarea T_c or T_t (add T_t in steps 6, 14 & 25)

Segment ID					
ft.					
ft.					
$ft.^2$					
ft.					
ft.					
ft./ft.					
fps.					
ft.					
hr.					= 0.000
hr.					0.128

Time of Concentration (T_c) or Travel Time (T_t) Worksheet

Project: Wake Robin Inn Redevelopment
 Location: Salisbury, CT
 Circle one: Present Developed
 Circle one: T_c T_t

By: MCB
 Checked: TDR
 Watershed: PRWS-20
 Subwatershed: _____
 Date: Rev. 12/9/24
 Date: 12/09/24

Sheet flow (applicable to T_c only)

1. Surface description (Table 3-1)
2. Manning's roughness coeff. for sheet flow, n (Table 3-1)
3. Flow Length, L (< 300ft)
4. Two-year 24-hr rainfall, P_2
5. Land slope, s
6. $T_t = \frac{0.007 (nL)^{0.8}}{P_2^{0.5} (s^{0.4})}$

Segment ID	A-B				
	WOODS				
	0.400				
ft.	100.0				
in.	3.08				
ft./ft.	0.060				
hr.	0.235	=			0.235

Shallow concentrated flow (assume hyd. radius = depth of flow)

7. Surface description
8. Manning's roughness coeff., n
9. Paved or unpaved
10. Depth of flow, d (default values: d=.4 unpaved, d=.2 paved) ft.
11. Flow Length, L
12. Watercourse slope, s
13. Average velocity, $V = \frac{1.49}{n} (d^{2/3})(s^{1/2})$
14. $T_t = \frac{L}{3600 * V}$

Segment ID	B-C				
	GRASS				
	0.080				
	UNPVD				
ft.	0.40				
ft.	240.0				
ft./ft.	0.100				
fps.	3.20				
hr.	0.021	+			= 0.021

Channel flow

15. Channel Bottom width, b
16. Horizontal side slope component, z (z horiz:1 vert) ft.
17. Depth of flow, d
18. Cross sectional flow area, A (assume trapazoidal) ft.²
19. Wetted perimeter, P_w
20. Hydraulic Radius, $R = \frac{A}{P_w}$
21. Channel slope, s
22. Manning's roughness coeff., n
23. $V = \frac{1.49}{n} (R^{2/3})(s^{1/2})$
24. Flow length, L
25. $T_t = \frac{L}{3600 * V}$
26. Watershed or subarea T_c or T_t (add T_t in steps 6, 14 & 25)

Segment ID	E-F				
ft.	15" HDPE				
	--				
ft.	FULL				
ft. ²	1.23				
ft.	3.93				
ft.	0.31				
ft./ft.	0.04				
	0.012				
fps.	11.45				
ft.	385.0				
hr.	0.009				= 0.009
hr.					0.265

Time of Concentration (T_c) or Travel Time (T_t) Worksheet

Project: Wake Robin Inn Redevelopment
 Location: Salisbury, CT
 Circle one: Present Developed
 Circle one: T_c T_t

By: MCB Date: Rev. 4/17/25
 Checked: TDR Date: 04/17/25
 Watershed: PRWS-21
 Subwatershed: _____

Sheet flow (applicable to T_c only)

1. Surface description (Table 3-1)
2. Manning's roughness coeff. for sheet flow, n (Table 3-1)
3. Flow Length, L (< 300ft)
4. Two-year 24-hr rainfall, P_2
5. Land slope, s
6. $T_t = \frac{0.007 (nL)^{0.8}}{P_2^{0.5} (s^{0.4})}$

Segment ID	A-B				
	GRASS				
	0.240				
ft.	100.0				
in.	3.08				
ft./ft.	0.080				
hr.	0.139	=		0.139	

Shallow concentrated flow (assume hyd. radius = depth of flow)

7. Surface description
8. Manning's roughness coeff., n
9. Paved or unpaved
10. Depth of flow, d (default values: d=.4 unpaved, d=.2 paved) ft.
11. Flow Length, L
12. Watercourse slope, s
13. Average velocity, $V = \frac{1.49}{n} (d^{2/3})(s^{1/2})$
14. $T_t = \frac{L}{3600 * V}$

Segment ID					
ft.					
ft./ft.					
fps.					
hr.		+			= 0.000

Channel flow

15. Channel Bottom width, b
16. Horizontal side slope component, z (z horiz:1 vert) ft.
17. Depth of flow, d
18. Cross sectional flow area, A (assume trapazoidal) ft.²
19. Wetted perimeter, P_w
20. Hydraulic Radius, $R = \frac{A}{P_w}$
21. Channel slope, s
22. Manning's roughness coeff., n
23. $V = \frac{1.49}{n} (R^{2/3})(s^{1/2})$
24. Flow length, L
25. $T_t = \frac{L}{3600 * V}$
26. Watershed or subarea T_c or T_t (add T_t in steps 6, 14 & 25)

Segment ID	C-D				
ft.	15" HDPE				
	--				
ft.	FULL				
ft. ²	1.23				
ft.	3.93				
ft.	0.31				
ft./ft.	0.01				
	0.012				
fps.	5.72				
ft.	345.0				
hr.	0.017				= 0.017
hr.					= 0.156

Time of Concentration (T_c) or Travel Time (T_t) Worksheet

Project: Wake Robin Inn Redevelopment
 Location: Salisbury, CT
 Circle one: Present Developed
 Circle one: T_c T_t

By: MCB
 Checked: TDR
 Watershed: PRWS-30
 Subwatershed: _____

Date: Rev. 12/9/24
 Date: 12/09/24

Sheet flow (applicable to T_c only)

1. Surface description (Table 3-1)
2. Manning's roughness coeff. for sheet flow, n (Table 3-1)
3. Flow Length, L (< 300ft)
4. Two-year 24-hr rainfall, P_2
5. Land slope, s
6. $T_t = \frac{0.007 (nL)^{0.8}}{P_2^{0.5} (s^{0.4})}$

Segment ID	A-B				
	WOODS				
	0.400				
ft.	100.0				
in.	3.08				
ft./ft.	0.070				
hr.	0.221	=			0.221

Shallow concentrated flow (assume hyd. radius = depth of flow)

7. Surface description
8. Manning's roughness coeff., n
9. Paved or unpaved
10. Depth of flow, d (default values: d=.4 unpaved, d=.2 paved) ft.
11. Flow Length, L
12. Watercourse slope, s
13. Average velocity, $V = \frac{1.49}{n} (d^{2/3})(s^{1/2})$
14. $T_t = \frac{L}{3600 * V}$

Segment ID	B-C				
	WOODS				
	0.100				
	UNPVD				
ft.	0.40				
ft./ft.	0.070				
fps.	2.14				
hr.	0.002				= 0.002

Channel flow

15. Channel Bottom width, b
16. Horizontal side slope component, z (z horiz:1 vert)
17. Depth of flow, d
18. Cross sectional flow area, A (assume trapazoidal) $ft.^2$
19. Wetted perimeter, P_w
20. Hydraulic Radius, $R = \frac{A}{P_w}$
21. Channel slope, s
22. Manning's roughness coeff., n
23. $V = \frac{1.49}{n} (R^{2/3})(s^{1/2})$
24. Flow length, L
25. $T_t = \frac{L}{3600 * V}$
26. Watershed or subarea T_c or T_t (add T_t in steps 6, 14 & 25)

Segment ID					
ft.					
ft.					
$ft.^2$					
ft.					
ft.					
ft./ft.					
fps.					
ft.					
hr.					= 0.000
hr.					0.223



POINT PRECIPITATION FREQUENCY ESTIMATES

Sanja Perica, Sandra Pavlovic, Michael St. Laurent, Carl Trypaluk, Dale Unruh, Orlan Wilhite

NOAA, National Weather Service, Silver Spring, Maryland

[PF tabular](#) | [PF graphical](#) | [Maps & aerials](#)

PF tabular

PDS-based point precipitation frequency estimates with 90% confidence intervals (in inches)¹										
Duration	Average recurrence interval (years)									
	1	2	5	10	25	50	100	200	500	1000
5-min	0.334 (0.255-0.437)	0.396 (0.303-0.518)	0.497 (0.379-0.653)	0.581 (0.441-0.768)	0.697 (0.513-0.960)	0.785 (0.567-1.10)	0.876 (0.614-1.27)	0.973 (0.652-1.45)	1.11 (0.717-1.72)	1.21 (0.769-1.92)
10-min	0.473 (0.362-0.618)	0.561 (0.429-0.734)	0.705 (0.538-0.926)	0.824 (0.624-1.09)	0.988 (0.726-1.36)	1.11 (0.802-1.56)	1.24 (0.870-1.80)	1.38 (0.924-2.06)	1.57 (1.02-2.43)	1.72 (1.09-2.72)
15-min	0.556 (0.426-0.728)	0.660 (0.504-0.864)	0.829 (0.631-1.09)	0.969 (0.734-1.28)	1.16 (0.854-1.60)	1.31 (0.943-1.84)	1.46 (1.02-2.12)	1.62 (1.09-2.42)	1.85 (1.20-2.86)	2.02 (1.28-3.20)
30-min	0.763 (0.584-0.999)	0.906 (0.693-1.19)	1.14 (0.869-1.50)	1.33 (1.01-1.76)	1.60 (1.18-2.21)	1.80 (1.30-2.54)	2.01 (1.42-2.94)	2.24 (1.50-3.36)	2.57 (1.66-3.98)	2.84 (1.80-4.48)
60-min	0.971 (0.743-1.27)	1.15 (0.882-1.51)	1.45 (1.11-1.91)	1.70 (1.29-2.25)	2.04 (1.50-2.82)	2.30 (1.66-3.24)	2.57 (1.81-3.75)	2.87 (1.92-4.29)	3.30 (2.13-5.11)	3.65 (2.31-5.77)
2-hr	1.28 (0.981-1.66)	1.48 (1.14-1.93)	1.82 (1.39-2.37)	2.09 (1.59-2.75)	2.47 (1.83-3.39)	2.76 (2.00-3.86)	3.06 (2.15-4.43)	3.38 (2.28-5.03)	3.82 (2.48-5.90)	4.17 (2.65-6.58)
3-hr	1.47 (1.13-1.90)	1.70 (1.31-2.21)	2.08 (1.60-2.71)	2.39 (1.83-3.14)	2.83 (2.09-3.86)	3.16 (2.29-4.40)	3.49 (2.47-5.05)	3.86 (2.60-5.74)	4.38 (2.85-6.74)	4.79 (3.05-7.54)
6-hr	1.80 (1.39-2.32)	2.12 (1.64-2.75)	2.66 (2.05-3.46)	3.11 (2.39-4.06)	3.73 (2.78-5.10)	4.18 (3.07-5.86)	4.68 (3.35-6.83)	5.26 (3.56-7.81)	6.14 (4.01-9.44)	6.89 (4.40-10.8)
12-hr	2.10 (1.64-2.70)	2.60 (2.02-3.35)	3.42 (2.65-4.42)	4.11 (3.16-5.33)	5.04 (3.80-6.93)	5.73 (4.25-8.08)	6.49 (4.73-9.61)	7.48 (5.06-11.1)	9.08 (5.93-13.9)	10.5 (6.71-16.4)
24-hr	2.41 (1.88-3.08)	3.08 (2.41-3.95)	4.19 (3.26-5.39)	5.11 (3.95-6.61)	6.37 (4.83-8.76)	7.28 (5.45-10.3)	8.32 (6.14-12.4)	9.71 (6.59-14.3)	12.0 (7.87-18.4)	14.1 (9.06-22.0)
2-day	2.75 (2.16-3.50)	3.54 (2.78-4.51)	4.83 (3.78-6.18)	5.91 (4.59-7.60)	7.38 (5.62-10.1)	8.45 (6.35-11.9)	9.66 (7.16-14.4)	11.3 (7.69-16.6)	14.0 (9.21-21.4)	16.5 (10.6-25.6)
3-day	3.00 (2.36-3.81)	3.85 (3.03-4.90)	5.24 (4.11-6.68)	6.39 (4.98-8.20)	7.98 (6.09-10.9)	9.12 (6.87-12.8)	10.4 (7.74-15.5)	12.2 (8.31-17.9)	15.1 (9.95-23.0)	17.8 (11.5-27.6)
4-day	3.22 (2.54-4.08)	4.12 (3.25-5.23)	5.58 (4.38-7.11)	6.80 (5.31-8.71)	8.47 (6.48-11.5)	9.68 (7.30-13.6)	11.0 (8.21-16.3)	12.9 (8.81-18.9)	16.0 (10.5-24.3)	18.8 (12.1-29.0)
7-day	3.84 (3.04-4.85)	4.84 (3.83-6.11)	6.46 (5.10-8.20)	7.82 (6.13-9.97)	9.68 (7.42-13.1)	11.0 (8.33-15.4)	12.5 (9.32-18.4)	14.6 (9.98-21.3)	17.9 (11.8-27.1)	20.8 (13.5-32.2)
10-day	4.48 (3.55-5.63)	5.52 (4.38-6.96)	7.24 (5.72-9.15)	8.66 (6.80-11.0)	10.6 (8.14-14.3)	12.0 (9.09-16.7)	13.6 (10.1-19.9)	15.7 (10.8-22.9)	19.1 (12.6-28.8)	22.0 (14.3-34.0)
20-day	6.52 (5.20-8.16)	7.61 (6.06-9.54)	9.40 (7.46-11.8)	10.9 (8.59-13.8)	12.9 (9.92-17.2)	14.4 (10.9-19.7)	16.1 (11.8-23.0)	18.1 (12.5-26.2)	21.2 (14.1-32.0)	23.9 (15.6-36.8)
30-day	8.23 (6.58-10.3)	9.34 (7.46-11.7)	11.2 (8.89-14.0)	12.7 (10.0-16.0)	14.8 (11.3-19.5)	16.3 (12.3-22.1)	18.0 (13.2-25.4)	19.9 (13.8-28.8)	22.7 (15.2-34.1)	25.1 (16.4-38.5)
45-day	10.3 (8.29-12.9)	11.5 (9.21-14.3)	13.4 (10.7-16.8)	15.0 (11.9-18.9)	17.2 (13.2-22.5)	18.8 (14.2-25.2)	20.5 (14.9-28.5)	22.3 (15.5-32.1)	24.7 (16.6-37.0)	26.6 (17.4-40.8)
60-day	12.1 (9.70-15.0)	13.3 (10.7-16.6)	15.3 (12.2-19.1)	17.0 (13.5-21.3)	19.3 (14.8-25.1)	21.1 (15.8-28.1)	22.8 (16.5-31.4)	24.5 (17.1-35.1)	26.6 (17.8-39.6)	28.0 (18.3-42.9)

¹ Precipitation frequency (PF) estimates in this table are based on frequency analysis of partial duration series (PDS). Numbers in parenthesis are PF estimates at lower and upper bounds of the 90% confidence interval. The probability that precipitation frequency estimates (for a given duration and average recurrence interval) will be greater than the upper bound (or less than the lower bound) is 5%. Estimates at upper bounds are not checked against probable maximum precipitation (PMP) estimates and may be higher than currently valid PMP values. Please refer to NOAA Atlas 14 document for more information.

[Back to Top](#)

PF graphical

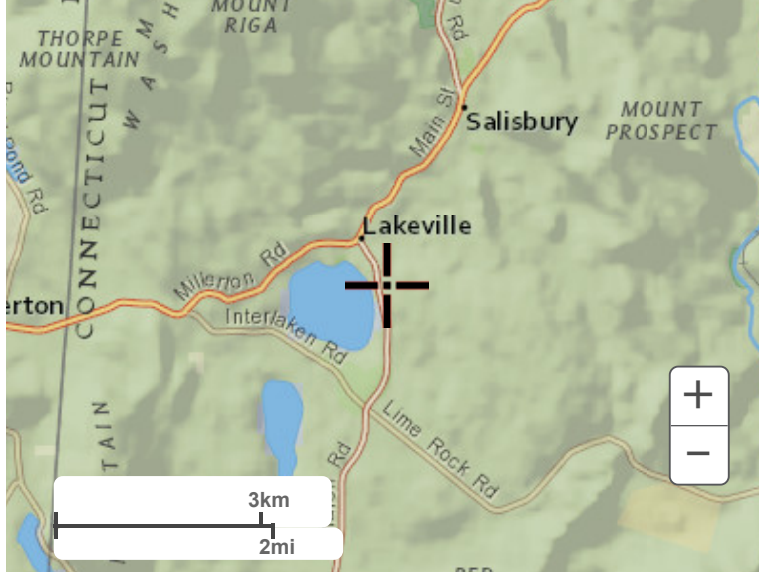

Large scale terrain



Large scale map

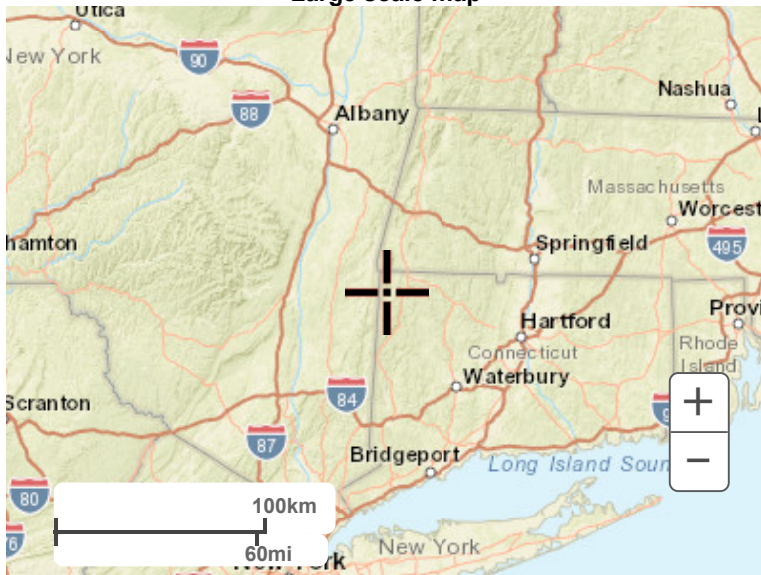

Large scale aerial

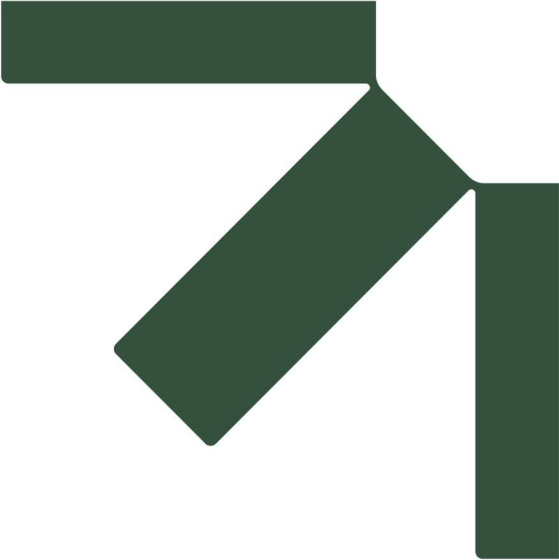

Appendix G

Hydrologic Analysis - Computer Model Results

Wake Robin Inn Redevelopment

104 & 106 Sharon Road, Salisbury, Connecticut

Drainage Report

Prepared for:
Aradev LLC
352 Atlantic Avenue, Unit 2
Brooklyn, NY 11217

SLR Project No.: 141.22100.00001

April 25, 2025

Revised July 28, 2025



Hydrographs Peak Flowrate Summary (cfs)
Existing vs. Proposed

<i>Storm Event</i>	1yr		2yr		5yr		10yr		25yr		50yr		100yr	
	Exist	Prop	Exist	Prop	Exist	Prop	Exist	Prop	Exist	Prop	Exist	Prop	Exist	Prop
Point of Analysis A	4.2	4.0	8.1	7.8	15.5	14.9	22.3	21.5	32.2	31.0	39.6	38.0	48.1	46.3
WQ Basin 140 W.S. Elev. (ft.) Top of Berm Elev. = 839.0	-	838.5	-	838.5	-	838.6	-	838.6	-	838.7	-	838.7	-	838.7
Point of Analysis B	3.9	2.0	6.1	3.1	10.1	8.1	13.5	13.0	18.2	17.9	21.6	20.5	25.5	23.5
DET 210 W.S. Elev. (ft.) Top of Berm Elev. = 818.2	-	815.6	-	815.9	-	816.1	-	816.2	-	816.6	-	816.8	-	817.1
DET 220 W.S. Elev. (ft.) Top of Berm Elev. = 804.0	-	802.1	-	802.4	-	802.7	-	802.9	-	802.9	-	803.0	-	803.0
Point of Analysis C	0.9	0.7	1.6	1.2	2.9	2.1	4.0	2.8	5.6	3.9	6.8	4.7	8.1	5.7

Study Area

- A
- B
- C

Description

- Wells Hill Road
- Sharon Road Storm Drainage
- Sharon Road and Southern Properties

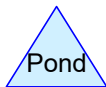
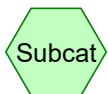
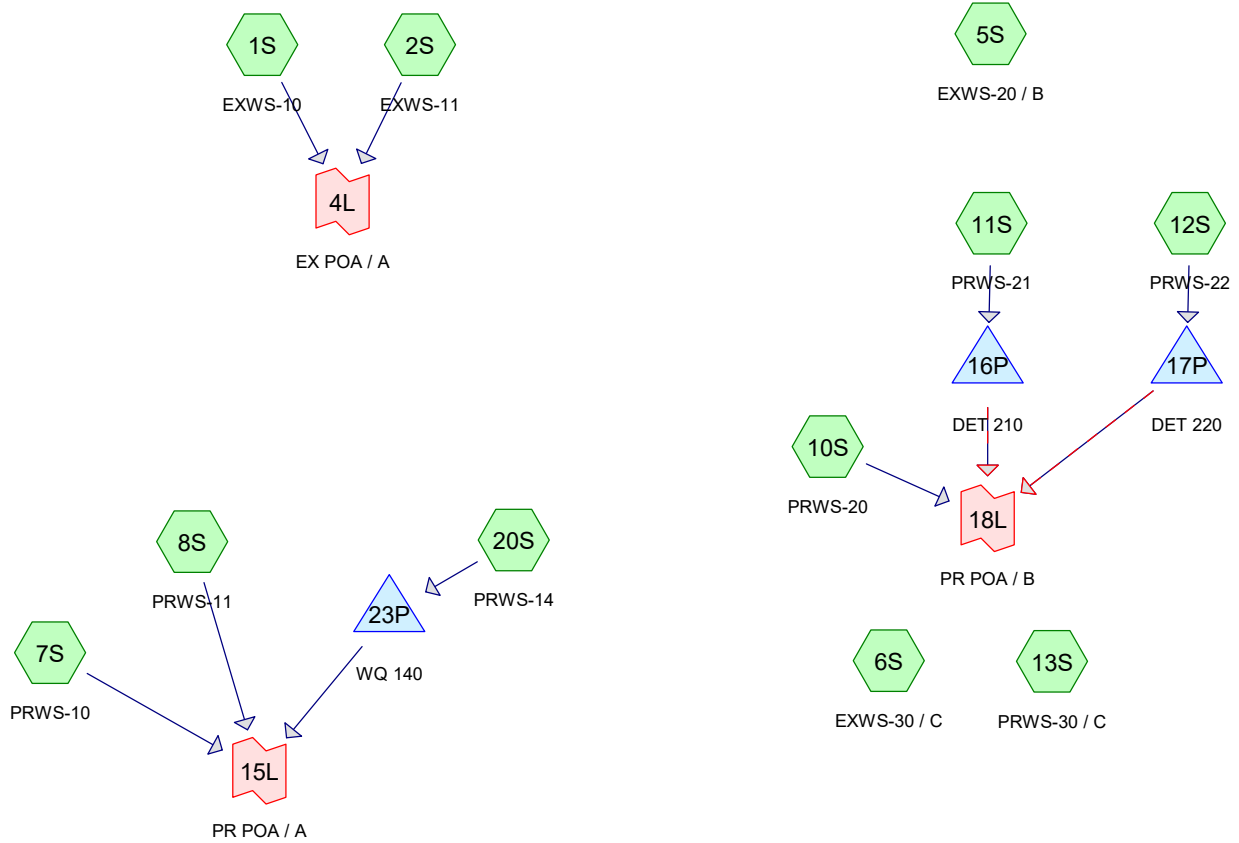

Routing Diagram for WR-Model06
 Prepared by SLR International Corporation, Printed 7/24/2025
 HydroCAD® 10.20-7a s/n 08105 © 2025 HydroCAD Software Solutions LLC

TABLE OF CONTENTS

Project Reports

- 1 Routing Diagram

1-Year Event

- 2 Subcat 1S: EXWS-10
- 3 Subcat 2S: EXWS-11
- 4 Subcat 5S: EXWS-20 / B
- 5 Subcat 6S: EXWS-30 / C
- 6 Subcat 7S: PRWS-10
- 7 Subcat 8S: PRWS-11
- 8 Subcat 10S: PRWS-20
- 9 Subcat 11S: PRWS-21
- 10 Subcat 12S: PRWS-22
- 11 Subcat 13S: PRWS-30 / C
- 12 Subcat 20S: PRWS-14
- 13 Pond 16P: DET 210
- 15 Pond 17P: DET 220
- 17 Pond 23P: WQ 140
- 19 Link 4L: EX POA / A
- 20 Link 15L: PR POA / A
- 21 Link 18L: PR POA / B

2-Year Event

- 22 Subcat 1S: EXWS-10
- 23 Subcat 2S: EXWS-11
- 24 Subcat 5S: EXWS-20 / B
- 25 Subcat 6S: EXWS-30 / C
- 26 Subcat 7S: PRWS-10
- 27 Subcat 8S: PRWS-11
- 28 Subcat 10S: PRWS-20
- 29 Subcat 11S: PRWS-21
- 30 Subcat 12S: PRWS-22
- 31 Subcat 13S: PRWS-30 / C
- 32 Subcat 20S: PRWS-14
- 33 Pond 16P: DET 210
- 35 Pond 17P: DET 220
- 37 Pond 23P: WQ 140
- 39 Link 4L: EX POA / A
- 40 Link 15L: PR POA / A
- 41 Link 18L: PR POA / B

5-Year Event

- 42 Subcat 1S: EXWS-10
- 43 Subcat 2S: EXWS-11
- 44 Subcat 5S: EXWS-20 / B
- 45 Subcat 6S: EXWS-30 / C

WR-Model06

Prepared by SLR International Corporation
HydroCAD® 10.20-7a s/n 08105 © 2025 HydroCAD Software Solutions LLC

Table of Contents

Printed 7/24/2025

- 46 Subcat 7S: PRWS-10
- 47 Subcat 8S: PRWS-11
- 48 Subcat 10S: PRWS-20
- 49 Subcat 11S: PRWS-21
- 50 Subcat 12S: PRWS-22
- 51 Subcat 13S: PRWS-30 / C
- 52 Subcat 20S: PRWS-14
- 53 Pond 16P: DET 210
- 55 Pond 17P: DET 220
- 57 Pond 23P: WQ 140
- 59 Link 4L: EX POA / A
- 60 Link 15L: PR POA / A
- 61 Link 18L: PR POA / B

10-Year Event

- 62 Subcat 1S: EXWS-10
- 63 Subcat 2S: EXWS-11
- 64 Subcat 5S: EXWS-20 / B
- 65 Subcat 6S: EXWS-30 / C
- 66 Subcat 7S: PRWS-10
- 67 Subcat 8S: PRWS-11
- 68 Subcat 10S: PRWS-20
- 69 Subcat 11S: PRWS-21
- 70 Subcat 12S: PRWS-22
- 71 Subcat 13S: PRWS-30 / C
- 72 Subcat 20S: PRWS-14
- 73 Pond 16P: DET 210
- 75 Pond 17P: DET 220
- 77 Pond 23P: WQ 140
- 79 Link 4L: EX POA / A
- 80 Link 15L: PR POA / A
- 81 Link 18L: PR POA / B

25-Year Event

- 82 Subcat 1S: EXWS-10
- 83 Subcat 2S: EXWS-11
- 84 Subcat 5S: EXWS-20 / B
- 85 Subcat 6S: EXWS-30 / C
- 86 Subcat 7S: PRWS-10
- 87 Subcat 8S: PRWS-11
- 88 Subcat 10S: PRWS-20
- 89 Subcat 11S: PRWS-21
- 90 Subcat 12S: PRWS-22
- 91 Subcat 13S: PRWS-30 / C
- 92 Subcat 20S: PRWS-14
- 93 Pond 16P: DET 210
- 95 Pond 17P: DET 220
- 97 Pond 23P: WQ 140

WR-Model06

Prepared by SLR International Corporation

HydroCAD® 10.20-7a s/n 08105 © 2025 HydroCAD Software Solutions LLC

Table of Contents

Printed 7/24/2025

- 99 Link 4L: EX POA / A
- 100 Link 15L: PR POA / A
- 101 Link 18L: PR POA / B

50-Year Event

- 102 Subcat 1S: EXWS-10
- 103 Subcat 2S: EXWS-11
- 104 Subcat 5S: EXWS-20 / B
- 105 Subcat 6S: EXWS-30 / C
- 106 Subcat 7S: PRWS-10
- 107 Subcat 8S: PRWS-11
- 108 Subcat 10S: PRWS-20
- 109 Subcat 11S: PRWS-21
- 110 Subcat 12S: PRWS-22
- 111 Subcat 13S: PRWS-30 / C
- 112 Subcat 20S: PRWS-14
- 113 Pond 16P: DET 210
- 115 Pond 17P: DET 220
- 117 Pond 23P: WQ 140
- 119 Link 4L: EX POA / A
- 120 Link 15L: PR POA / A
- 121 Link 18L: PR POA / B

100-Year Event

- 122 Subcat 1S: EXWS-10
- 123 Subcat 2S: EXWS-11
- 124 Subcat 5S: EXWS-20 / B
- 125 Subcat 6S: EXWS-30 / C
- 126 Subcat 7S: PRWS-10
- 127 Subcat 8S: PRWS-11
- 128 Subcat 10S: PRWS-20
- 129 Subcat 11S: PRWS-21
- 130 Subcat 12S: PRWS-22
- 131 Subcat 13S: PRWS-30 / C
- 132 Subcat 20S: PRWS-14
- 133 Pond 16P: DET 210
- 135 Pond 17P: DET 220
- 137 Pond 23P: WQ 140
- 139 Link 4L: EX POA / A
- 140 Link 15L: PR POA / A
- 141 Link 18L: PR POA / B

Summary for Subcatchment 1S: EXWS-10

Runoff = 1.25 cfs @ 12.24 hrs, Volume= 0.115 af, Depth> 0.56"
Routed to Link 4L : EX POA / A

Runoff by SCS TR-20 method, UH=SCS, Weighted-CN, Time Span= 5.00-20.00 hrs, dt= 0.05 hrs
NOAA 24-hr D 1-Year Rainfall=2.41"

Area (ac)	CN	Description
* 2.460	76	
2.460		100.00% Pervious Area

Tc (min)	Length (feet)	Slope (ft/ft)	Velocity (ft/sec)	Capacity (cfs)	Description
14.2					Direct Entry,

Subcatchment 1S: EXWS-10

Hydrograph

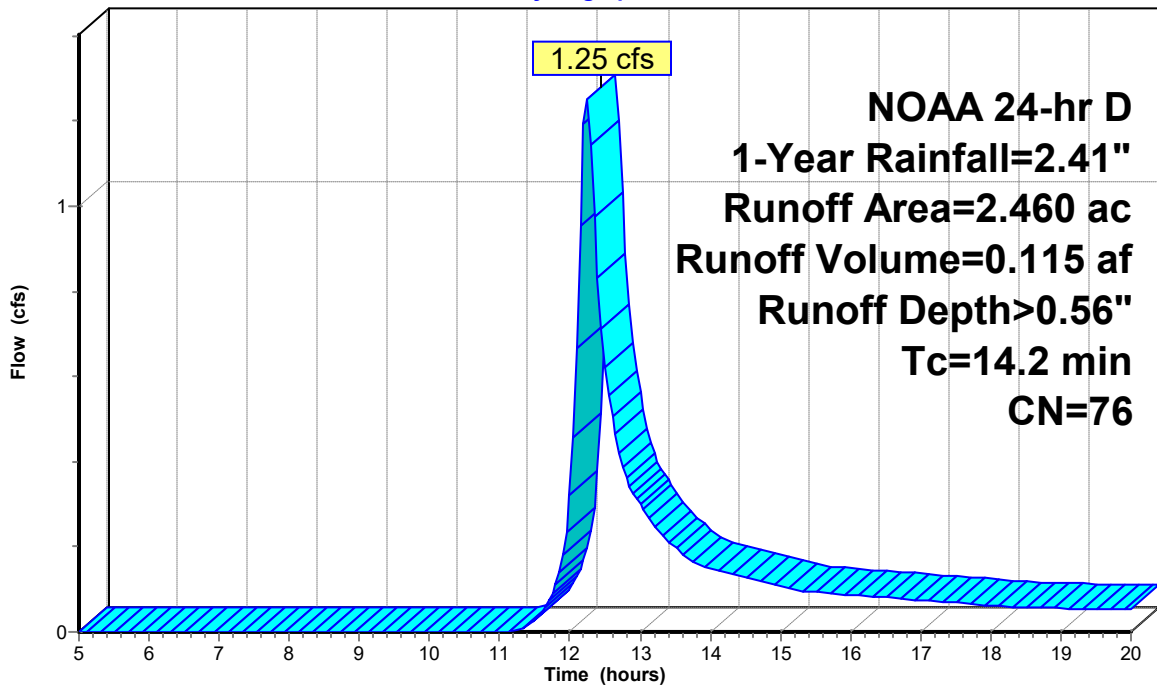

Summary for Subcatchment 2S: EXWS-11

Runoff = 3.72 cfs @ 12.63 hrs, Volume= 0.593 af, Depth> 0.44"
Routed to Link 4L : EX POA / A

Runoff by SCS TR-20 method, UH=SCS, Weighted-CN, Time Span= 5.00-20.00 hrs, dt= 0.05 hrs
NOAA 24-hr D 1-Year Rainfall=2.41"

Table with 3 columns: Area (ac), CN, Description. Row 1: 16.050, 73, 100.00% Pervious Area

Table with 7 columns: Tc (min), Length (feet), Slope (ft/ft), Velocity (ft/sec), Capacity (cfs), Description. Row 1: 39.6, Direct Entry,

Subcatchment 2S: EXWS-11

Hydrograph

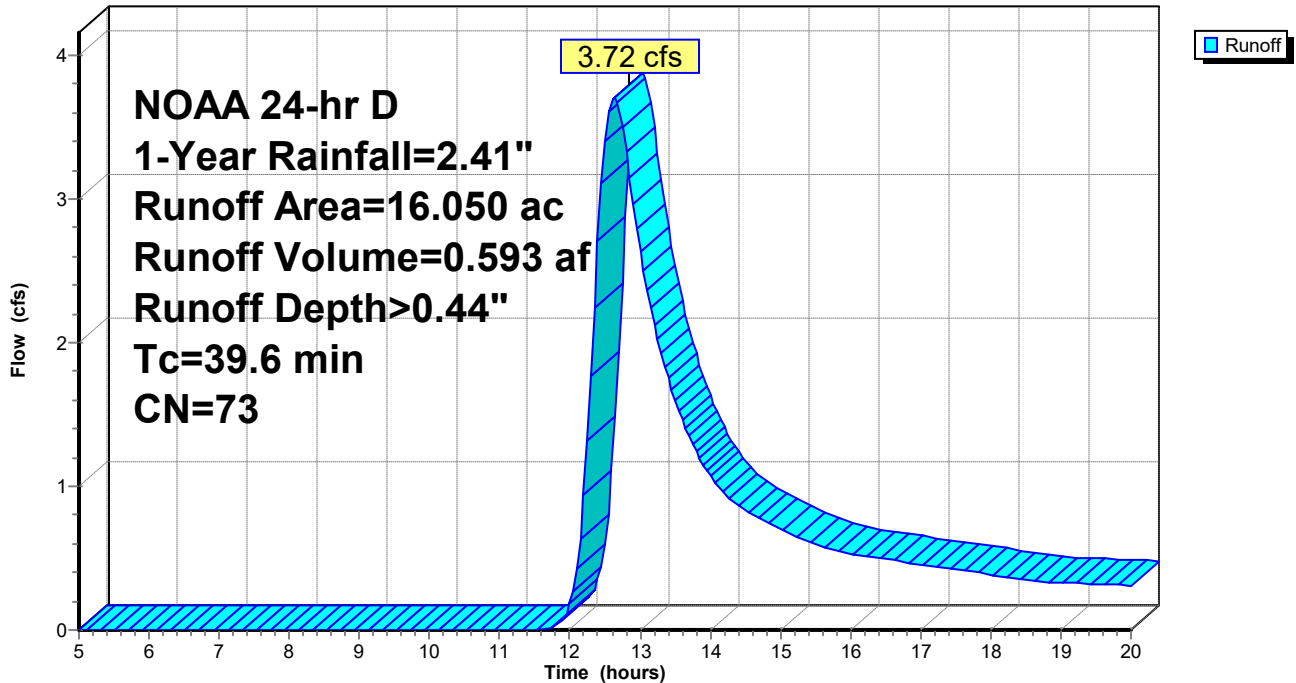

Summary for Subcatchment 5S: EXWS-20 / B

Runoff = 3.91 cfs @ 12.24 hrs, Volume= 0.349 af, Depth> 0.84"

Runoff by SCS TR-20 method, UH=SCS, Weighted-CN, Time Span= 5.00-20.00 hrs, dt= 0.05 hrs
NOAA 24-hr D 1-Year Rainfall=2.41"

Area (ac)	CN	Description
* 5.000	82	
5.000		100.00% Pervious Area

Tc (min)	Length (feet)	Slope (ft/ft)	Velocity (ft/sec)	Capacity (cfs)	Description
14.9					Direct Entry,

Subcatchment 5S: EXWS-20 / B

Hydrograph

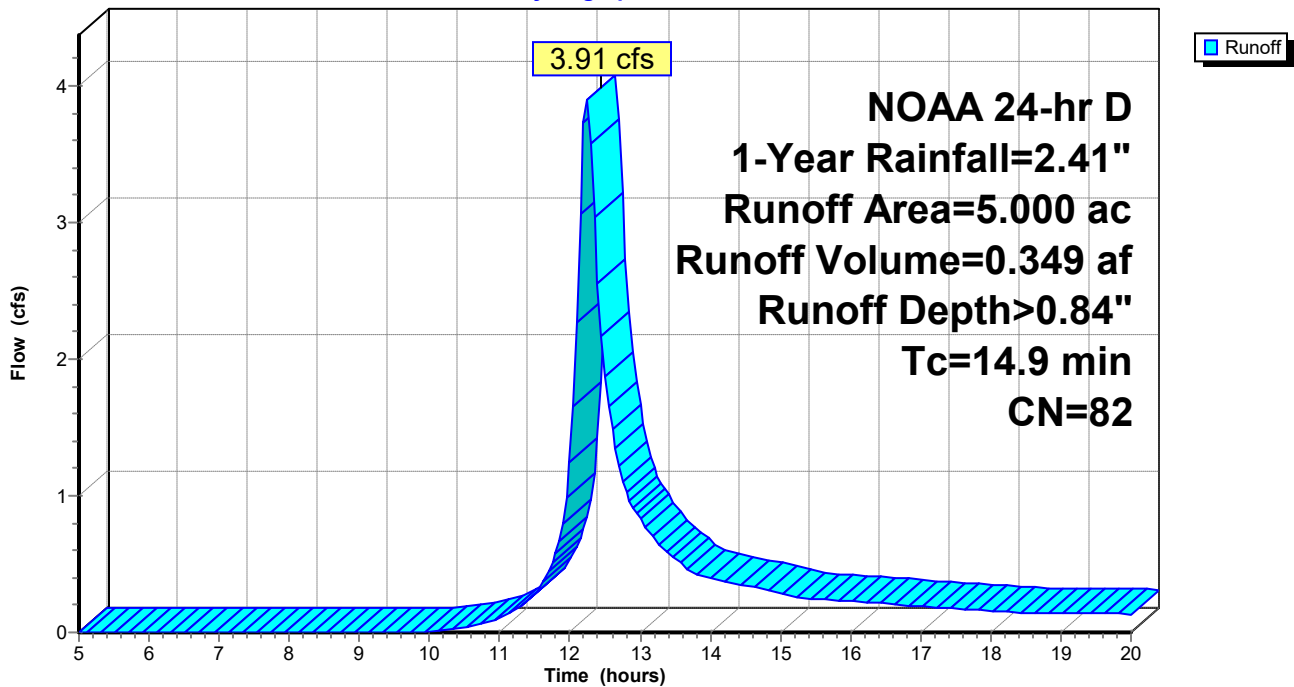

Summary for Subcatchment 6S: EXWS-30 / C

Runoff = 0.93 cfs @ 12.24 hrs, Volume= 0.084 af, Depth> 0.60"

Runoff by SCS TR-20 method, UH=SCS, Weighted-CN, Time Span= 5.00-20.00 hrs, dt= 0.05 hrs
NOAA 24-hr D 1-Year Rainfall=2.41"

Area (ac)	CN	Description
* 1.670	77	
1.670		100.00% Pervious Area

Tc (min)	Length (feet)	Slope (ft/ft)	Velocity (ft/sec)	Capacity (cfs)	Description
14.0					Direct Entry,

Subcatchment 6S: EXWS-30 / C

Hydrograph

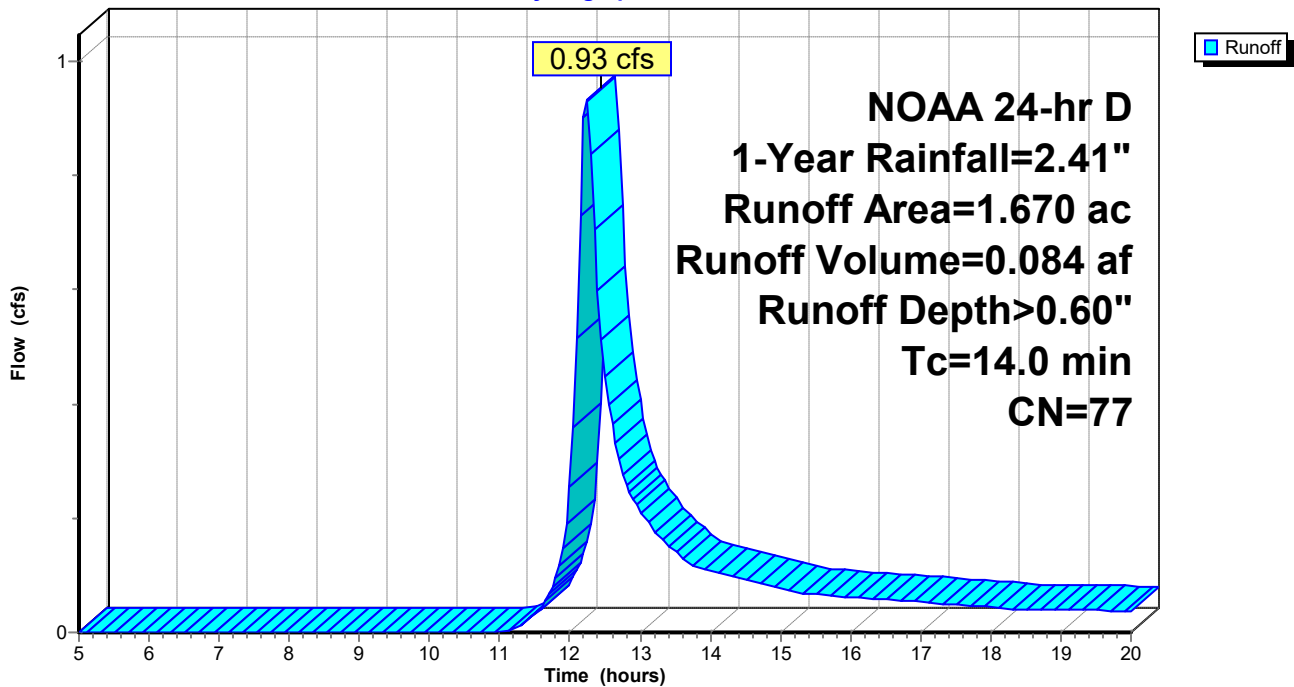

Summary for Subcatchment 7S: PRWS-10

Runoff = 1.19 cfs @ 12.16 hrs, Volume= 0.087 af, Depth> 0.65"
Routed to Link 15L : PR POA / A

Runoff by SCS TR-20 method, UH=SCS, Weighted-CN, Time Span= 5.00-20.00 hrs, dt= 0.05 hrs
NOAA 24-hr D 1-Year Rainfall=2.41"

Area (ac)	CN	Description
* 1.600	78	
1.600		100.00% Pervious Area

Tc (min)	Length (feet)	Slope (ft/ft)	Velocity (ft/sec)	Capacity (cfs)	Description
8.2					Direct Entry,

Subcatchment 7S: PRWS-10

Hydrograph

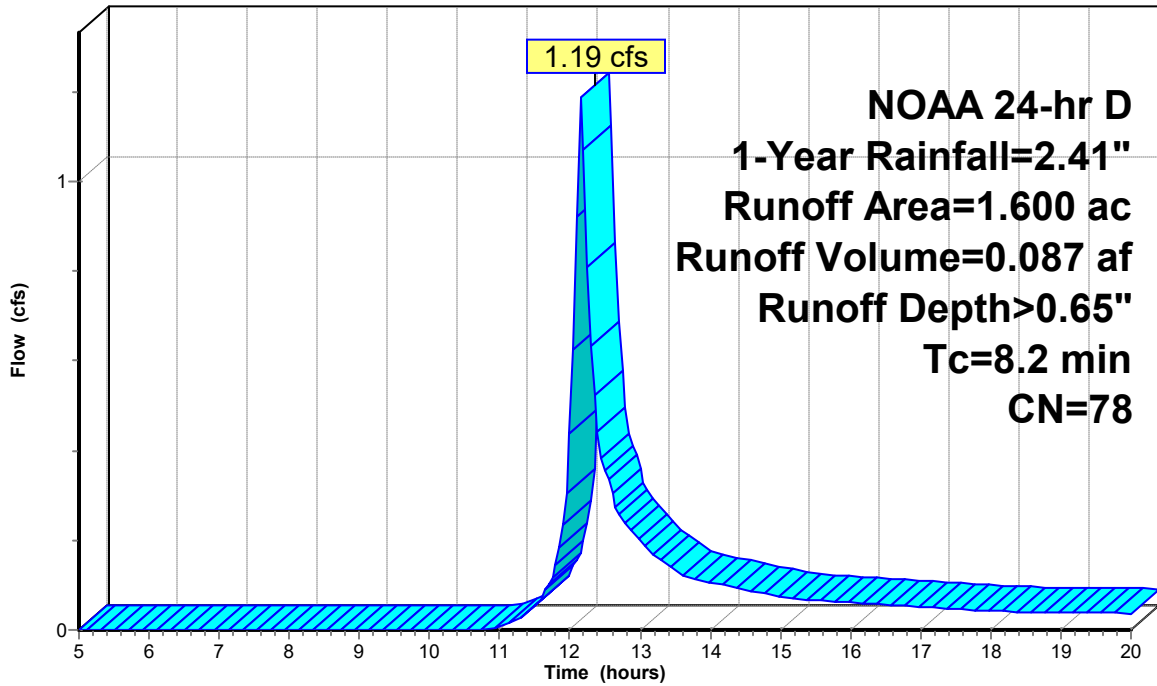

**NOAA 24-hr D
1-Year Rainfall=2.41"
Runoff Area=1.600 ac
Runoff Volume=0.087 af
Runoff Depth>0.65"
Tc=8.2 min
CN=78**

Summary for Subcatchment 8S: PRWS-11

Runoff = 3.69 cfs @ 12.62 hrs, Volume= 0.588 af, Depth> 0.44"
Routed to Link 15L : PR POA / A

Runoff by SCS TR-20 method, UH=SCS, Weighted-CN, Time Span= 5.00-20.00 hrs, dt= 0.05 hrs
NOAA 24-hr D 1-Year Rainfall=2.41"

Area (ac)	CN	Description
* 15.920	73	
15.920		100.00% Pervious Area

Tc (min)	Length (feet)	Slope (ft/ft)	Velocity (ft/sec)	Capacity (cfs)	Description
39.5					Direct Entry,

Subcatchment 8S: PRWS-11

Hydrograph

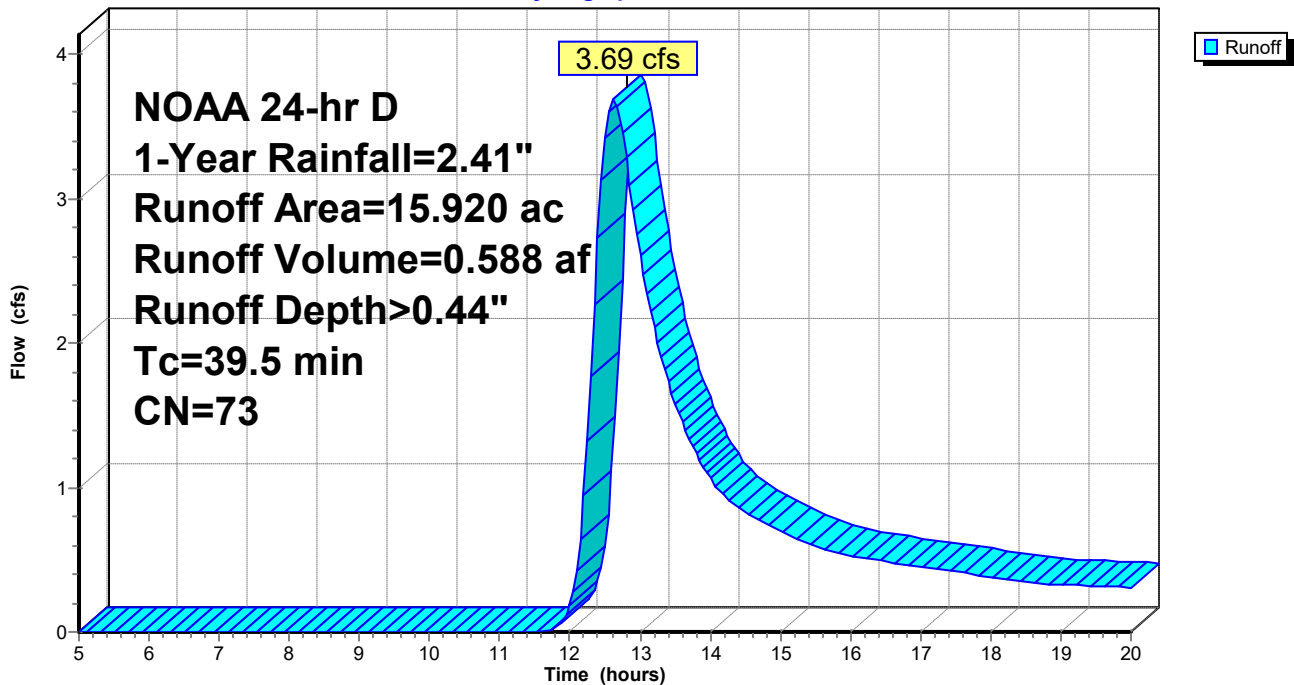

Summary for Subcatchment 10S: PRWS-20

Runoff = 1.96 cfs @ 12.25 hrs, Volume= 0.180 af, Depth> 0.84"
Routed to Link 18L : PR POA / B

Runoff by SCS TR-20 method, UH=SCS, Weighted-CN, Time Span= 5.00-20.00 hrs, dt= 0.05 hrs
NOAA 24-hr D 1-Year Rainfall=2.41"

Table with 3 columns: Area (ac), CN, Description. Row 1: 2.580, 82, 100.00% Pervious Area

Table with 7 columns: Tc (min), Length (feet), Slope (ft/ft), Velocity (ft/sec), Capacity (cfs), Description. Row 1: 15.9, Direct Entry,

Subcatchment 10S: PRWS-20

Hydrograph

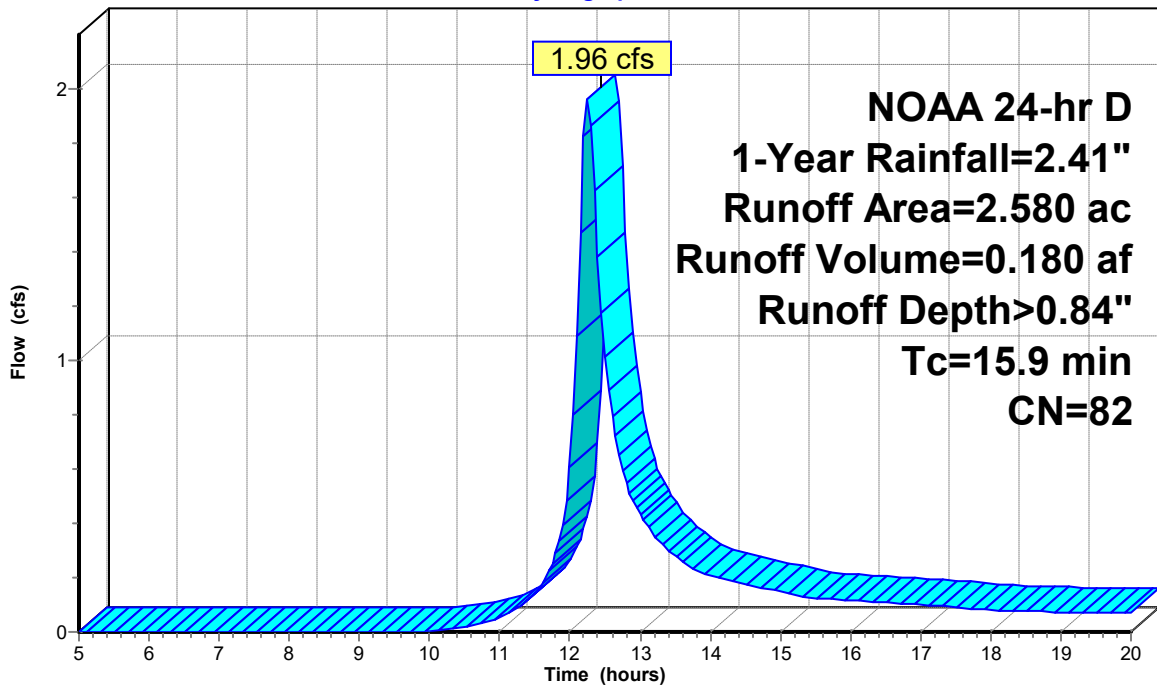

Runoff

Summary for Subcatchment 11S: PRWS-21

Runoff = 3.95 cfs @ 12.17 hrs, Volume= 0.299 af, Depth> 1.26"
Routed to Pond 16P : DET 210

Runoff by SCS TR-20 method, UH=SCS, Weighted-CN, Time Span= 5.00-20.00 hrs, dt= 0.05 hrs
NOAA 24-hr D 1-Year Rainfall=2.41"

Area (ac)	CN	Description
* 2.840	89	
2.840		100.00% Pervious Area

Tc (min)	Length (feet)	Slope (ft/ft)	Velocity (ft/sec)	Capacity (cfs)	Description
9.4					Direct Entry,

Subcatchment 11S: PRWS-21

Hydrograph

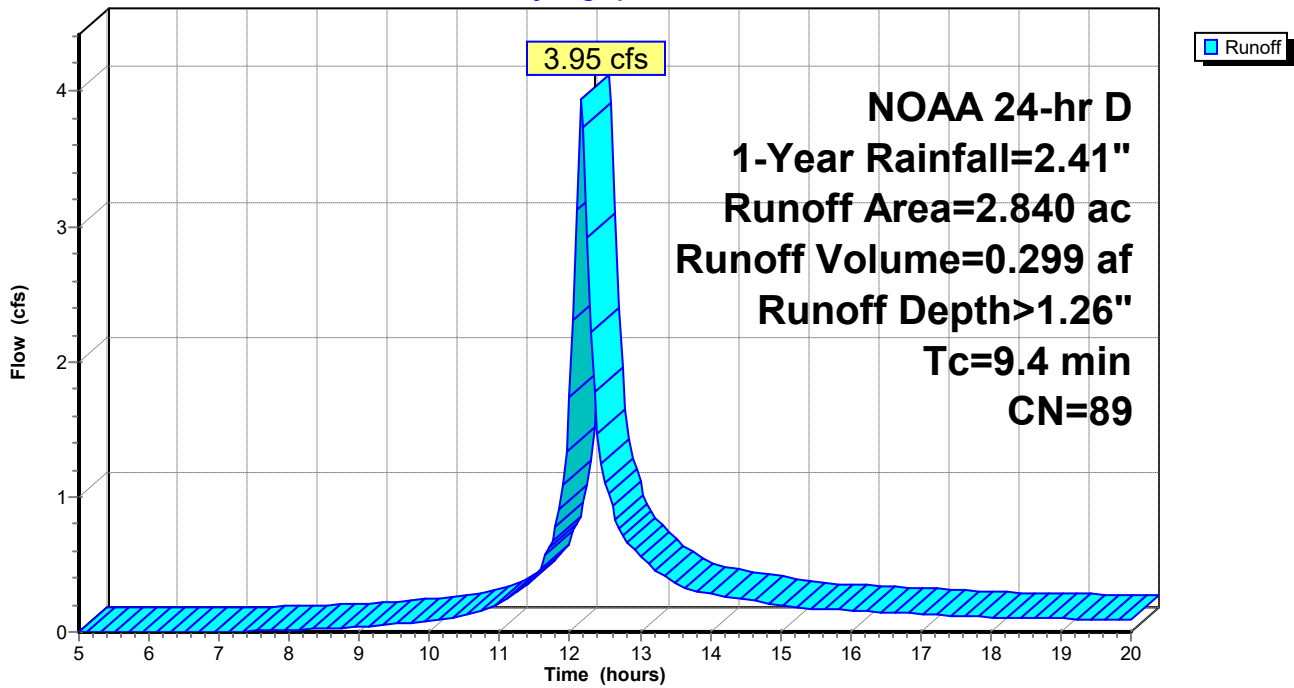

Summary for Subcatchment 12S: PRWS-22

Runoff = 1.10 cfs @ 12.17 hrs, Volume= 0.085 af, Depth> 1.34"
 Routed to Pond 17P : DET 220

Runoff by SCS TR-20 method, UH=SCS, Weighted-CN, Time Span= 5.00-20.00 hrs, dt= 0.05 hrs
 NOAA 24-hr D 1-Year Rainfall=2.41"

Area (ac)	CN	Description
* 0.760	90	
0.760		100.00% Pervious Area

Tc (min)	Length (feet)	Slope (ft/ft)	Velocity (ft/sec)	Capacity (cfs)	Description
9.7					Direct Entry,

Subcatchment 12S: PRWS-22

Hydrograph

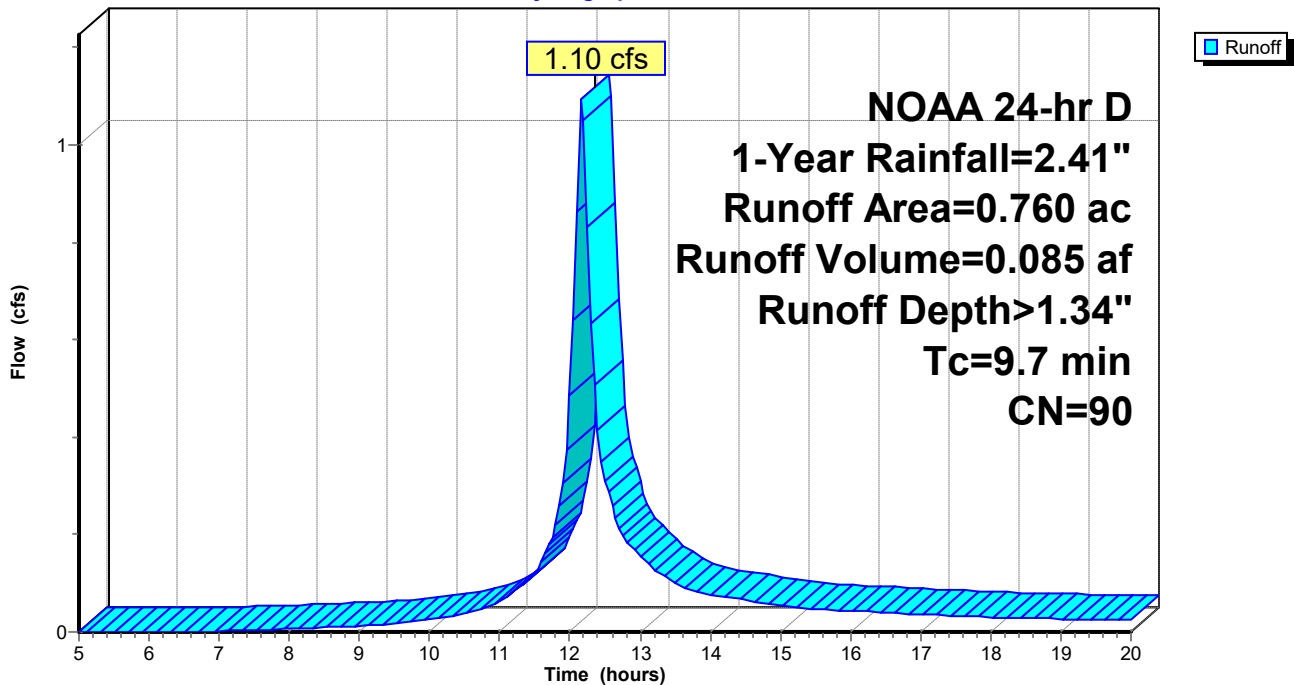

Summary for Subcatchment 13S: PRWS-30 / C

Runoff = 0.69 cfs @ 12.23 hrs, Volume= 0.061 af, Depth> 0.65"

Runoff by SCS TR-20 method, UH=SCS, Weighted-CN, Time Span= 5.00-20.00 hrs, dt= 0.05 hrs
NOAA 24-hr D 1-Year Rainfall=2.41"

Area (ac)	CN	Description
* 1.130	78	
1.130		100.00% Pervious Area

Tc (min)	Length (feet)	Slope (ft/ft)	Velocity (ft/sec)	Capacity (cfs)	Description
13.4					Direct Entry,

Subcatchment 13S: PRWS-30 / C

Hydrograph

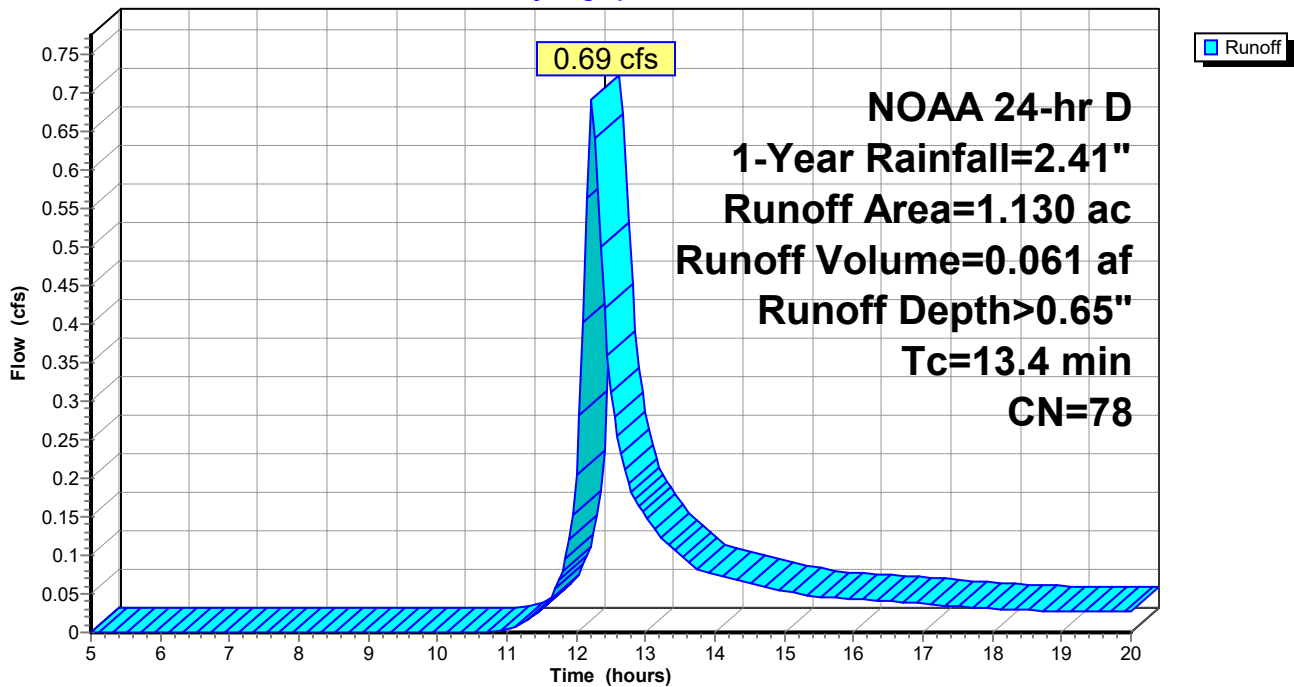

Summary for Subcatchment 20S: PRWS-14

Runoff = 0.40 cfs @ 12.15 hrs, Volume= 0.028 af, Depth> 1.01"
Routed to Pond 23P : WQ 140

Runoff by SCS TR-20 method, UH=SCS, Weighted-CN, Time Span= 5.00-20.00 hrs, dt= 0.05 hrs
NOAA 24-hr D 1-Year Rainfall=2.41"

Table with 3 columns: Area (ac), CN, Description. Row 1: 0.330, 85. Row 2: 0.330, 100.00% Pervious Area.

Table with 6 columns: Tc (min), Length (feet), Slope (ft/ft), Velocity (ft/sec), Capacity (cfs), Description. Row 1: 7.7, Direct Entry,

Subcatchment 20S: PRWS-14

Hydrograph

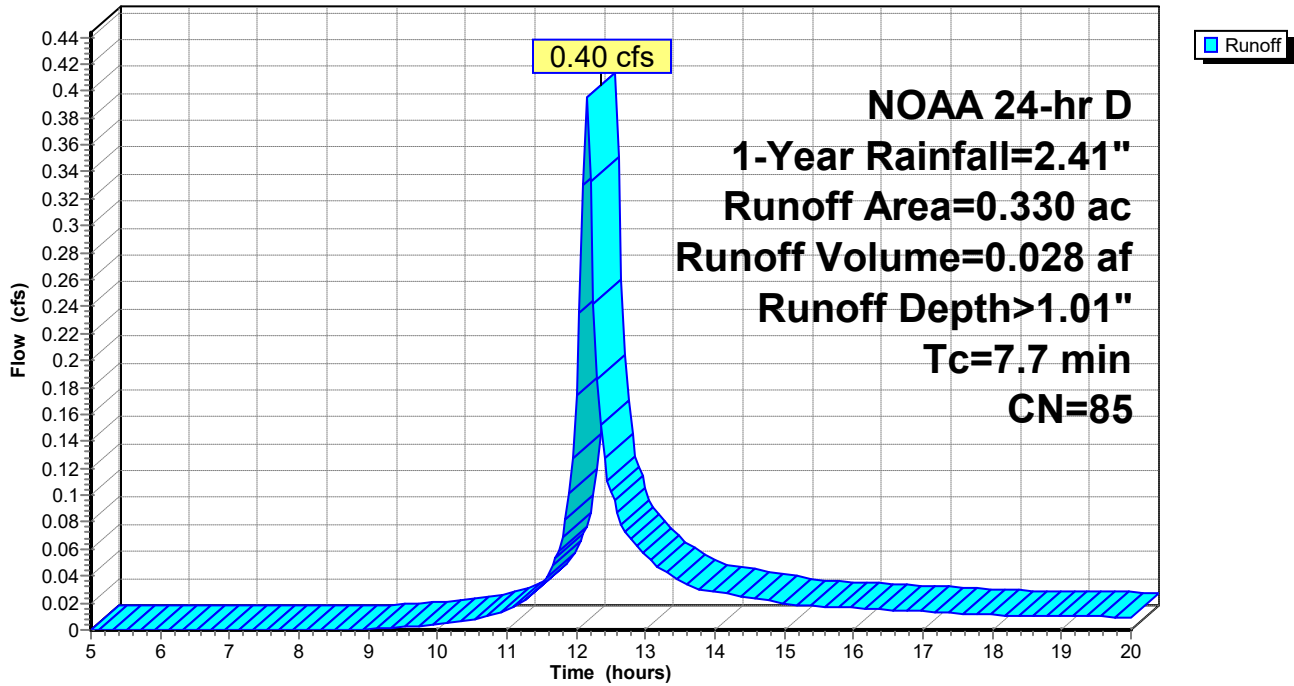

Summary for Pond 16P: DET 210

Inflow Area = 2.840 ac, 0.00% Impervious, Inflow Depth > 1.26" for 1-Year event
 Inflow = 3.95 cfs @ 12.17 hrs, Volume= 0.299 af
 Outflow = 0.58 cfs @ 12.98 hrs, Volume= 0.298 af, Atten= 85%, Lag= 48.8 min
 Discarded = 0.58 cfs @ 12.98 hrs, Volume= 0.298 af
 Primary = 0.00 cfs @ 5.00 hrs, Volume= 0.000 af
 Routed to Link 18L : PR POA / B
 Secondary = 0.00 cfs @ 5.00 hrs, Volume= 0.000 af
 Routed to Link 18L : PR POA / B

Routing by Stor-Ind method, Time Span= 5.00-20.00 hrs, dt= 0.05 hrs
 Peak Elev= 815.55' @ 12.98 hrs Surf.Area= 8,336 sf Storage= 4,376 cf

Plug-Flow detention time= 62.3 min calculated for 0.297 af (99% of inflow)
 Center-of-Mass det. time= 60.9 min (852.9 - 792.0)

Volume	Invert	Avail.Storage	Storage Description	
#1	815.00'	28,886 cf	Custom Stage Data (Conic) Listed below (Recalc)	
Elevation (feet)	Surf.Area (sq-ft)	Inc.Store (cubic-feet)	Cum.Store (cubic-feet)	Wet.Area (sq-ft)
815.00	7,672	0	0	7,672
816.00	8,907	8,282	8,282	8,948
817.00	10,296	9,593	17,875	10,380
818.00	11,741	11,011	28,886	11,872

Device	Routing	Invert	Outlet Devices
#1	Discarded	815.00'	3.000 in/hr Exfiltration over Surface area
#2	Primary	814.50'	15.0" Round Culvert L= 127.0' CPP, projecting, no headwall, Ke= 0.900 Inlet / Outlet Invert= 814.50' / 806.40' S= 0.0638 '/' Cc= 0.900 n= 0.012, Flow Area= 1.23 sf
#3	Device 2	815.90'	14.0' long Sharp-Crested Rectangular Weir 2 End Contraction(s)
#4	Secondary	817.20'	10.0' long + 3.0 ' SideZ x 8.0' breadth Broad-Crested Rectangular Weir Head (feet) 0.20 0.40 0.60 0.80 1.00 1.20 1.40 1.60 1.80 2.00 2.50 3.00 3.50 4.00 4.50 5.00 5.50 Coef. (English) 2.43 2.54 2.70 2.69 2.68 2.68 2.66 2.64 2.64 2.64 2.65 2.65 2.66 2.66 2.68 2.70 2.74

Discarded OutFlow Max=0.58 cfs @ 12.98 hrs HW=815.55' (Free Discharge)
 ↑1=Exfiltration (Exfiltration Controls 0.58 cfs)

Primary OutFlow Max=0.00 cfs @ 5.00 hrs HW=815.00' (Free Discharge)
 ↑2=Culvert (Passes 0.00 cfs of 0.87 cfs potential flow)
 ↑3=Sharp-Crested Rectangular Weir (Controls 0.00 cfs)

Secondary OutFlow Max=0.00 cfs @ 5.00 hrs HW=815.00' (Free Discharge)
 ↑4=Broad-Crested Rectangular Weir (Controls 0.00 cfs)

Pond 16P: DET 210

Hydrograph

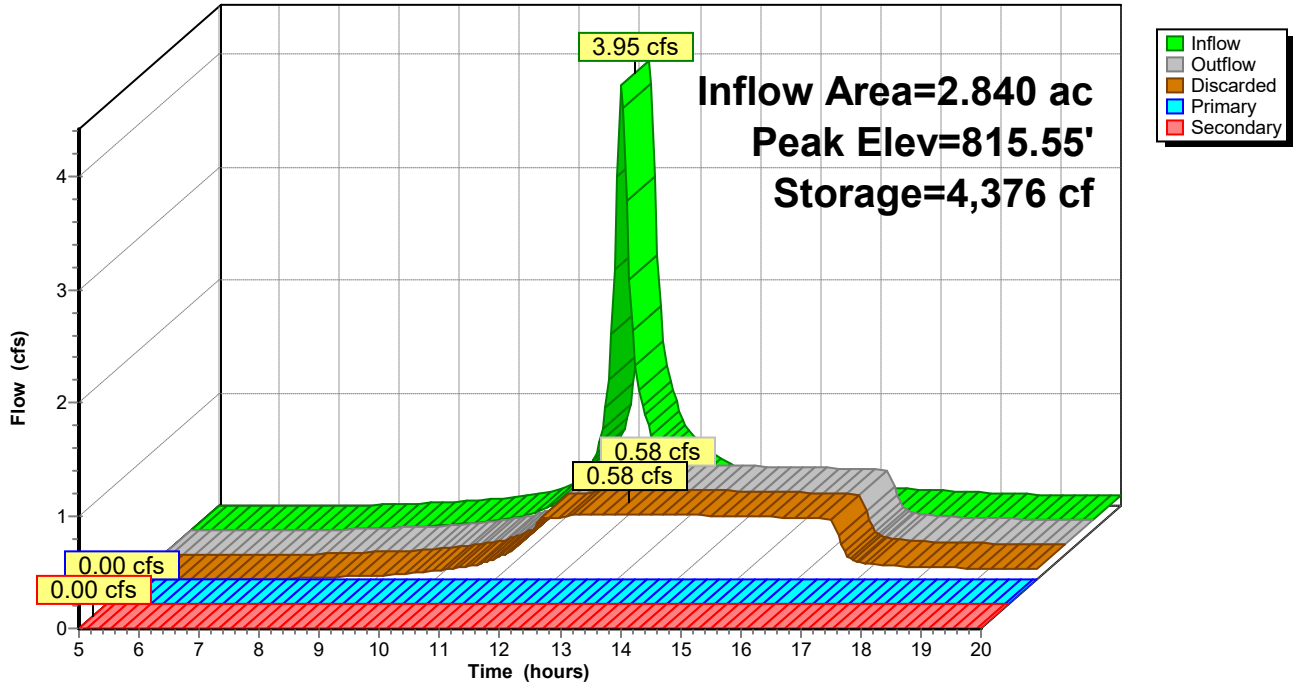

Summary for Pond 17P: DET 220

Inflow Area = 0.760 ac, 0.00% Impervious, Inflow Depth > 1.34" for 1-Year event
 Inflow = 1.10 cfs @ 12.17 hrs, Volume= 0.085 af
 Outflow = 0.08 cfs @ 14.05 hrs, Volume= 0.058 af, Atten= 93%, Lag= 112.7 min
 Discarded = 0.08 cfs @ 14.05 hrs, Volume= 0.058 af
 Primary = 0.00 cfs @ 5.00 hrs, Volume= 0.000 af
 Routed to Link 18L : PR POA / B
 Secondary = 0.00 cfs @ 5.00 hrs, Volume= 0.000 af
 Routed to Link 18L : PR POA / B

Routing by Stor-Ind method, Time Span= 5.00-20.00 hrs, dt= 0.05 hrs
 Peak Elev= 802.07' @ 14.05 hrs Surf.Area= 2,091 sf Storage= 1,877 cf

Plug-Flow detention time= 188.4 min calculated for 0.058 af (68% of inflow)
 Center-of-Mass det. time= 117.5 min (905.7 - 788.2)

Volume	Invert	Avail.Storage	Storage Description		
#1	801.00'	7,722 cf	Custom Stage Data (Conic) Listed below (Recalc)		
Elevation (feet)	Surf.Area (sq-ft)	Inc.Store (cubic-feet)	Cum.Store (cubic-feet)	Wet.Area (sq-ft)	
801.00	1,433	0	0	1,433	
802.00	2,039	1,727	1,727	2,057	
803.00	2,810	2,414	4,141	2,847	
804.00	4,412	3,581	7,722	4,463	

Device	Routing	Invert	Outlet Devices	
#1	Discarded	801.00'	1.580 in/hr Exfiltration over Surface area	
#2	Primary	800.50'	15.0" Round Culvert L= 39.0' CPP, projecting, no headwall, Ke= 0.900 Inlet / Outlet Invert= 800.50' / 800.00' S= 0.0128 '/' Cc= 0.900 n= 0.012, Flow Area= 1.23 sf	
#3	Device 2	802.20'	6.0" Vert. Orifice/Grate C= 0.600 Limited to weir flow at low heads	
#4	Device 2	802.80'	14.0' long Sharp-Crested Rectangular Weir 2 End Contraction(s)	
#5	Secondary	803.00'	10.0' long + 3.0 ' SideZ x 8.0' breadth Broad-Crested Rectangular Weir Head (feet) 0.20 0.40 0.60 0.80 1.00 1.20 1.40 1.60 1.80 2.00 2.50 3.00 3.50 4.00 4.50 5.00 5.50 Coef. (English) 2.43 2.54 2.70 2.69 2.68 2.68 2.66 2.64 2.64 2.64 2.65 2.65 2.66 2.66 2.68 2.70 2.74	

Discarded OutFlow Max=0.08 cfs @ 14.05 hrs HW=802.07' (Free Discharge)
 ↑1=Exfiltration (Exfiltration Controls 0.08 cfs)

Primary OutFlow Max=0.00 cfs @ 5.00 hrs HW=801.00' (Free Discharge)
 ↑2=Culvert (Passes 0.00 cfs of 0.87 cfs potential flow)
 ↑3=Orifice/Grate (Controls 0.00 cfs)
 ↑4=Sharp-Crested Rectangular Weir (Controls 0.00 cfs)

Secondary OutFlow Max=0.00 cfs @ 5.00 hrs HW=801.00' (Free Discharge)
 ↑5=Broad-Crested Rectangular Weir (Controls 0.00 cfs)

Pond 17P: DET 220

Hydrograph

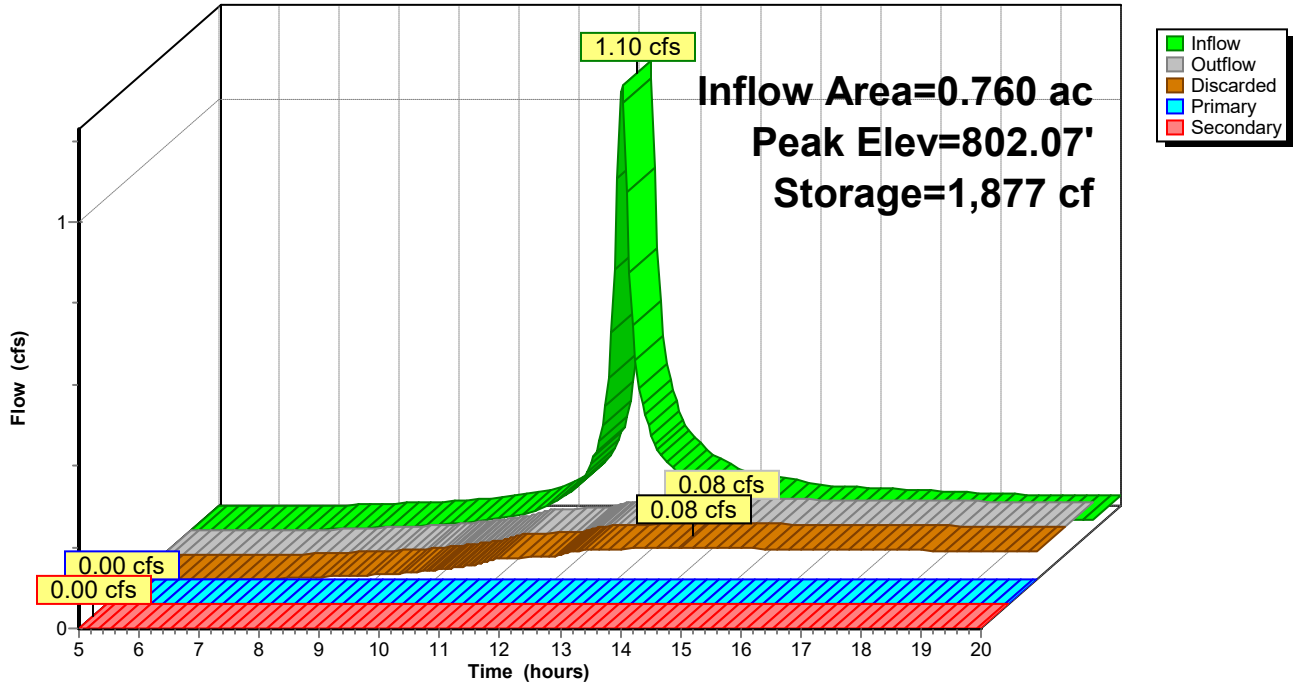

Summary for Pond 23P: WQ 140

Inflow Area = 0.330 ac, 0.00% Impervious, Inflow Depth > 1.01" for 1-Year event
 Inflow = 0.40 cfs @ 12.15 hrs, Volume= 0.028 af
 Outflow = 0.02 cfs @ 15.41 hrs, Volume= 0.005 af, Atten= 96%, Lag= 195.7 min
 Primary = 0.02 cfs @ 15.41 hrs, Volume= 0.005 af
 Routed to Link 15L : PR POA / A

Routing by Stor-Ind method, Time Span= 5.00-20.00 hrs, dt= 0.05 hrs
 Peak Elev= 838.51' @ 15.41 hrs Surf.Area= 1,144 sf Storage= 976 cf

Plug-Flow detention time= 344.6 min calculated for 0.005 af (19% of inflow)
 Center-of-Mass det. time= 230.9 min (1,036.0 - 805.0)

Volume	Invert	Avail.Storage	Storage Description
#1	837.50'	1,554 cf	Custom Stage Data (Prismatic) Listed below (Recalc)
Elevation (feet)	Surf.Area (sq-ft)	Inc.Store (cubic-feet)	Cum.Store (cubic-feet)
837.50	801	0	0
838.00	964	441	441
838.50	1,143	527	968
839.00	1,200	586	1,554

Device	Routing	Invert	Outlet Devices
#1	Primary	838.50'	10.0' long + 3.0 ' SideZ x 8.0' breadth Broad-Crested Rectangular Weir Head (feet) 0.20 0.40 0.60 0.80 1.00 1.20 1.40 1.60 1.80 2.00 2.50 3.00 3.50 4.00 4.50 5.00 5.50 Coef. (English) 2.43 2.54 2.70 2.69 2.68 2.68 2.66 2.64 2.64 2.64 2.65 2.65 2.66 2.66 2.68 2.70 2.74

Primary OutFlow Max=0.02 cfs @ 15.41 hrs HW=838.51' (Free Discharge)
 ↑1=**Broad-Crested Rectangular Weir** (Weir Controls 0.02 cfs @ 0.21 fps)

Pond 23P: WQ 140

Hydrograph

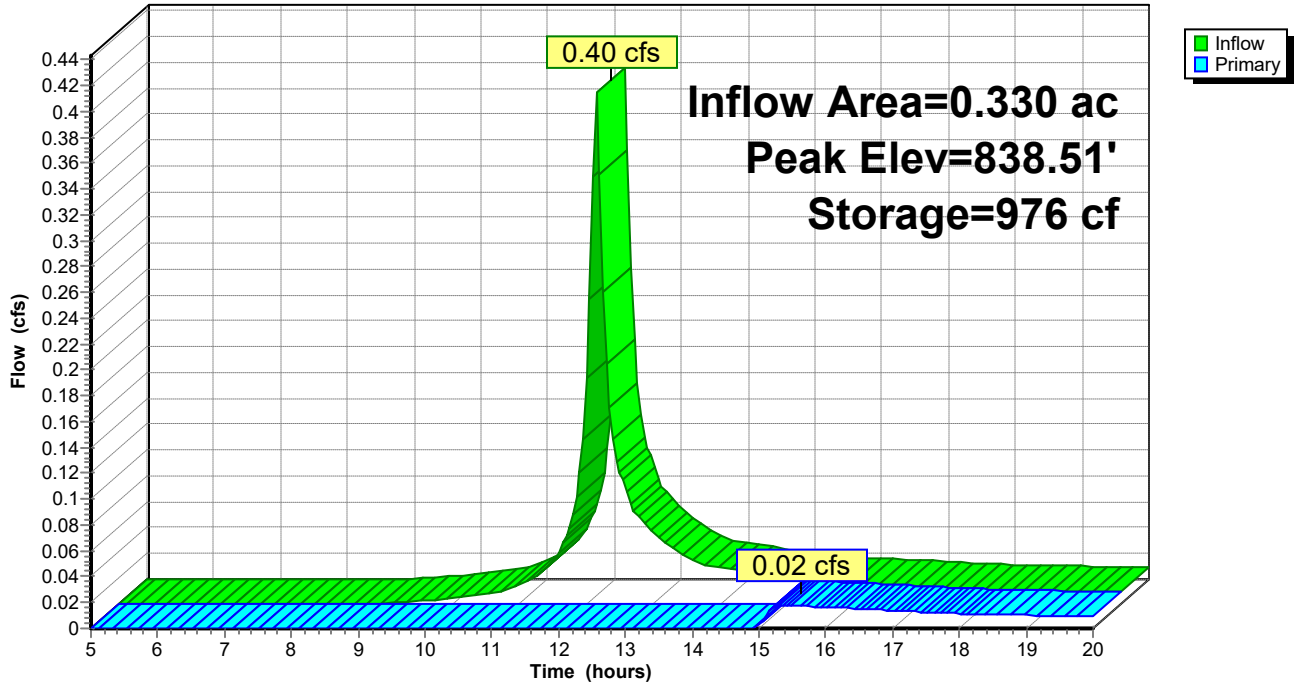

Summary for Link 4L: EX POA / A

Inflow Area = 18.510 ac, 0.00% Impervious, Inflow Depth > 0.46" for 1-Year event
Inflow = 4.21 cfs @ 12.60 hrs, Volume= 0.709 af
Primary = 4.21 cfs @ 12.60 hrs, Volume= 0.709 af, Atten= 0%, Lag= 0.0 min

Primary outflow = Inflow, Time Span= 5.00-20.00 hrs, dt= 0.05 hrs

Link 4L: EX POA / A

Hydrograph

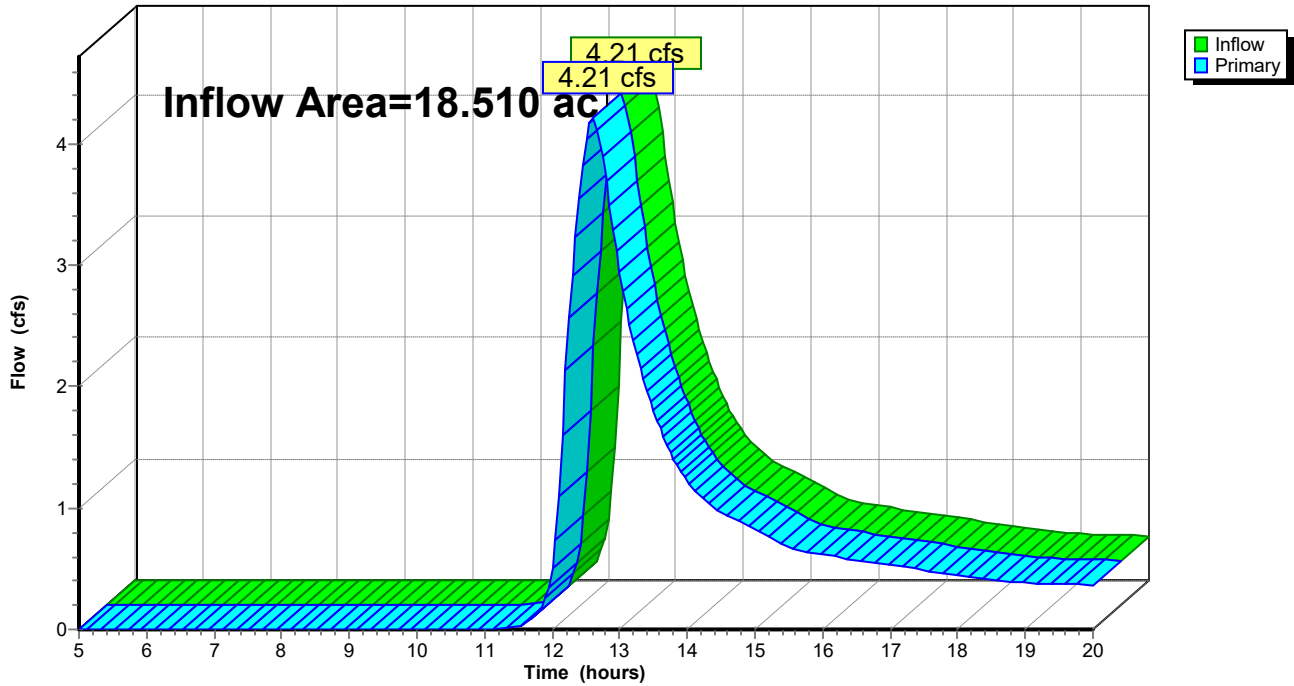

Summary for Link 15L: PR POA / A

Inflow Area = 17.850 ac, 0.00% Impervious, Inflow Depth > 0.46" for 1-Year event
Inflow = 3.99 cfs @ 12.60 hrs, Volume= 0.680 af
Primary = 3.99 cfs @ 12.60 hrs, Volume= 0.680 af, Atten= 0%, Lag= 0.0 min

Primary outflow = Inflow, Time Span= 5.00-20.00 hrs, dt= 0.05 hrs

Link 15L: PR POA / A

Hydrograph

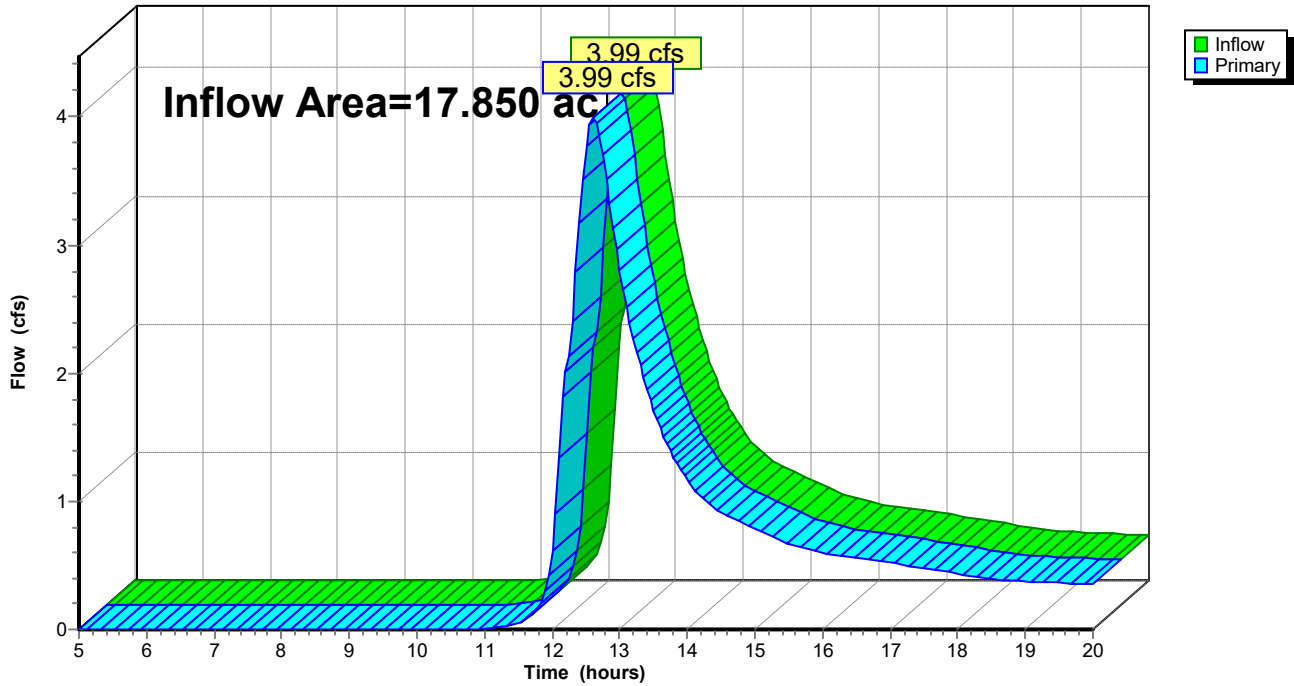

Summary for Link 18L: PR POA / B

Inflow Area = 6.180 ac, 0.00% Impervious, Inflow Depth > 0.35" for 1-Year event
Inflow = 1.96 cfs @ 12.25 hrs, Volume= 0.180 af
Primary = 1.96 cfs @ 12.25 hrs, Volume= 0.180 af, Atten= 0%, Lag= 0.0 min

Primary outflow = Inflow, Time Span= 5.00-20.00 hrs, dt= 0.05 hrs

Link 18L: PR POA / B

Hydrograph

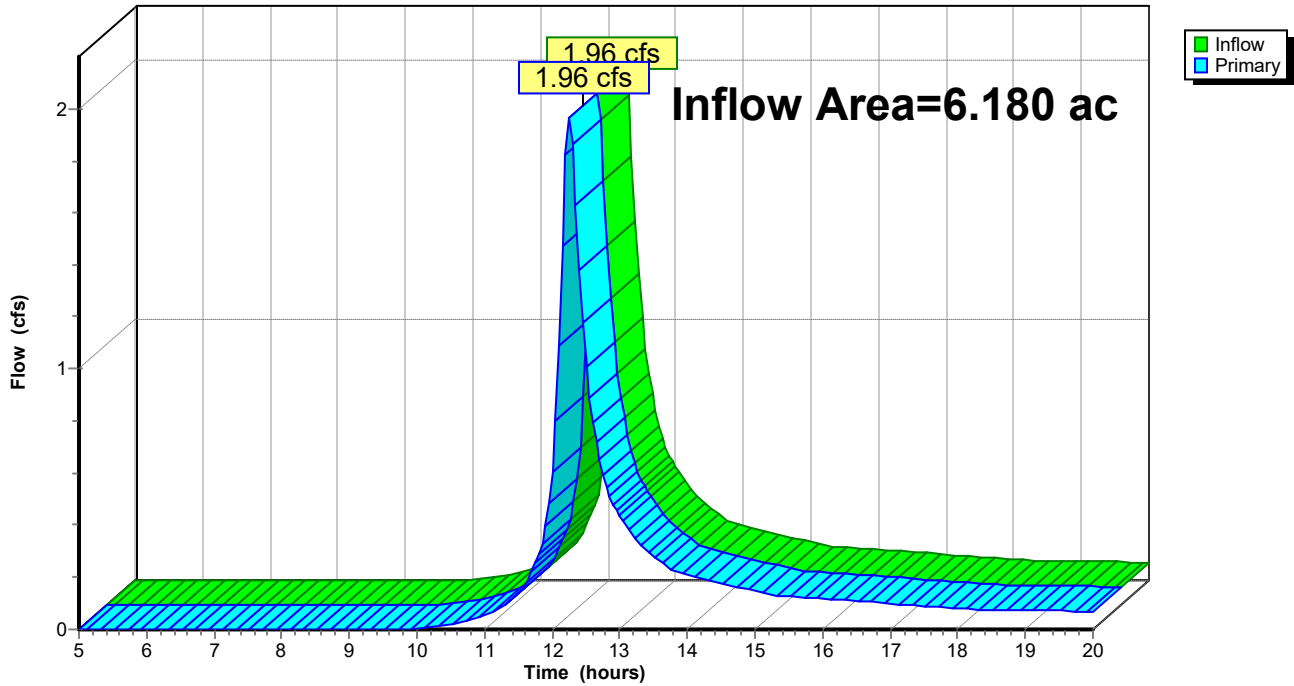

Summary for Subcatchment 1S: EXWS-10

Runoff = 2.21 cfs @ 12.23 hrs, Volume= 0.196 af, Depth> 0.95"
Routed to Link 4L : EX POA / A

Runoff by SCS TR-20 method, UH=SCS, Weighted-CN, Time Span= 5.00-20.00 hrs, dt= 0.05 hrs
NOAA 24-hr D 2-Year Rainfall=3.08"

Table with 3 columns: Area (ac), CN, Description. Row 1: 2.460, 76, 100.00% Pervious Area.

Table with 7 columns: Tc (min), Length (feet), Slope (ft/ft), Velocity (ft/sec), Capacity (cfs), Description. Row 1: 14.2, Direct Entry,

Subcatchment 1S: EXWS-10

Hydrograph

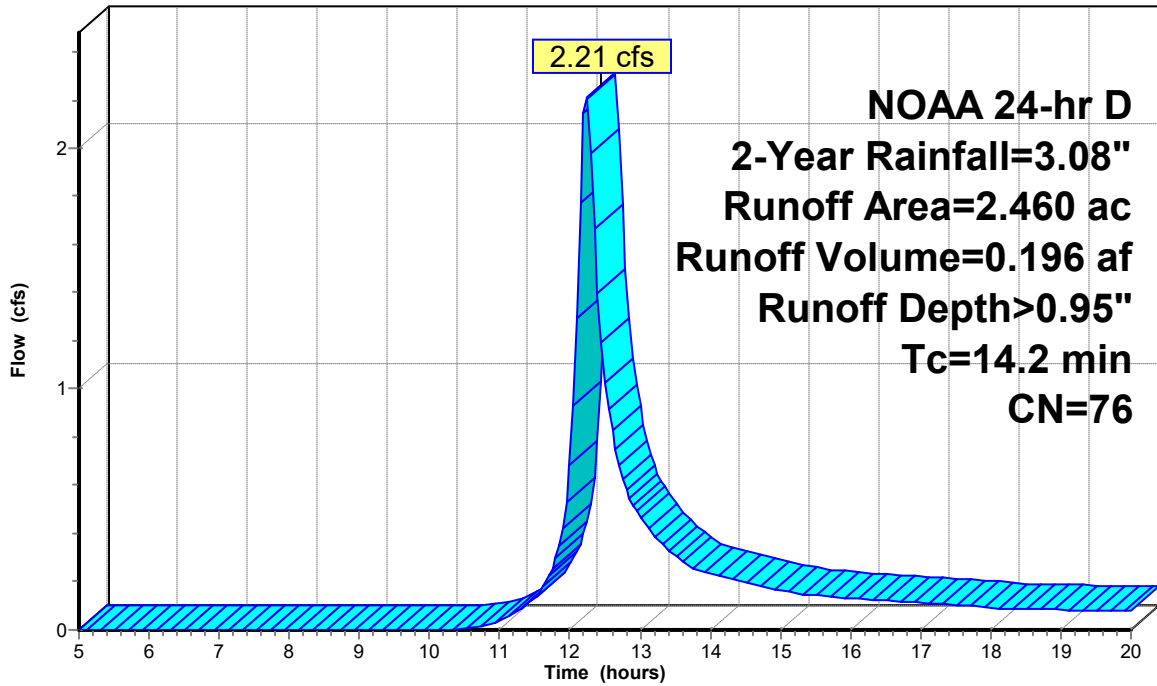

Runoff

Summary for Subcatchment 2S: EXWS-11

Runoff = 7.18 cfs @ 12.59 hrs, Volume= 1.057 af, Depth> 0.79"
Routed to Link 4L : EX POA / A

Runoff by SCS TR-20 method, UH=SCS, Weighted-CN, Time Span= 5.00-20.00 hrs, dt= 0.05 hrs
NOAA 24-hr D 2-Year Rainfall=3.08"

Table with 3 columns: Area (ac), CN, Description. Row 1: 16.050, 73, 100.00% Pervious Area

Table with 7 columns: Tc (min), Length (feet), Slope (ft/ft), Velocity (ft/sec), Capacity (cfs), Description. Row 1: 39.6, Direct Entry,

Subcatchment 2S: EXWS-11

Hydrograph

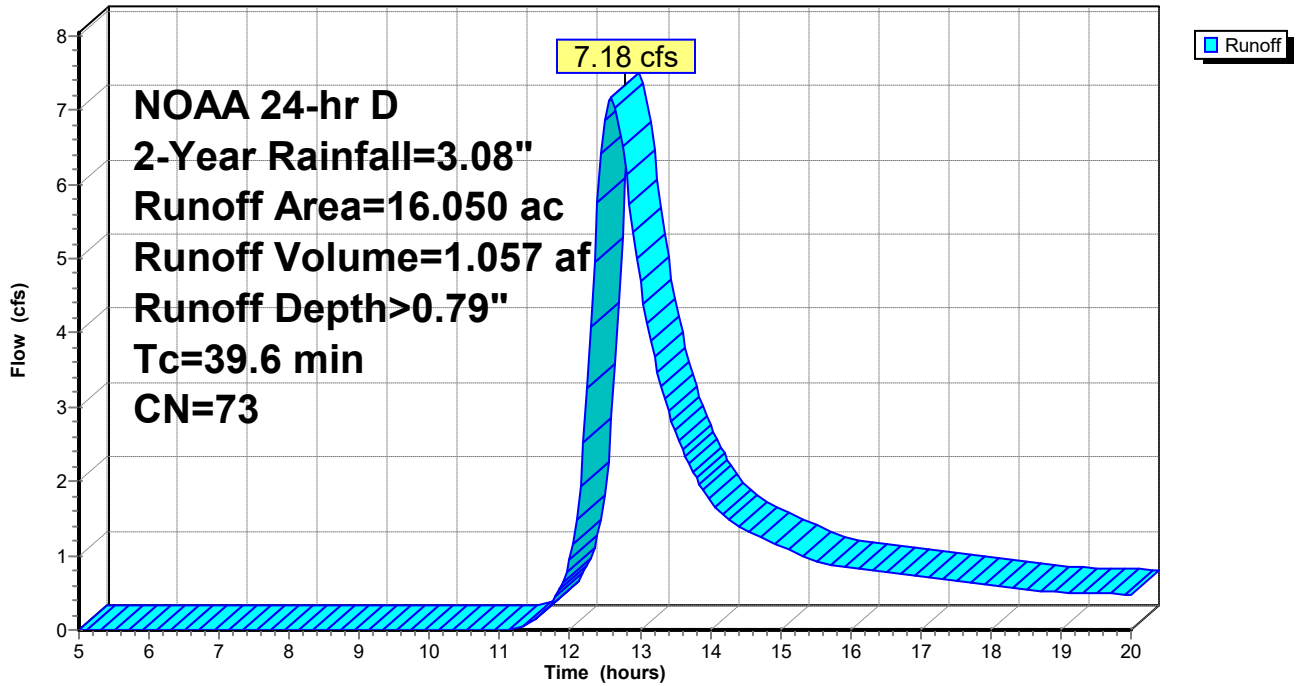

Summary for Subcatchment 5S: EXWS-20 / B

Runoff = 6.14 cfs @ 12.24 hrs, Volume= 0.545 af, Depth> 1.31"

Runoff by SCS TR-20 method, UH=SCS, Weighted-CN, Time Span= 5.00-20.00 hrs, dt= 0.05 hrs
 NOAA 24-hr D 2-Year Rainfall=3.08"

Area (ac)	CN	Description
* 5.000	82	
5.000		100.00% Pervious Area

Tc (min)	Length (feet)	Slope (ft/ft)	Velocity (ft/sec)	Capacity (cfs)	Description
14.9					Direct Entry,

Subcatchment 5S: EXWS-20 / B

Hydrograph

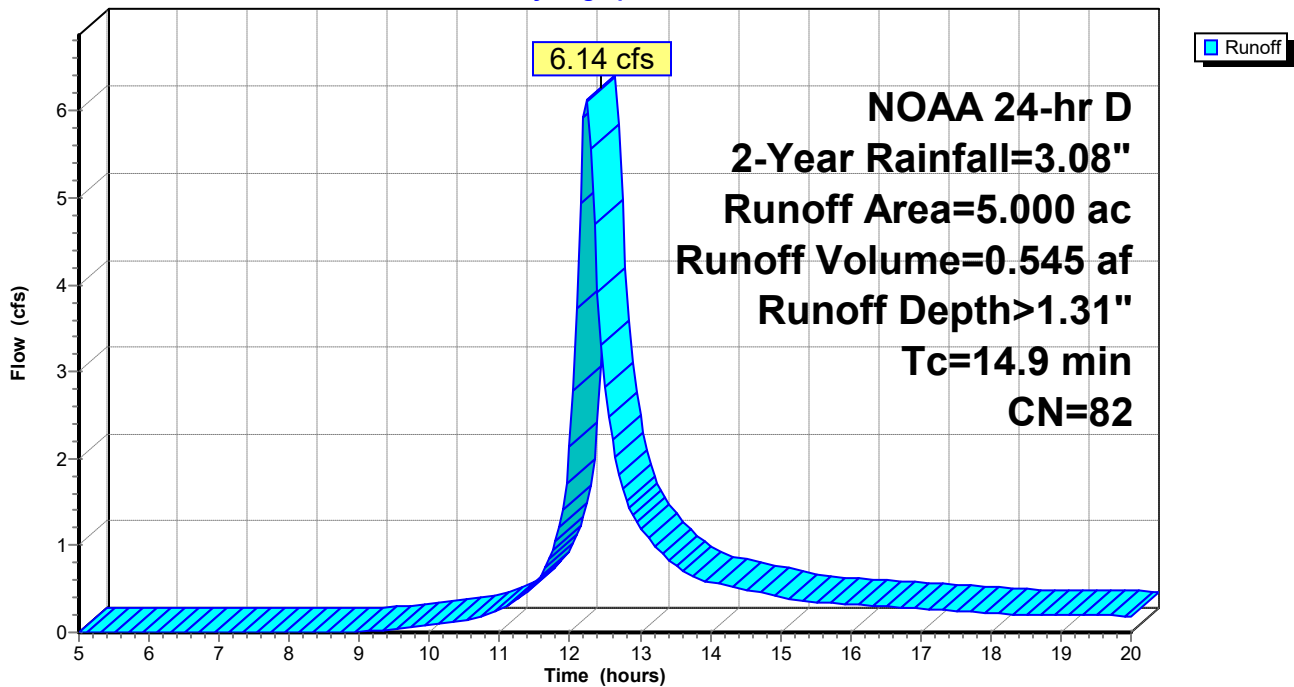

Summary for Subcatchment 6S: EXWS-30 / C

Runoff = 1.61 cfs @ 12.23 hrs, Volume= 0.140 af, Depth> 1.01"

Runoff by SCS TR-20 method, UH=SCS, Weighted-CN, Time Span= 5.00-20.00 hrs, dt= 0.05 hrs
NOAA 24-hr D 2-Year Rainfall=3.08"

Area (ac)	CN	Description
* 1.670	77	
1.670		100.00% Pervious Area

Tc (min)	Length (feet)	Slope (ft/ft)	Velocity (ft/sec)	Capacity (cfs)	Description
14.0					Direct Entry,

Subcatchment 6S: EXWS-30 / C

Hydrograph

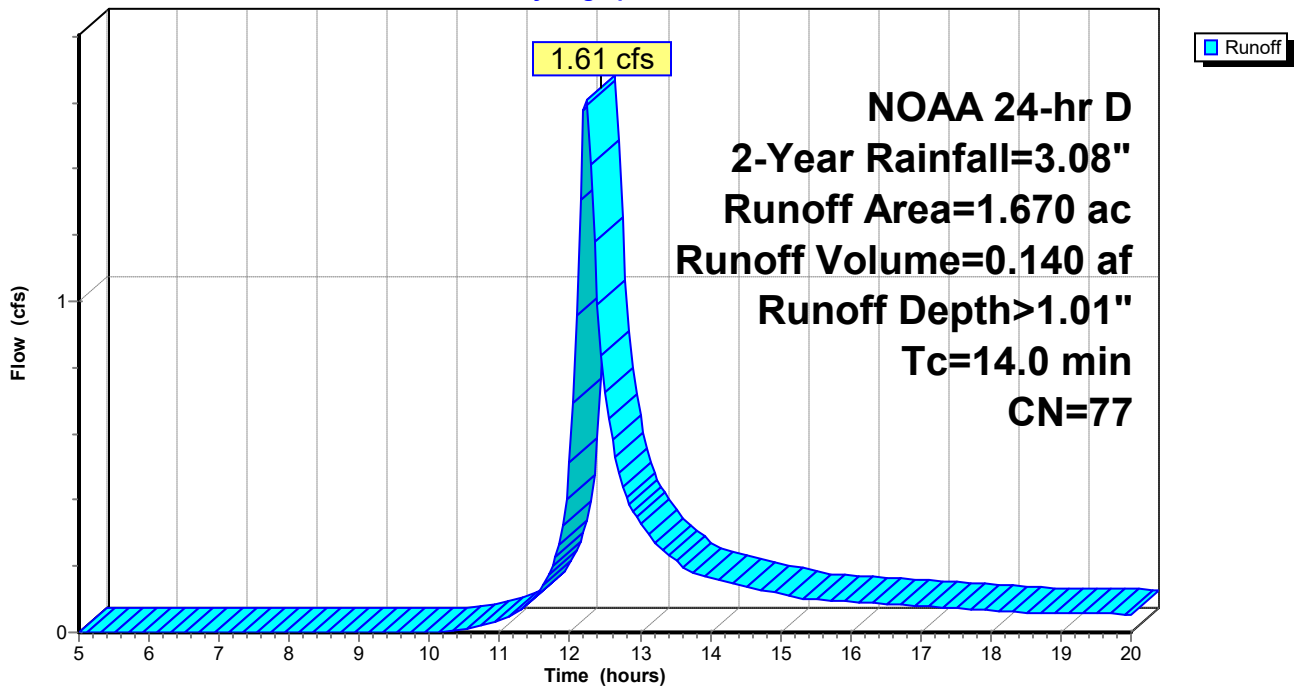

Summary for Subcatchment 7S: PRWS-10

Runoff = 2.00 cfs @ 12.16 hrs, Volume= 0.142 af, Depth> 1.07"
Routed to Link 15L : PR POA / A

Runoff by SCS TR-20 method, UH=SCS, Weighted-CN, Time Span= 5.00-20.00 hrs, dt= 0.05 hrs
NOAA 24-hr D 2-Year Rainfall=3.08"

Area (ac)	CN	Description
* 1.600	78	
1.600		100.00% Pervious Area

Tc (min)	Length (feet)	Slope (ft/ft)	Velocity (ft/sec)	Capacity (cfs)	Description
8.2					Direct Entry,

Subcatchment 7S: PRWS-10

Hydrograph

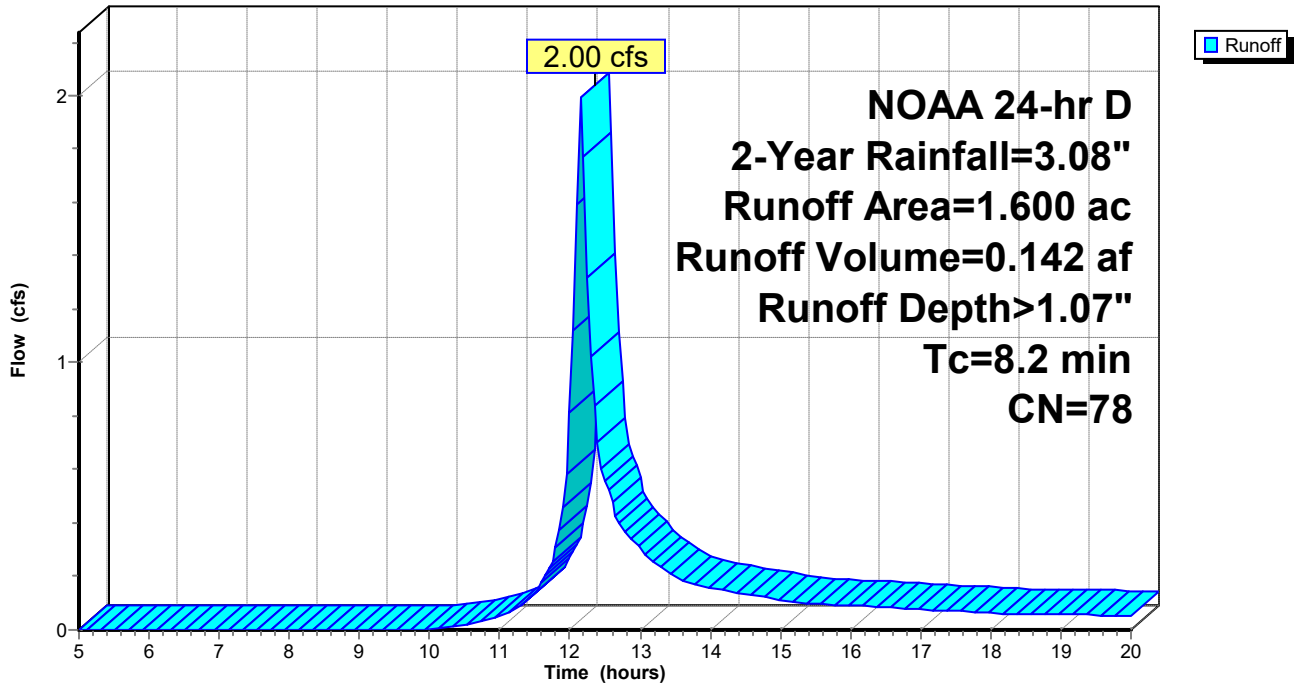

Summary for Subcatchment 8S: PRWS-11

Runoff = 7.14 cfs @ 12.59 hrs, Volume= 1.049 af, Depth> 0.79"
Routed to Link 15L : PR POA / A

Runoff by SCS TR-20 method, UH=SCS, Weighted-CN, Time Span= 5.00-20.00 hrs, dt= 0.05 hrs
NOAA 24-hr D 2-Year Rainfall=3.08"

Table with 3 columns: Area (ac), CN, Description. Row 1: 15.920, 73, 100.00% Pervious Area

Table with 7 columns: Tc (min), Length (feet), Slope (ft/ft), Velocity (ft/sec), Capacity (cfs), Description. Row 1: 39.5, Direct Entry,

Subcatchment 8S: PRWS-11

Hydrograph

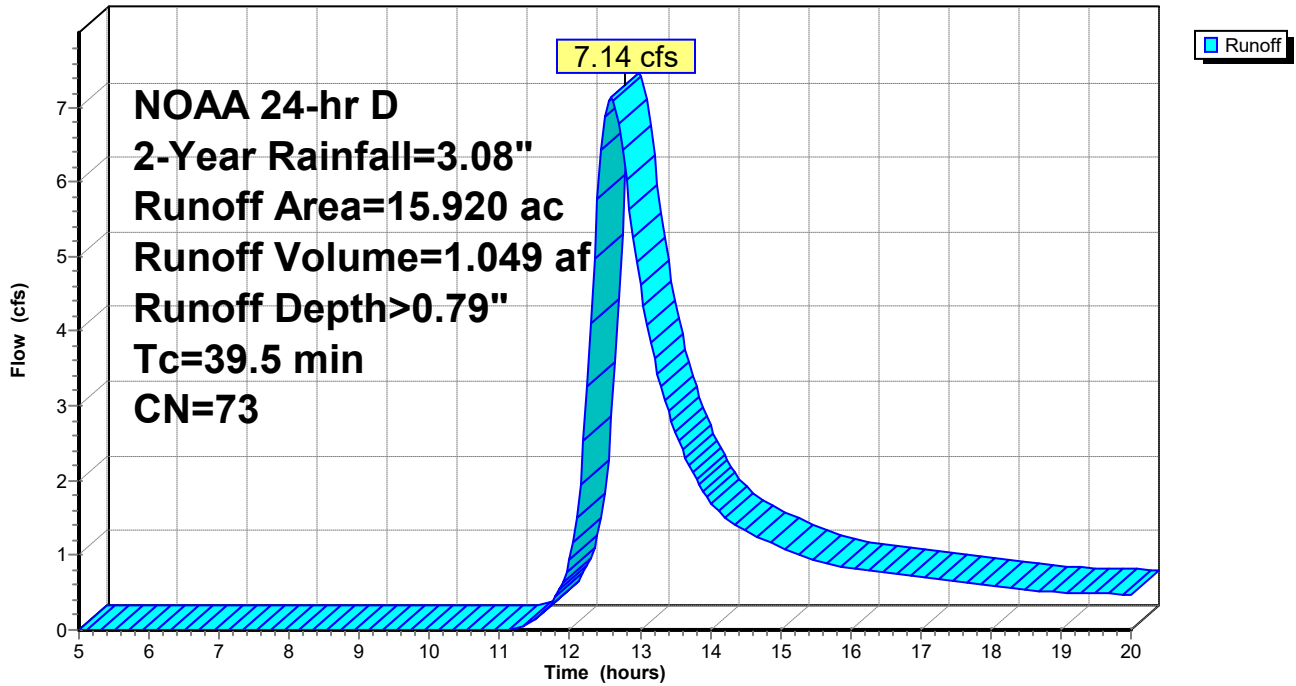

Summary for Subcatchment 10S: PRWS-20

Runoff = 3.09 cfs @ 12.25 hrs, Volume= 0.281 af, Depth> 1.31"
Routed to Link 18L : PR POA / B

Runoff by SCS TR-20 method, UH=SCS, Weighted-CN, Time Span= 5.00-20.00 hrs, dt= 0.05 hrs
NOAA 24-hr D 2-Year Rainfall=3.08"

Area (ac)	CN	Description
* 2.580	82	
2.580		100.00% Pervious Area

Tc (min)	Length (feet)	Slope (ft/ft)	Velocity (ft/sec)	Capacity (cfs)	Description
15.9					Direct Entry,

Subcatchment 10S: PRWS-20

Hydrograph

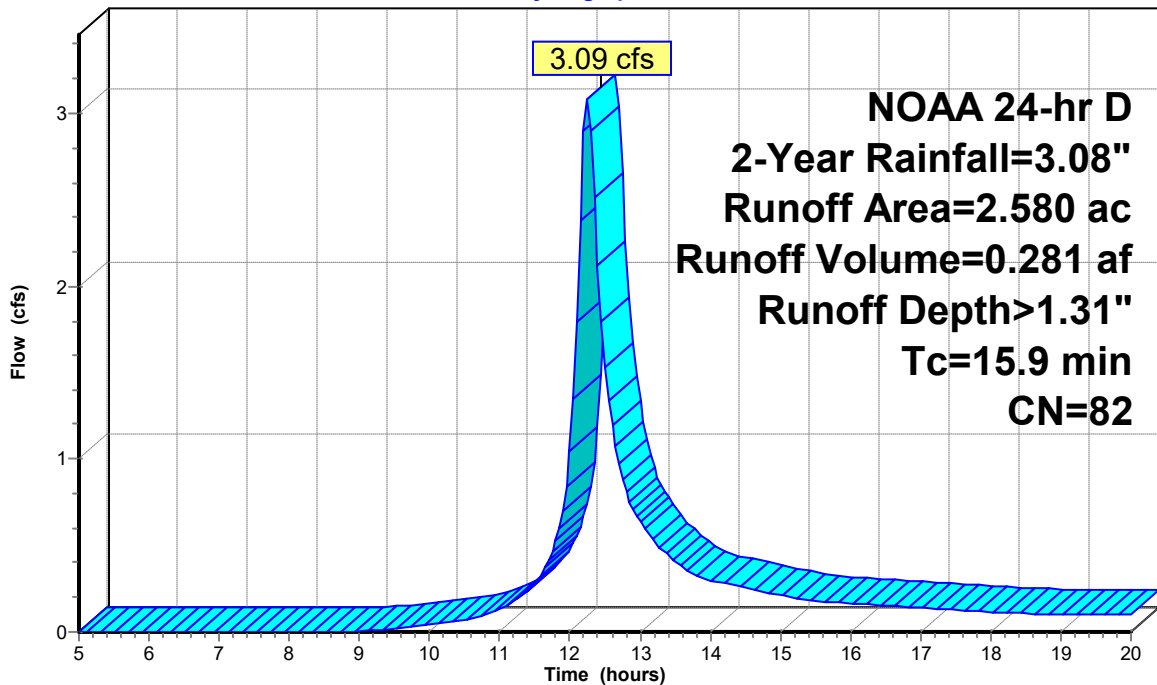

Runoff

Summary for Subcatchment 11S: PRWS-21

Runoff = 5.61 cfs @ 12.16 hrs, Volume= 0.431 af, Depth> 1.82"
Routed to Pond 16P : DET 210

Runoff by SCS TR-20 method, UH=SCS, Weighted-CN, Time Span= 5.00-20.00 hrs, dt= 0.05 hrs
NOAA 24-hr D 2-Year Rainfall=3.08"

Area (ac)	CN	Description
* 2.840	89	
2.840		100.00% Pervious Area

Tc (min)	Length (feet)	Slope (ft/ft)	Velocity (ft/sec)	Capacity (cfs)	Description
9.4					Direct Entry,

Subcatchment 11S: PRWS-21

Hydrograph

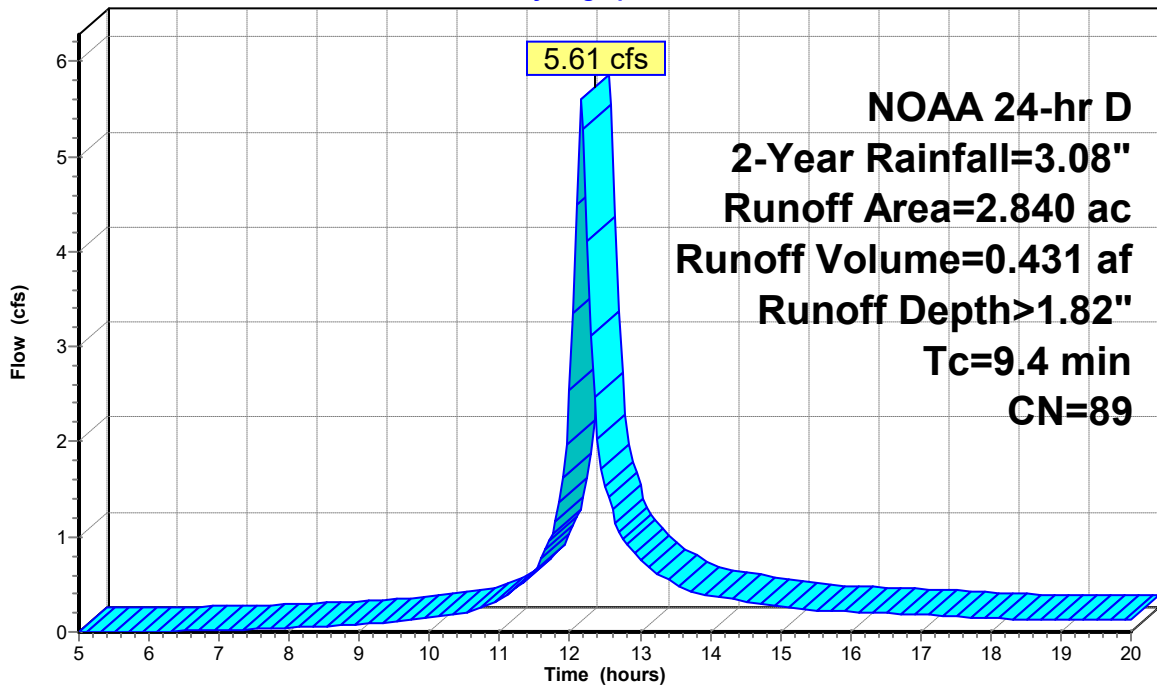

Summary for Subcatchment 12S: PRWS-22

Runoff = 1.54 cfs @ 12.17 hrs, Volume= 0.121 af, Depth> 1.90"
Routed to Pond 17P : DET 220

Runoff by SCS TR-20 method, UH=SCS, Weighted-CN, Time Span= 5.00-20.00 hrs, dt= 0.05 hrs
NOAA 24-hr D 2-Year Rainfall=3.08"

Area (ac)	CN	Description
* 0.760	90	
0.760		100.00% Pervious Area

Tc (min)	Length (feet)	Slope (ft/ft)	Velocity (ft/sec)	Capacity (cfs)	Description
9.7					Direct Entry,

Subcatchment 12S: PRWS-22

Hydrograph

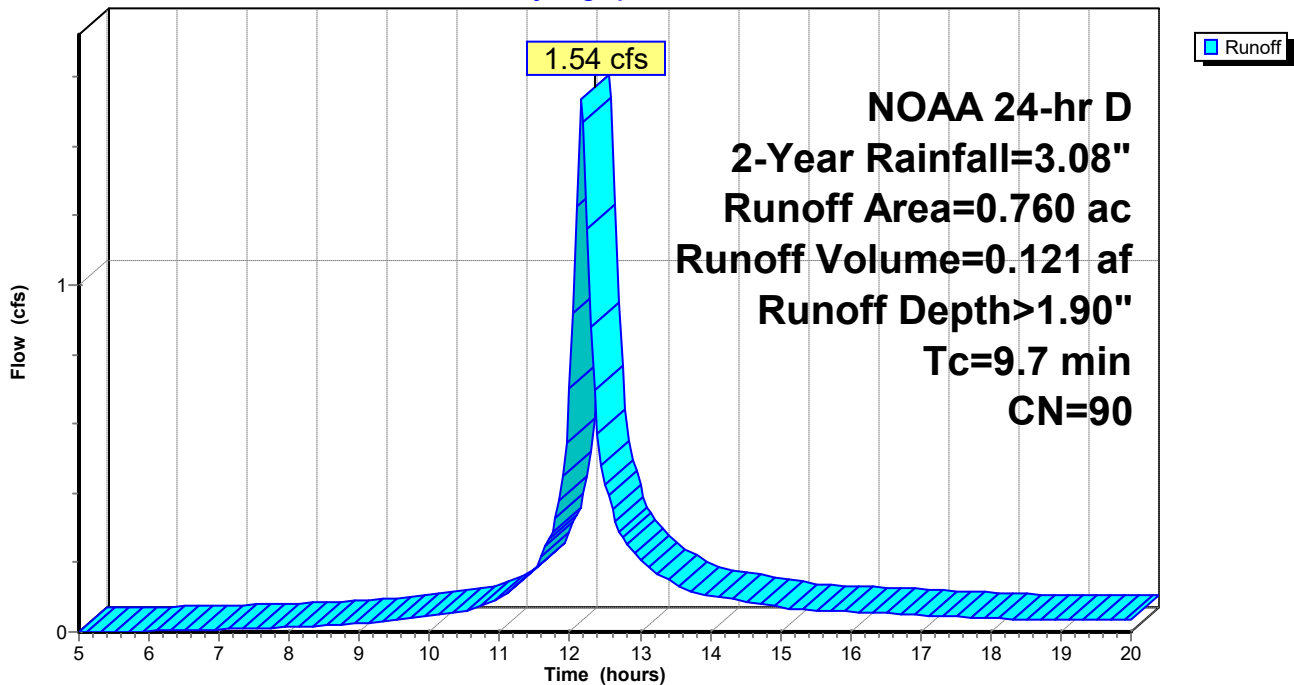

Summary for Subcatchment 13S: PRWS-30 / C

Runoff = 1.18 cfs @ 12.22 hrs, Volume= 0.100 af, Depth> 1.07"

Runoff by SCS TR-20 method, UH=SCS, Weighted-CN, Time Span= 5.00-20.00 hrs, dt= 0.05 hrs
NOAA 24-hr D 2-Year Rainfall=3.08"

Area (ac)	CN	Description
* 1.130	78	
1.130		100.00% Pervious Area

Tc (min)	Length (feet)	Slope (ft/ft)	Velocity (ft/sec)	Capacity (cfs)	Description
13.4					Direct Entry,

Subcatchment 13S: PRWS-30 / C

Hydrograph

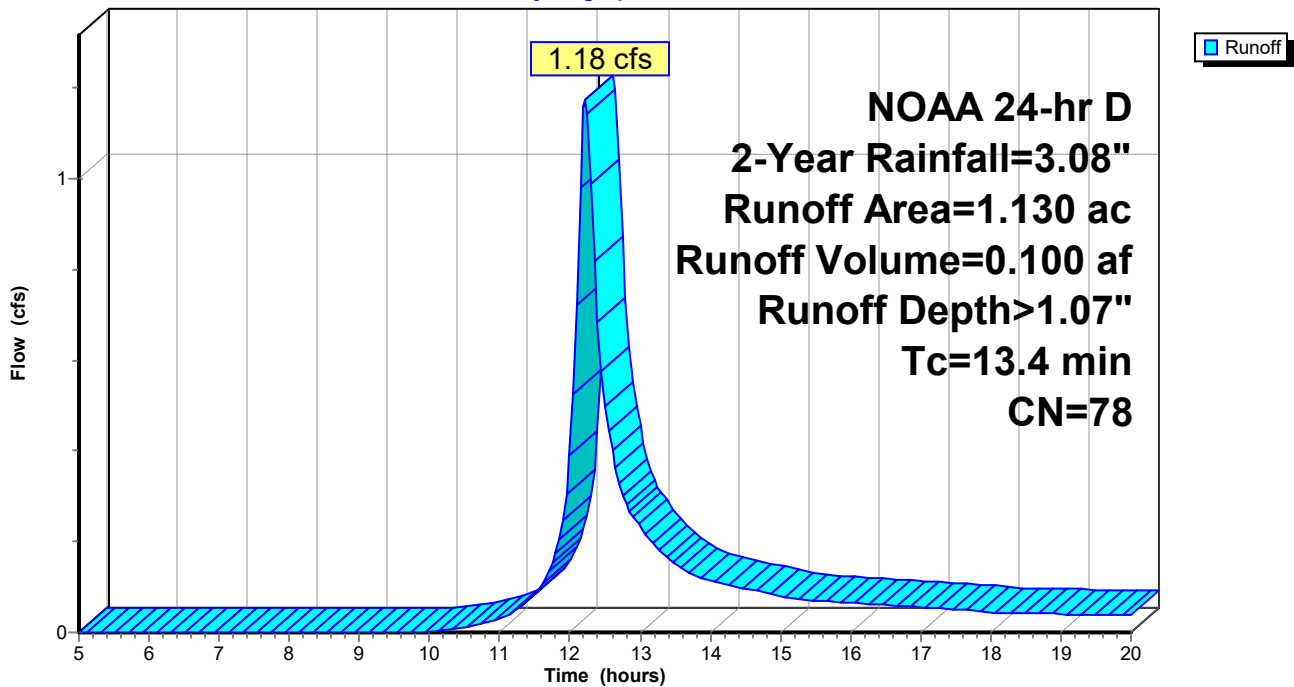

WR-Model06

Prepared by SLR International Corporation
HydroCAD® 10.20-7a s/n 08105 © 2025 HydroCAD Software Solutions LLC

NOAA 24-hr D 2-Year Rainfall=3.08"

Printed 7/24/2025

Page 32

Summary for Subcatchment 20S: PRWS-14

Runoff = 0.59 cfs @ 12.15 hrs, Volume= 0.042 af, Depth> 1.52"
Routed to Pond 23P : WQ 140

Runoff by SCS TR-20 method, UH=SCS, Weighted-CN, Time Span= 5.00-20.00 hrs, dt= 0.05 hrs
NOAA 24-hr D 2-Year Rainfall=3.08"

Area (ac)	CN	Description
* 0.330	85	
0.330		100.00% Pervious Area

Tc (min)	Length (feet)	Slope (ft/ft)	Velocity (ft/sec)	Capacity (cfs)	Description
7.7					Direct Entry,

Subcatchment 20S: PRWS-14

Hydrograph

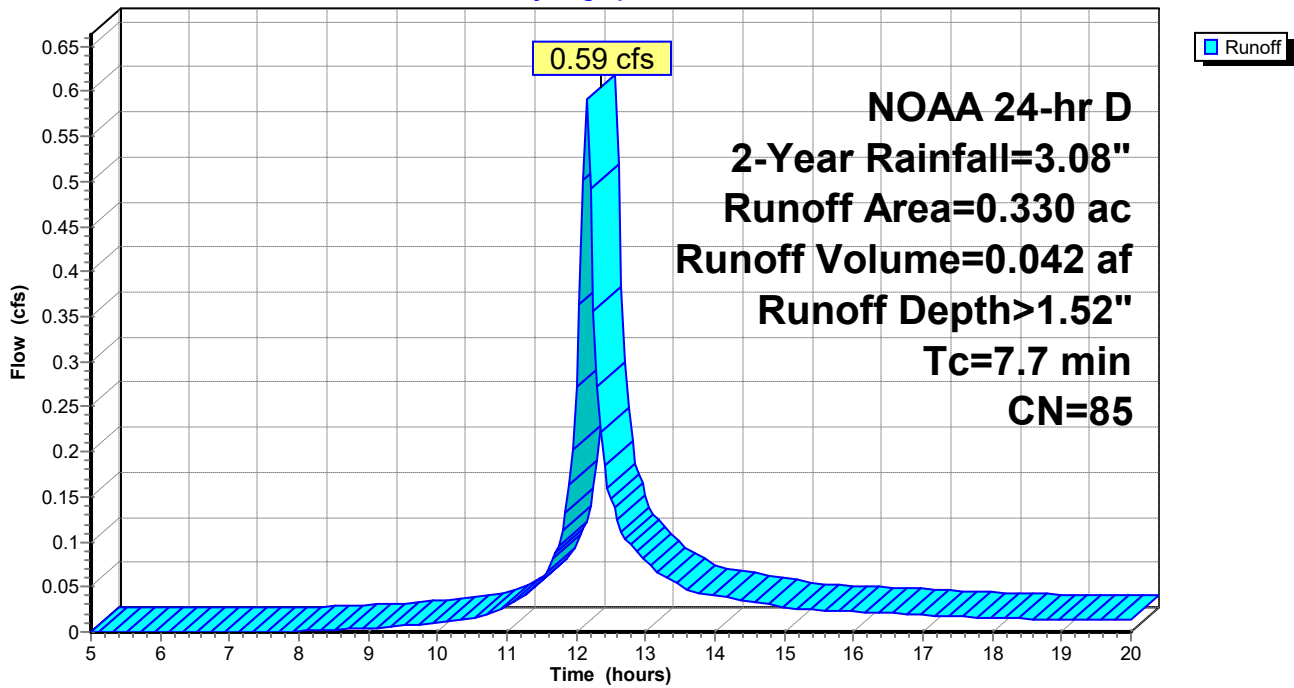

Summary for Pond 16P: DET 210

Inflow Area = 2.840 ac, 0.00% Impervious, Inflow Depth > 1.82" for 2-Year event
 Inflow = 5.61 cfs @ 12.16 hrs, Volume= 0.431 af
 Outflow = 0.62 cfs @ 13.24 hrs, Volume= 0.430 af, Atten= 89%, Lag= 64.3 min
 Discarded = 0.61 cfs @ 13.24 hrs, Volume= 0.430 af
 Primary = 0.01 cfs @ 13.24 hrs, Volume= 0.000 af
 Routed to Link 18L : PR POA / B
 Secondary = 0.00 cfs @ 5.00 hrs, Volume= 0.000 af
 Routed to Link 18L : PR POA / B

Routing by Stor-Ind method, Time Span= 5.00-20.00 hrs, dt= 0.05 hrs
 Peak Elev= 815.90' @ 13.24 hrs Surf.Area= 8,781 sf Storage= 7,409 cf

Plug-Flow detention time= 107.7 min calculated for 0.430 af (100% of inflow)
 Center-of-Mass det. time= 106.6 min (889.3 - 782.7)

Volume	Invert	Avail.Storage	Storage Description	
#1	815.00'	28,886 cf	Custom Stage Data (Conic) Listed below (Recalc)	
Elevation (feet)	Surf.Area (sq-ft)	Inc.Store (cubic-feet)	Cum.Store (cubic-feet)	Wet.Area (sq-ft)
815.00	7,672	0	0	7,672
816.00	8,907	8,282	8,282	8,948
817.00	10,296	9,593	17,875	10,380
818.00	11,741	11,011	28,886	11,872

Device	Routing	Invert	Outlet Devices
#1	Discarded	815.00'	3.000 in/hr Exfiltration over Surface area
#2	Primary	814.50'	15.0" Round Culvert L= 127.0' CPP, projecting, no headwall, Ke= 0.900 Inlet / Outlet Invert= 814.50' / 806.40' S= 0.0638 '/' Cc= 0.900 n= 0.012, Flow Area= 1.23 sf
#3	Device 2	815.90'	14.0' long Sharp-Crested Rectangular Weir 2 End Contraction(s)
#4	Secondary	817.20'	10.0' long + 3.0 ' SideZ x 8.0' breadth Broad-Crested Rectangular Weir Head (feet) 0.20 0.40 0.60 0.80 1.00 1.20 1.40 1.60 1.80 2.00 2.50 3.00 3.50 4.00 4.50 5.00 5.50 Coef. (English) 2.43 2.54 2.70 2.69 2.68 2.68 2.66 2.64 2.64 2.64 2.65 2.65 2.66 2.66 2.68 2.70 2.74

Discarded OutFlow Max=0.61 cfs @ 13.24 hrs HW=815.90' (Free Discharge)
 ↑1=Exfiltration (Exfiltration Controls 0.61 cfs)

Primary OutFlow Max=0.00 cfs @ 13.24 hrs HW=815.90' (Free Discharge)
 ↑2=Culvert (Passes 0.00 cfs of 4.11 cfs potential flow)
 ↑3=Sharp-Crested Rectangular Weir (Weir Controls 0.00 cfs @ 0.12 fps)

Secondary OutFlow Max=0.00 cfs @ 5.00 hrs HW=815.00' (Free Discharge)
 ↑4=Broad-Crested Rectangular Weir (Controls 0.00 cfs)

Pond 16P: DET 210

Hydrograph

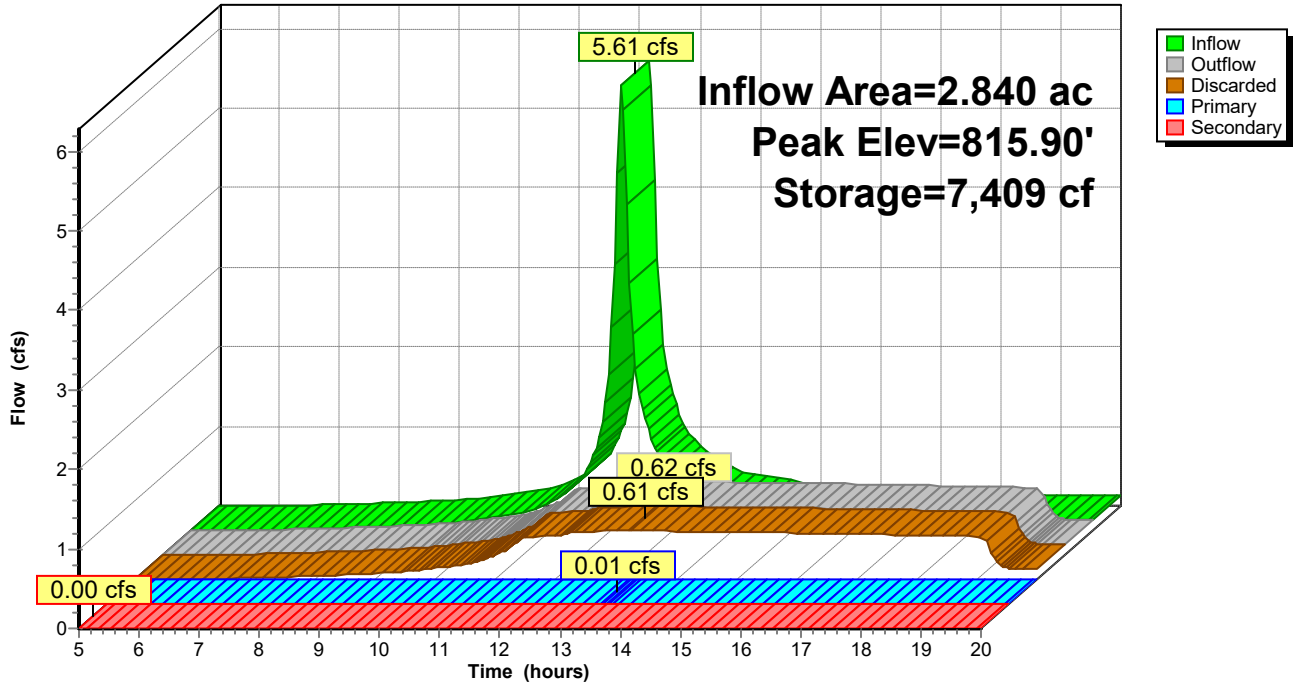

Summary for Pond 17P: DET 220

Inflow Area = 0.760 ac, 0.00% Impervious, Inflow Depth > 1.90" for 2-Year event
 Inflow = 1.54 cfs @ 12.17 hrs, Volume= 0.121 af
 Outflow = 0.19 cfs @ 13.14 hrs, Volume= 0.081 af, Atten= 88%, Lag= 58.6 min
 Discarded = 0.08 cfs @ 13.14 hrs, Volume= 0.067 af
 Primary = 0.10 cfs @ 13.14 hrs, Volume= 0.014 af
 Routed to Link 18L : PR POA / B
 Secondary = 0.00 cfs @ 5.00 hrs, Volume= 0.000 af
 Routed to Link 18L : PR POA / B

Routing by Stor-Ind method, Time Span= 5.00-20.00 hrs, dt= 0.05 hrs
 Peak Elev= 802.39' @ 13.14 hrs Surf.Area= 2,324 sf Storage= 2,574 cf

Plug-Flow detention time= 167.6 min calculated for 0.081 af (67% of inflow)
 Center-of-Mass det. time= 95.8 min (874.8 - 779.1)

Volume	Invert	Avail.Storage	Storage Description		
#1	801.00'	7,722 cf	Custom Stage Data (Conic) Listed below (Recalc)		
Elevation (feet)	Surf.Area (sq-ft)	Inc.Store (cubic-feet)	Cum.Store (cubic-feet)	Wet.Area (sq-ft)	
801.00	1,433	0	0	1,433	
802.00	2,039	1,727	1,727	2,057	
803.00	2,810	2,414	4,141	2,847	
804.00	4,412	3,581	7,722	4,463	

Device	Routing	Invert	Outlet Devices	
#1	Discarded	801.00'	1.580 in/hr Exfiltration over Surface area	
#2	Primary	800.50'	15.0" Round Culvert L= 39.0' CPP, projecting, no headwall, Ke= 0.900 Inlet / Outlet Invert= 800.50' / 800.00' S= 0.0128 '/' Cc= 0.900 n= 0.012, Flow Area= 1.23 sf	
#3	Device 2	802.20'	6.0" Vert. Orifice/Grate C= 0.600 Limited to weir flow at low heads	
#4	Device 2	802.80'	14.0' long Sharp-Crested Rectangular Weir 2 End Contraction(s)	
#5	Secondary	803.00'	10.0' long + 3.0 ' SideZ x 8.0' breadth Broad-Crested Rectangular Weir Head (feet) 0.20 0.40 0.60 0.80 1.00 1.20 1.40 1.60 1.80 2.00 2.50 3.00 3.50 4.00 4.50 5.00 5.50 Coef. (English) 2.43 2.54 2.70 2.69 2.68 2.68 2.66 2.64 2.64 2.64 2.65 2.65 2.66 2.66 2.68 2.70 2.74	

Discarded OutFlow Max=0.08 cfs @ 13.14 hrs HW=802.39' (Free Discharge)
 ↑1=Exfiltration (Exfiltration Controls 0.08 cfs)

Primary OutFlow Max=0.10 cfs @ 13.14 hrs HW=802.39' (Free Discharge)
 ↑2=Culvert (Passes 0.10 cfs of 5.24 cfs potential flow)
 ↑3=Orifice/Grate (Orifice Controls 0.10 cfs @ 1.48 fps)
 ↑4=Sharp-Crested Rectangular Weir (Controls 0.00 cfs)

Secondary OutFlow Max=0.00 cfs @ 5.00 hrs HW=801.00' (Free Discharge)
 ↑5=Broad-Crested Rectangular Weir (Controls 0.00 cfs)

Pond 17P: DET 220

Hydrograph

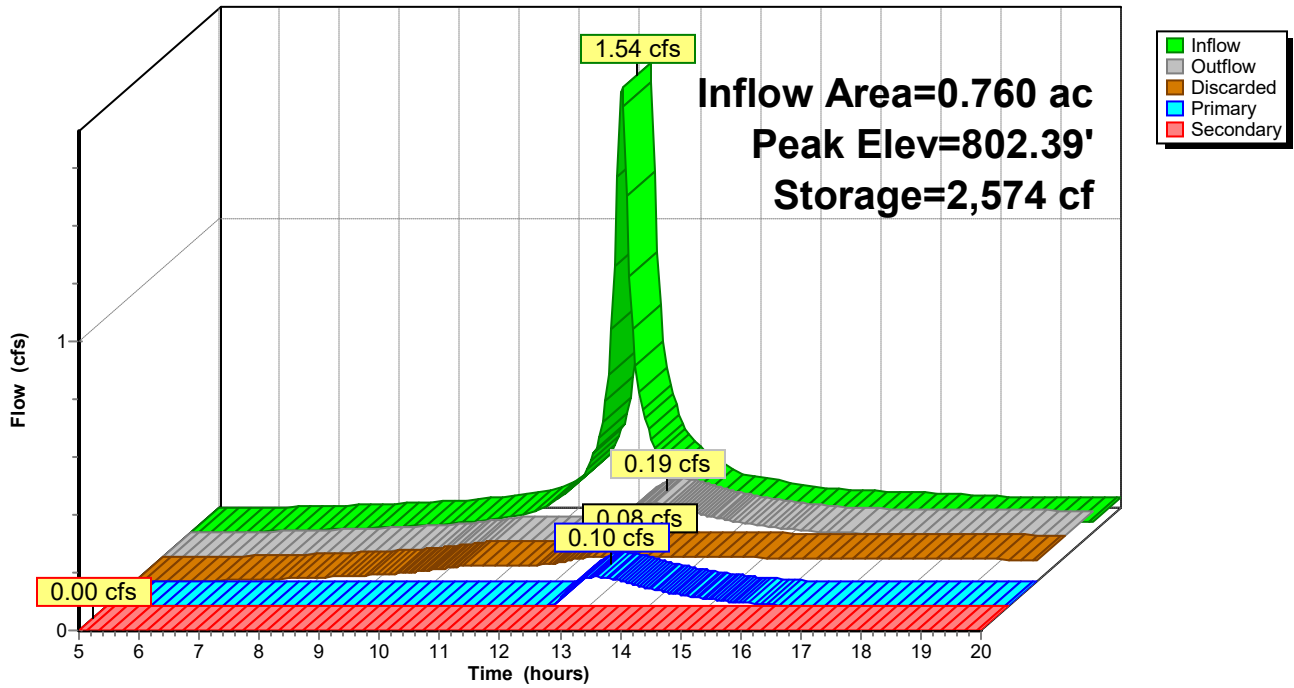

Summary for Pond 23P: WQ 140

Inflow Area = 0.330 ac, 0.00% Impervious, Inflow Depth > 1.52" for 2-Year event
 Inflow = 0.59 cfs @ 12.15 hrs, Volume= 0.042 af
 Outflow = 0.12 cfs @ 12.63 hrs, Volume= 0.019 af, Atten= 80%, Lag= 28.7 min
 Primary = 0.12 cfs @ 12.63 hrs, Volume= 0.019 af
 Routed to Link 15L : PR POA / A

Routing by Stor-Ind method, Time Span= 5.00-20.00 hrs, dt= 0.05 hrs
 Peak Elev= 838.53' @ 12.63 hrs Surf.Area= 1,146 sf Storage= 1,000 cf

Plug-Flow detention time= 188.9 min calculated for 0.019 af (46% of inflow)
 Center-of-Mass det. time= 100.6 min (895.7 - 795.1)

Volume	Invert	Avail.Storage	Storage Description
#1	837.50'	1,554 cf	Custom Stage Data (Prismatic) Listed below (Recalc)
Elevation (feet)	Surf.Area (sq-ft)	Inc.Store (cubic-feet)	Cum.Store (cubic-feet)
837.50	801	0	0
838.00	964	441	441
838.50	1,143	527	968
839.00	1,200	586	1,554

Device	Routing	Invert	Outlet Devices
#1	Primary	838.50'	10.0' long + 3.0 ' SideZ x 8.0' breadth Broad-Crested Rectangular Weir Head (feet) 0.20 0.40 0.60 0.80 1.00 1.20 1.40 1.60 1.80 2.00 2.50 3.00 3.50 4.00 4.50 5.00 5.50 Coef. (English) 2.43 2.54 2.70 2.69 2.68 2.68 2.66 2.64 2.64 2.64 2.65 2.65 2.66 2.66 2.68 2.70 2.74

Primary OutFlow Max=0.11 cfs @ 12.63 hrs HW=838.53' (Free Discharge)
 ↑1=**Broad-Crested Rectangular Weir** (Weir Controls 0.11 cfs @ 0.41 fps)

Pond 23P: WQ 140

Hydrograph

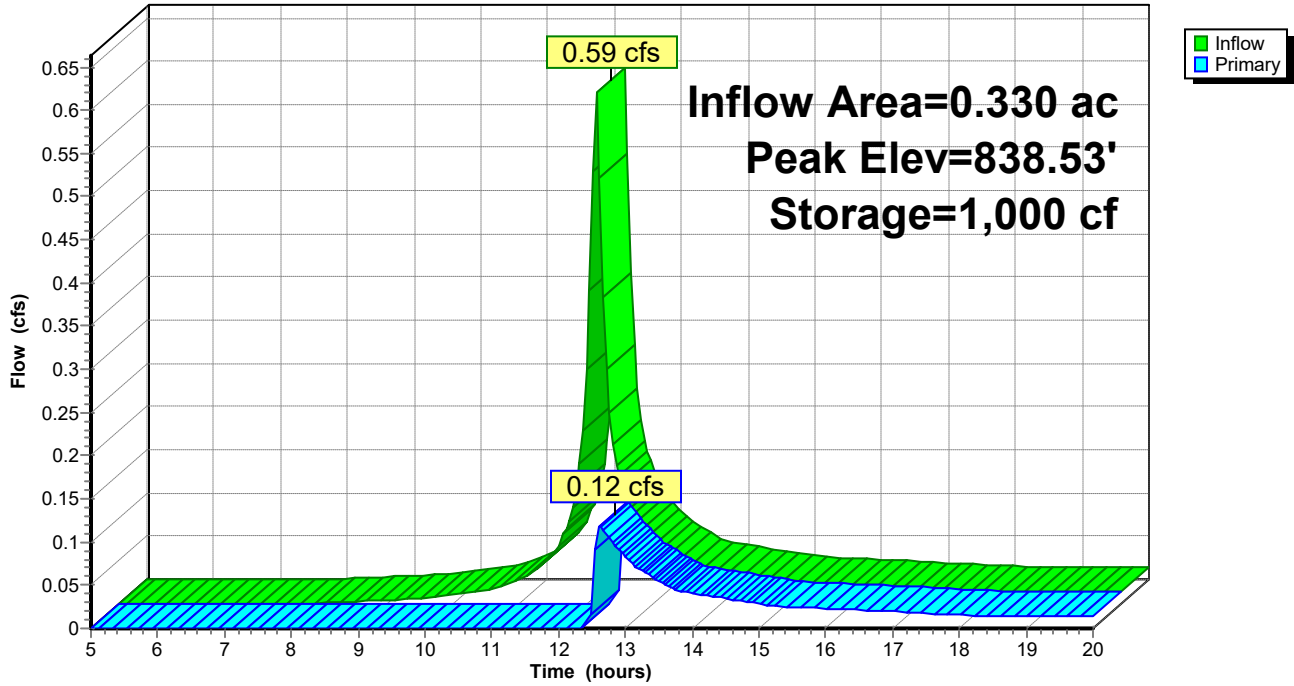

Summary for Link 4L: EX POA / A

Inflow Area = 18.510 ac, 0.00% Impervious, Inflow Depth > 0.81" for 2-Year event
Inflow = 8.05 cfs @ 12.57 hrs, Volume= 1.253 af
Primary = 8.05 cfs @ 12.57 hrs, Volume= 1.253 af, Atten= 0%, Lag= 0.0 min

Primary outflow = Inflow, Time Span= 5.00-20.00 hrs, dt= 0.05 hrs

Link 4L: EX POA / A

Hydrograph

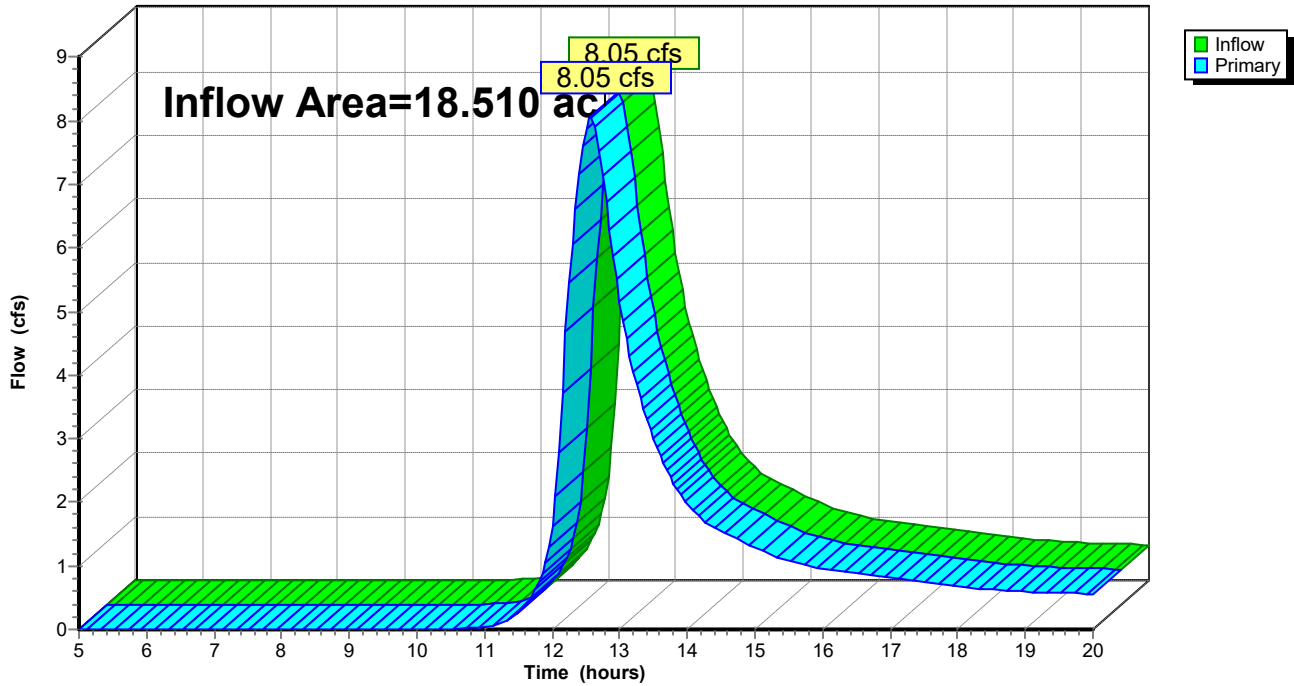

Summary for Link 15L: PR POA / A

Inflow Area = 17.850 ac, 0.00% Impervious, Inflow Depth > 0.81" for 2-Year event
Inflow = 7.75 cfs @ 12.58 hrs, Volume= 1.210 af
Primary = 7.75 cfs @ 12.58 hrs, Volume= 1.210 af, Atten= 0%, Lag= 0.0 min

Primary outflow = Inflow, Time Span= 5.00-20.00 hrs, dt= 0.05 hrs

Link 15L: PR POA / A

Hydrograph

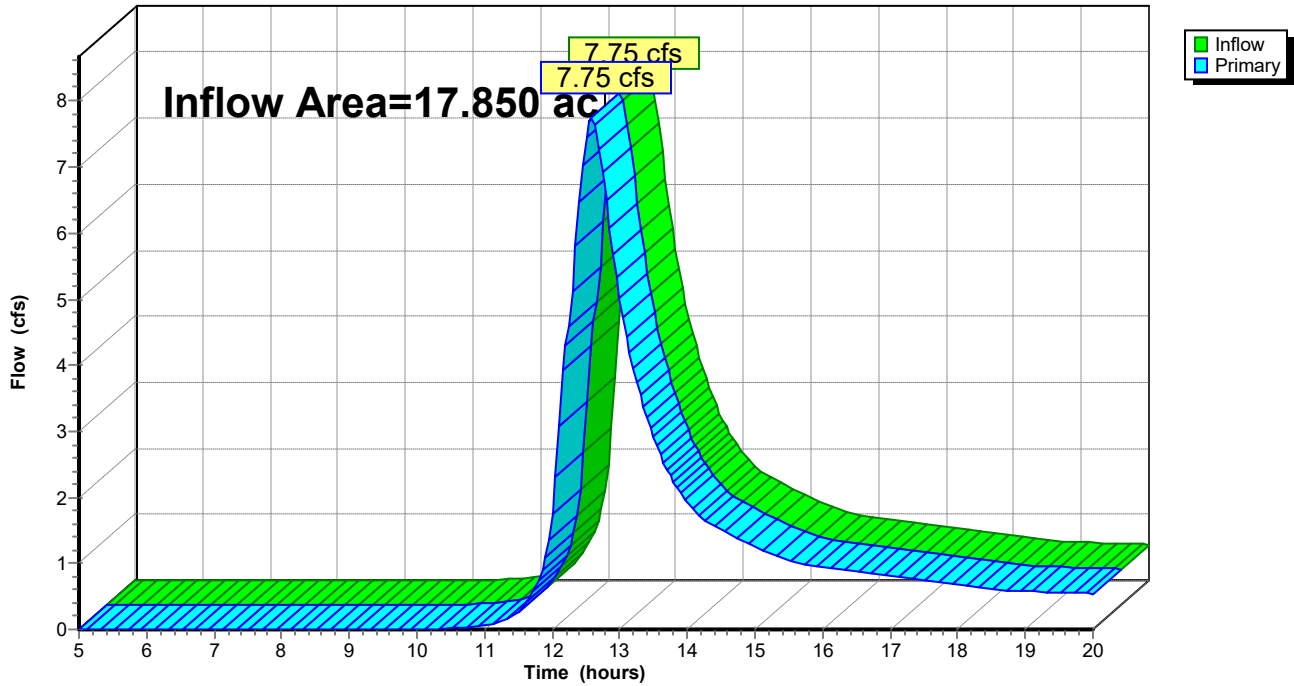

Summary for Link 18L: PR POA / B

Inflow Area = 6.180 ac, 0.00% Impervious, Inflow Depth > 0.57" for 2-Year event
Inflow = 3.09 cfs @ 12.25 hrs, Volume= 0.296 af
Primary = 3.09 cfs @ 12.25 hrs, Volume= 0.296 af, Atten= 0%, Lag= 0.0 min

Primary outflow = Inflow, Time Span= 5.00-20.00 hrs, dt= 0.05 hrs

Link 18L: PR POA / B

Hydrograph

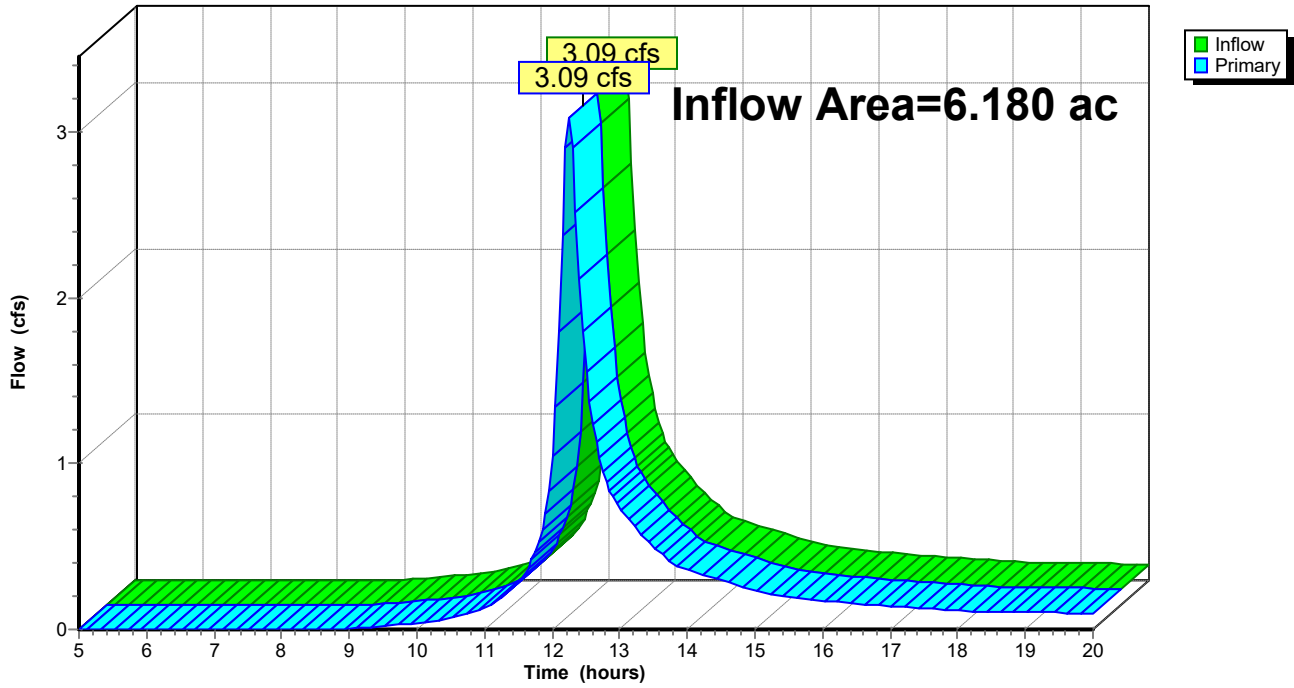

Summary for Subcatchment 1S: EXWS-10

Runoff = 4.01 cfs @ 12.23 hrs, Volume= 0.350 af, Depth> 1.71"
Routed to Link 4L : EX POA / A

Runoff by SCS TR-20 method, UH=SCS, Weighted-CN, Time Span= 5.00-20.00 hrs, dt= 0.05 hrs
NOAA 24-hr D 5-Year Rainfall=4.19"

Area (ac)	CN	Description
* 2.460	76	
2.460		100.00% Pervious Area

Tc (min)	Length (feet)	Slope (ft/ft)	Velocity (ft/sec)	Capacity (cfs)	Description
14.2					Direct Entry,

Subcatchment 1S: EXWS-10

Hydrograph

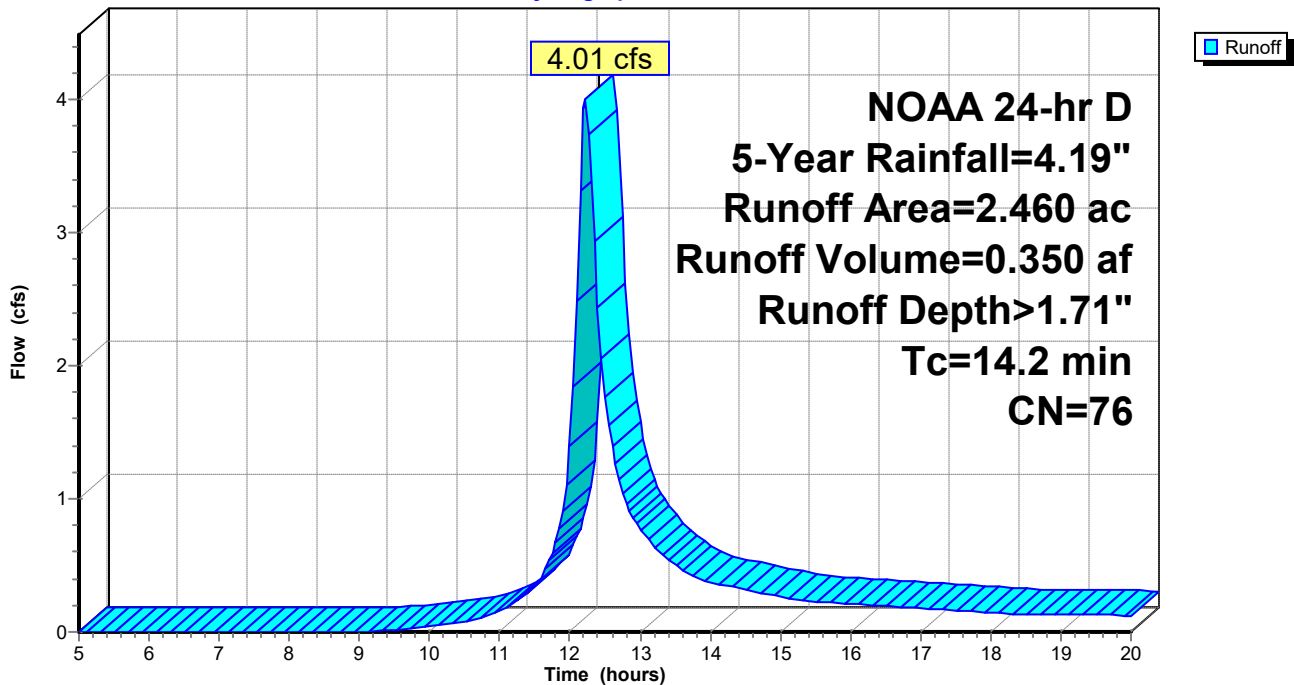

Summary for Subcatchment 2S: EXWS-11

Runoff = 13.97 cfs @ 12.57 hrs, Volume= 1.977 af, Depth> 1.48"
Routed to Link 4L : EX POA / A

Runoff by SCS TR-20 method, UH=SCS, Weighted-CN, Time Span= 5.00-20.00 hrs, dt= 0.05 hrs
NOAA 24-hr D 5-Year Rainfall=4.19"

Area (ac)	CN	Description
* 16.050	73	
16.050		100.00% Pervious Area

Tc (min)	Length (feet)	Slope (ft/ft)	Velocity (ft/sec)	Capacity (cfs)	Description
39.6					Direct Entry,

Subcatchment 2S: EXWS-11

Hydrograph

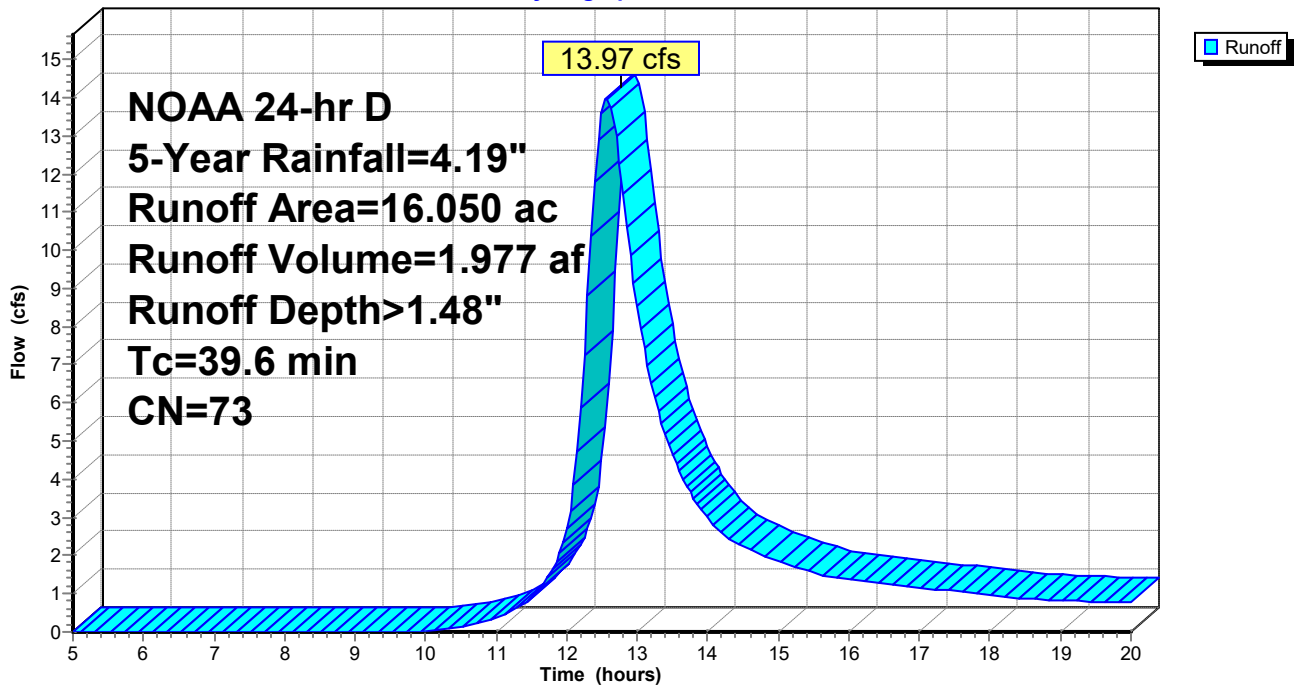

Summary for Subcatchment 5S: EXWS-20 / B

Runoff = 10.09 cfs @ 12.23 hrs, Volume= 0.903 af, Depth> 2.17"

Runoff by SCS TR-20 method, UH=SCS, Weighted-CN, Time Span= 5.00-20.00 hrs, dt= 0.05 hrs
NOAA 24-hr D 5-Year Rainfall=4.19"

Area (ac)	CN	Description
* 5.000	82	
5.000		100.00% Pervious Area

Tc (min)	Length (feet)	Slope (ft/ft)	Velocity (ft/sec)	Capacity (cfs)	Description
14.9					Direct Entry,

Subcatchment 5S: EXWS-20 / B

Hydrograph

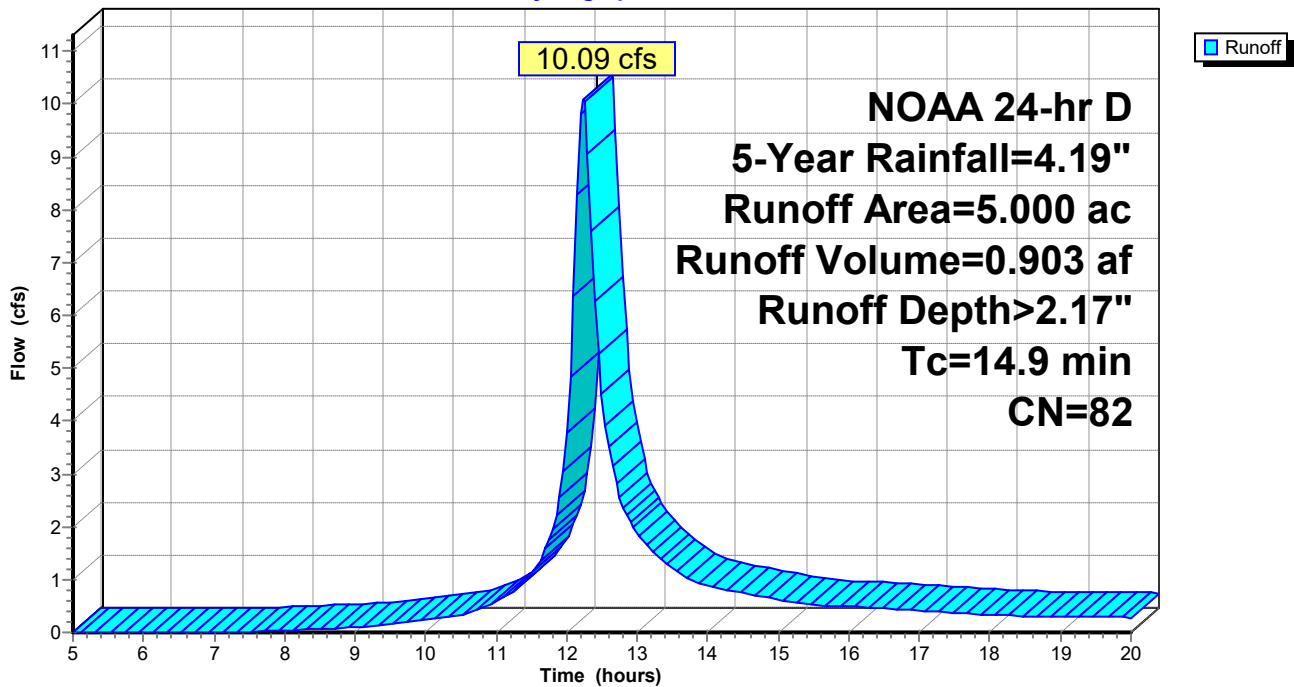

Summary for Subcatchment 6S: EXWS-30 / C

Runoff = 2.88 cfs @ 12.22 hrs, Volume= 0.248 af, Depth> 1.78"

Runoff by SCS TR-20 method, UH=SCS, Weighted-CN, Time Span= 5.00-20.00 hrs, dt= 0.05 hrs
NOAA 24-hr D 5-Year Rainfall=4.19"

Area (ac)	CN	Description
* 1.670	77	
1.670		100.00% Pervious Area

Tc (min)	Length (feet)	Slope (ft/ft)	Velocity (ft/sec)	Capacity (cfs)	Description
14.0					Direct Entry,

Subcatchment 6S: EXWS-30 / C

Hydrograph

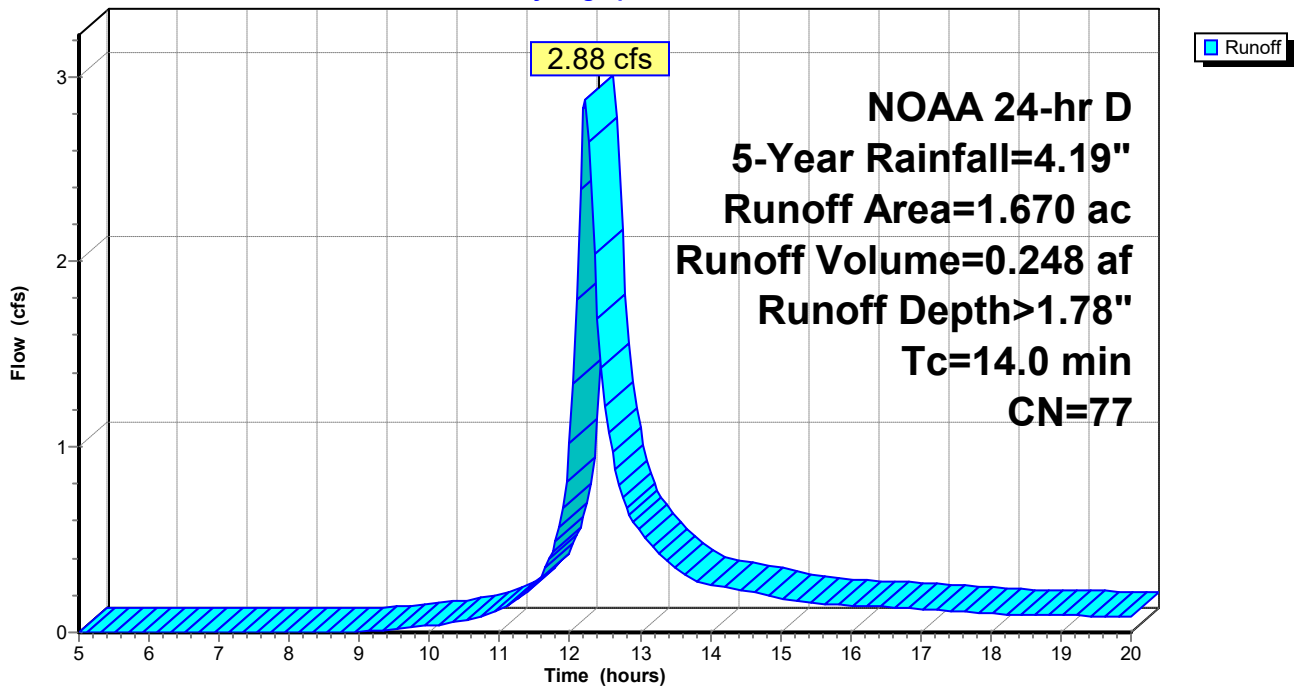

Summary for Subcatchment 7S: PRWS-10

Runoff = 3.48 cfs @ 12.15 hrs, Volume= 0.248 af, Depth> 1.86"
Routed to Link 15L : PR POA / A

Runoff by SCS TR-20 method, UH=SCS, Weighted-CN, Time Span= 5.00-20.00 hrs, dt= 0.05 hrs
NOAA 24-hr D 5-Year Rainfall=4.19"

Area (ac)	CN	Description
* 1.600	78	
1.600		100.00% Pervious Area

Tc (min)	Length (feet)	Slope (ft/ft)	Velocity (ft/sec)	Capacity (cfs)	Description
8.2					Direct Entry,

Subcatchment 7S: PRWS-10

Hydrograph

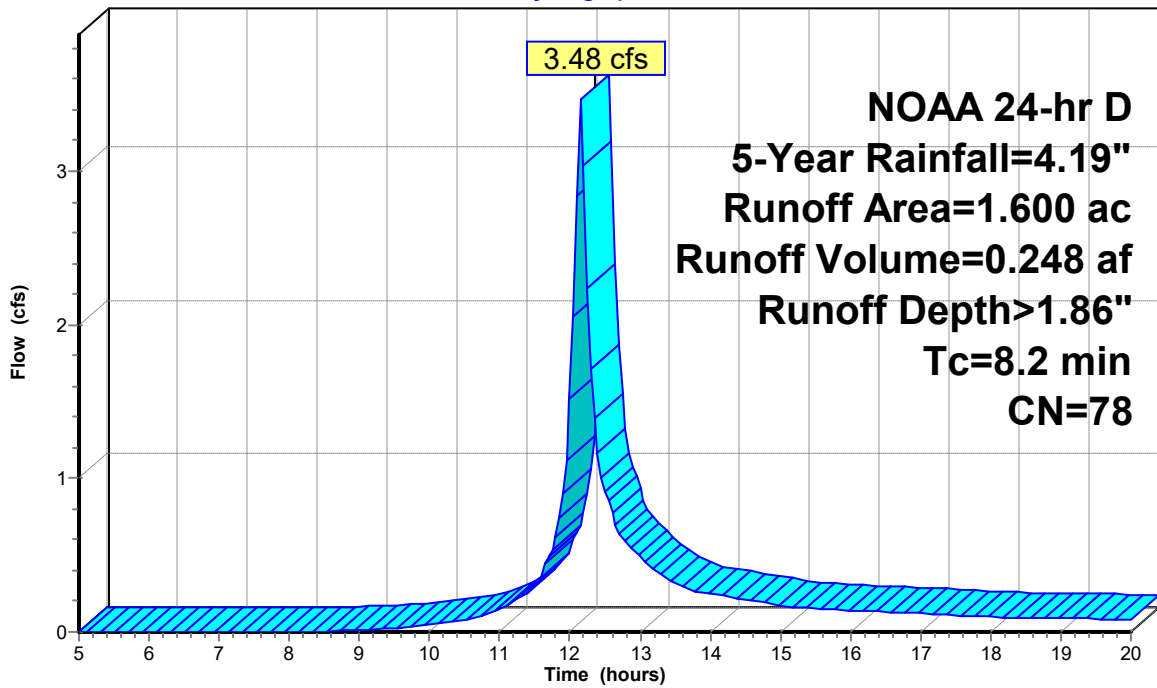

Summary for Subcatchment 8S: PRWS-11

Runoff = 13.88 cfs @ 12.57 hrs, Volume= 1.962 af, Depth> 1.48"
Routed to Link 15L : PR POA / A

Runoff by SCS TR-20 method, UH=SCS, Weighted-CN, Time Span= 5.00-20.00 hrs, dt= 0.05 hrs
NOAA 24-hr D 5-Year Rainfall=4.19"

Table with 3 columns: Area (ac), CN, Description. Row 1: 15.920, 73, 100.00% Pervious Area

Table with 7 columns: Tc (min), Length (feet), Slope (ft/ft), Velocity (ft/sec), Capacity (cfs), Description. Row 1: 39.5, Direct Entry,

Subcatchment 8S: PRWS-11

Hydrograph

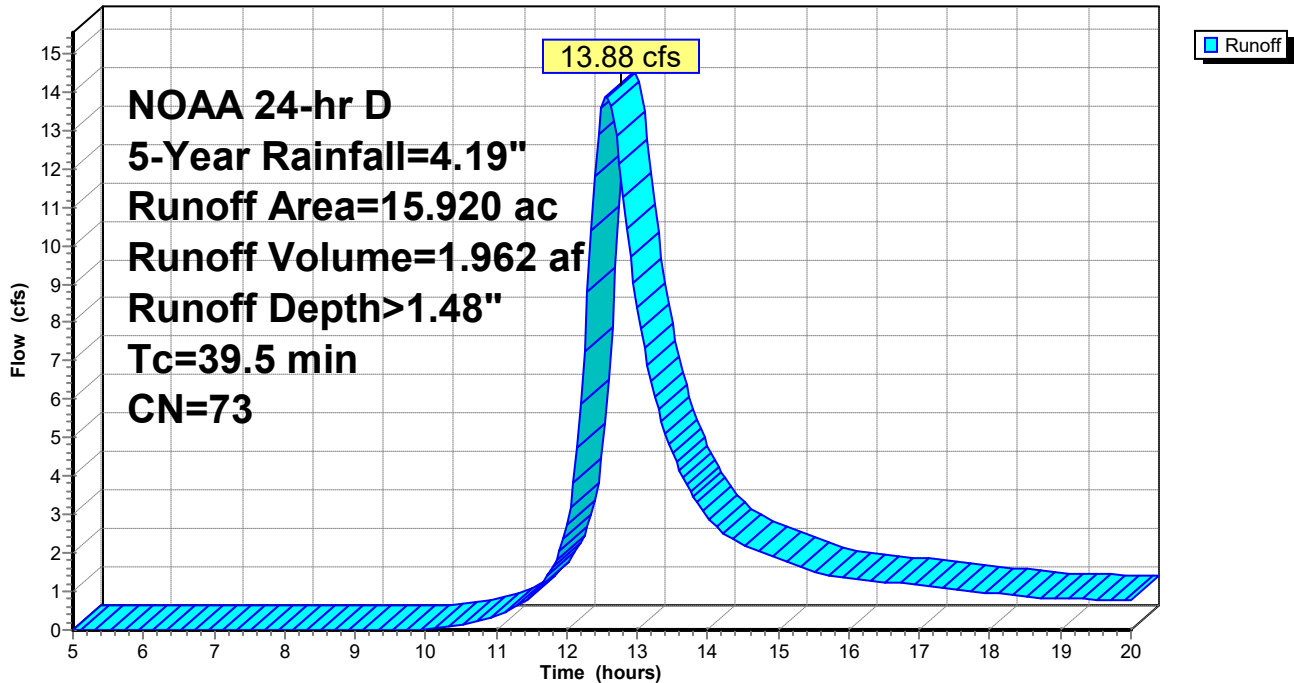

Summary for Subcatchment 10S: PRWS-20

Runoff = 5.08 cfs @ 12.25 hrs, Volume= 0.466 af, Depth> 2.17"
Routed to Link 18L : PR POA / B

Runoff by SCS TR-20 method, UH=SCS, Weighted-CN, Time Span= 5.00-20.00 hrs, dt= 0.05 hrs
NOAA 24-hr D 5-Year Rainfall=4.19"

Table with 3 columns: Area (ac), CN, Description. Row 1: 2.580, 82, 100.00% Pervious Area

Table with 7 columns: Tc (min), Length (feet), Slope (ft/ft), Velocity (ft/sec), Capacity (cfs), Description. Row 1: 15.9, Direct Entry,

Subcatchment 10S: PRWS-20

Hydrograph

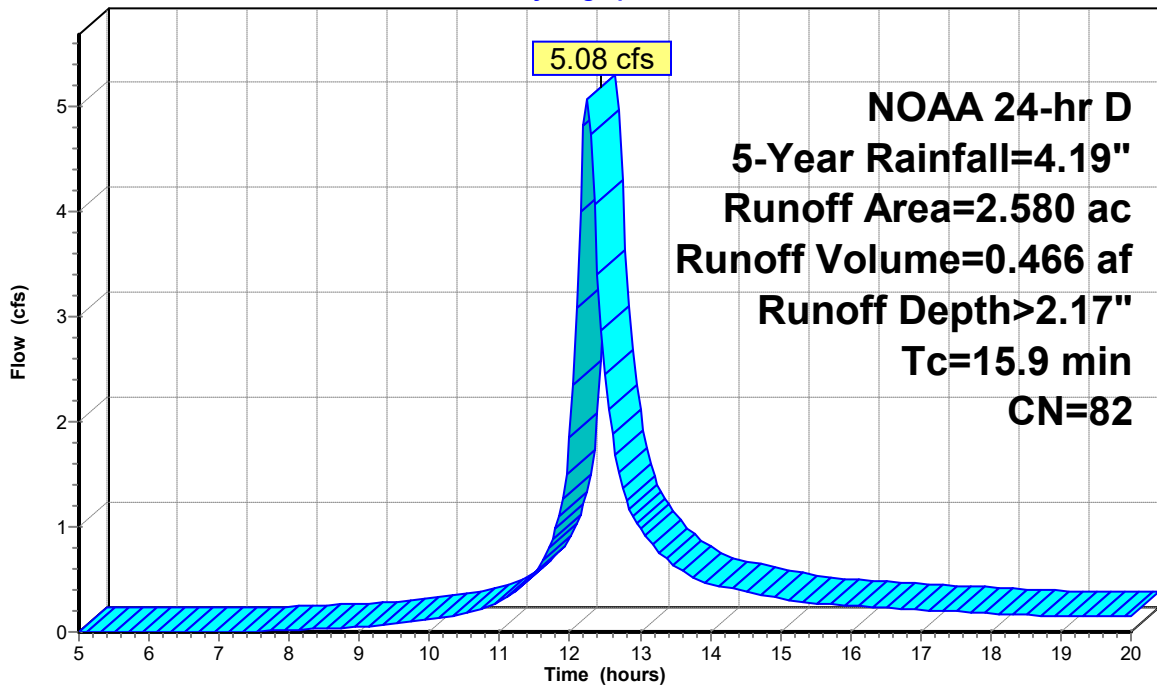

Runoff

Summary for Subcatchment 11S: PRWS-21

Runoff = 8.39 cfs @ 12.16 hrs, Volume= 0.660 af, Depth> 2.79"
Routed to Pond 16P : DET 210

Runoff by SCS TR-20 method, UH=SCS, Weighted-CN, Time Span= 5.00-20.00 hrs, dt= 0.05 hrs
NOAA 24-hr D 5-Year Rainfall=4.19"

Area (ac)	CN	Description
* 2.840	89	
2.840		100.00% Pervious Area

Tc (min)	Length (feet)	Slope (ft/ft)	Velocity (ft/sec)	Capacity (cfs)	Description
9.4					Direct Entry,

Subcatchment 11S: PRWS-21

Hydrograph

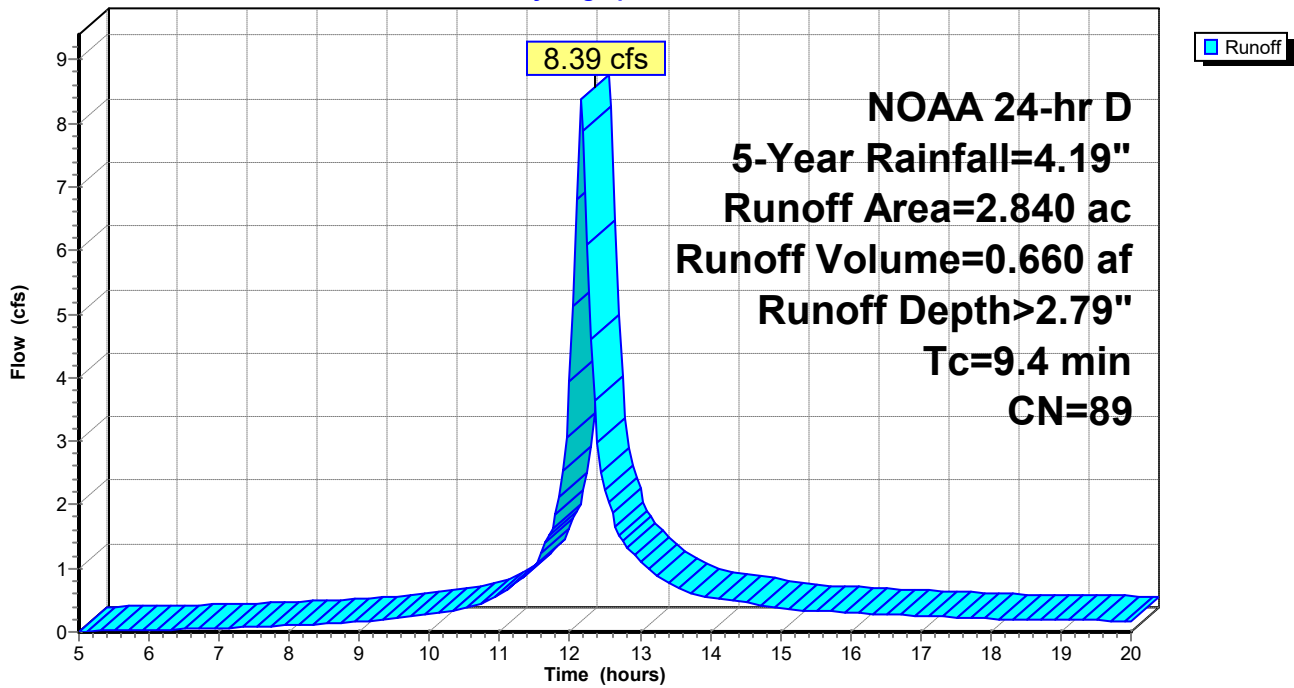

Summary for Subcatchment 12S: PRWS-22

Runoff = 2.28 cfs @ 12.17 hrs, Volume= 0.182 af, Depth> 2.88"
Routed to Pond 17P : DET 220

Runoff by SCS TR-20 method, UH=SCS, Weighted-CN, Time Span= 5.00-20.00 hrs, dt= 0.05 hrs
NOAA 24-hr D 5-Year Rainfall=4.19"

Area (ac)	CN	Description
* 0.760	90	
0.760		100.00% Pervious Area

Tc (min)	Length (feet)	Slope (ft/ft)	Velocity (ft/sec)	Capacity (cfs)	Description
9.7					Direct Entry,

Subcatchment 12S: PRWS-22

Hydrograph

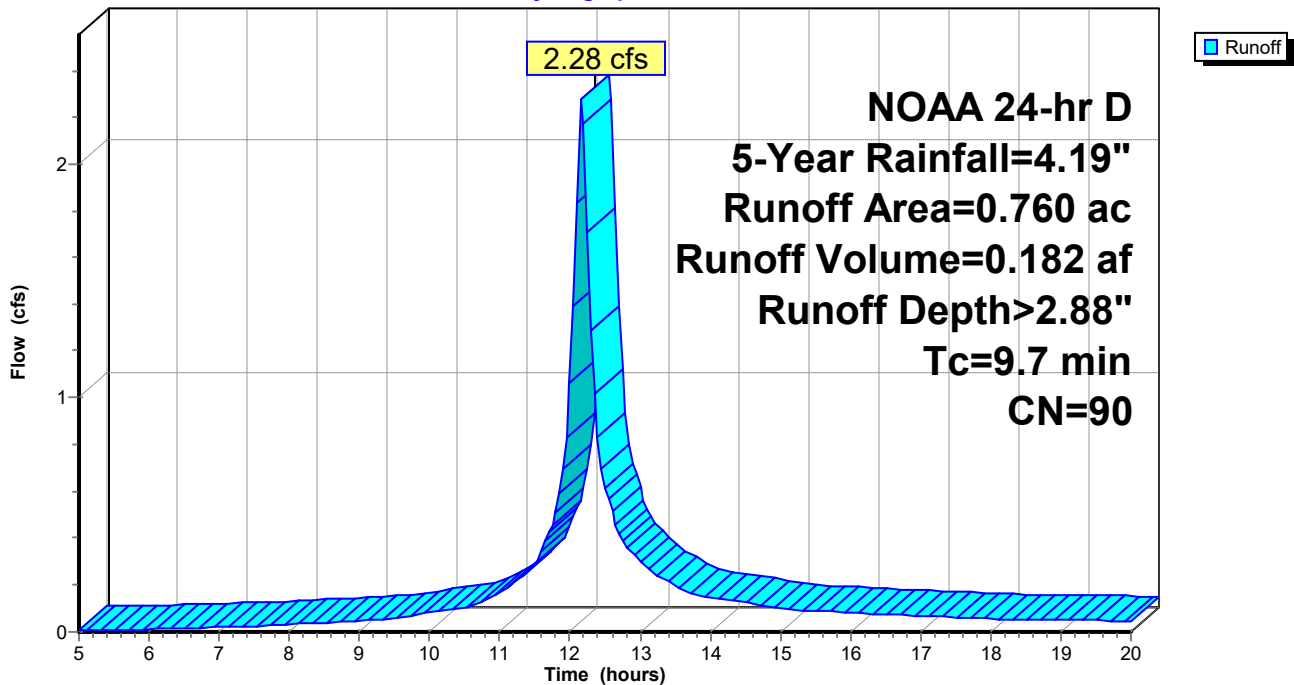

Summary for Subcatchment 13S: PRWS-30 / C

Runoff = 2.06 cfs @ 12.22 hrs, Volume= 0.175 af, Depth> 1.85"

Runoff by SCS TR-20 method, UH=SCS, Weighted-CN, Time Span= 5.00-20.00 hrs, dt= 0.05 hrs
NOAA 24-hr D 5-Year Rainfall=4.19"

Area (ac)	CN	Description
* 1.130	78	
1.130		100.00% Pervious Area

Tc (min)	Length (feet)	Slope (ft/ft)	Velocity (ft/sec)	Capacity (cfs)	Description
13.4					Direct Entry,

Subcatchment 13S: PRWS-30 / C

Hydrograph

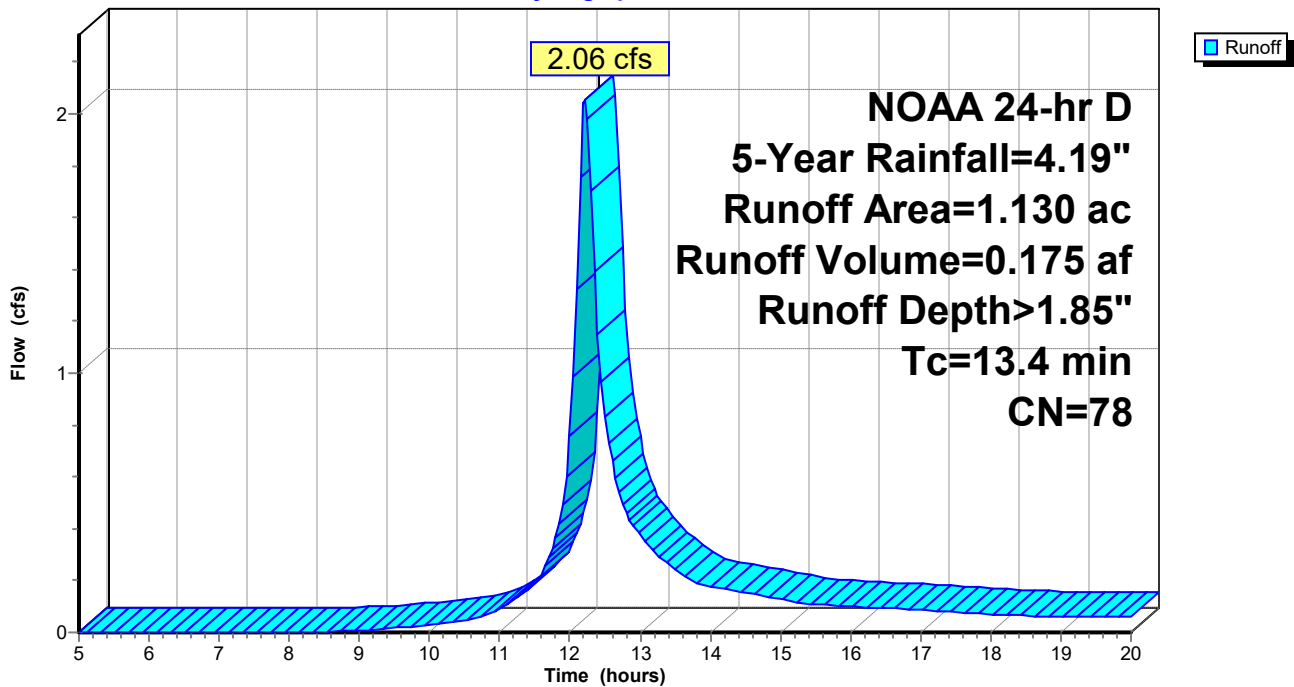

Summary for Subcatchment 20S: PRWS-14

Runoff = 0.93 cfs @ 12.15 hrs, Volume= 0.067 af, Depth> 2.43"
 Routed to Pond 23P : WQ 140

Runoff by SCS TR-20 method, UH=SCS, Weighted-CN, Time Span= 5.00-20.00 hrs, dt= 0.05 hrs
 NOAA 24-hr D 5-Year Rainfall=4.19"

Area (ac)	CN	Description
* 0.330	85	
0.330		100.00% Pervious Area

Tc (min)	Length (feet)	Slope (ft/ft)	Velocity (ft/sec)	Capacity (cfs)	Description
7.7					Direct Entry,

Subcatchment 20S: PRWS-14

Hydrograph

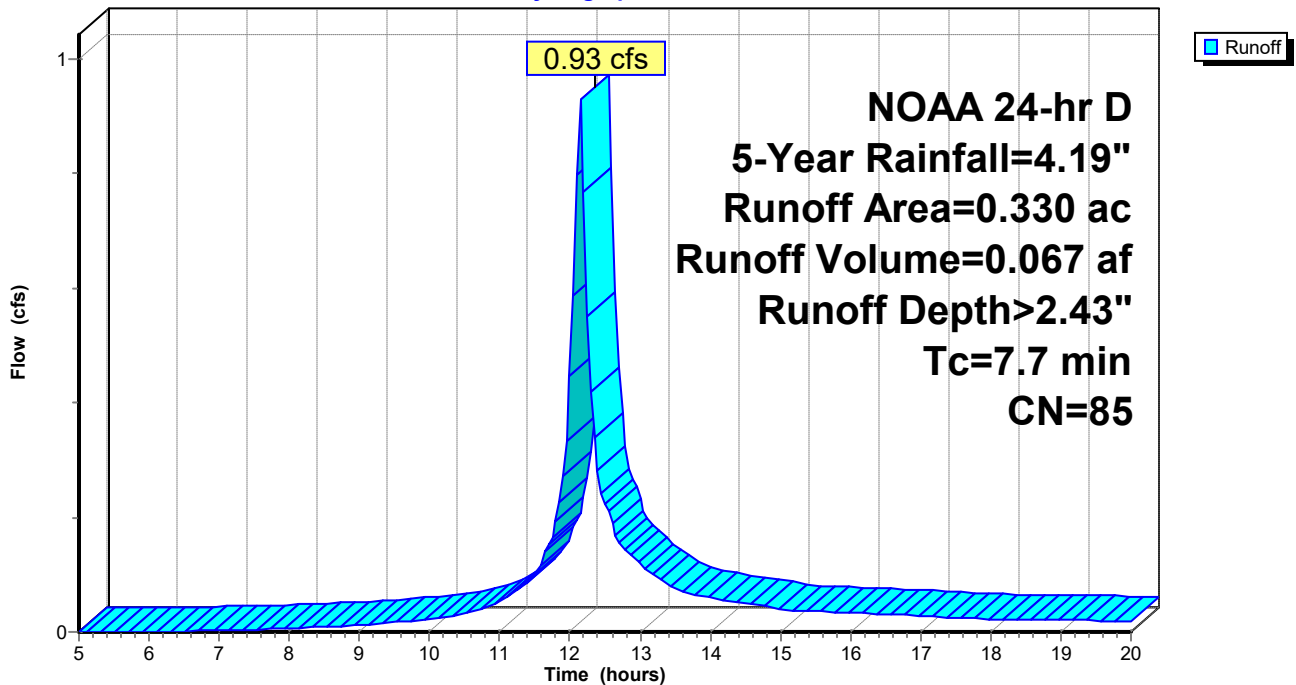

Summary for Pond 16P: DET 210

Inflow Area = 2.840 ac, 0.00% Impervious, Inflow Depth > 2.79" for 5-Year event
 Inflow = 8.39 cfs @ 12.16 hrs, Volume= 0.660 af
 Outflow = 3.80 cfs @ 12.35 hrs, Volume= 0.639 af, Atten= 55%, Lag= 11.3 min
 Discarded = 0.62 cfs @ 12.35 hrs, Volume= 0.503 af
 Primary = 3.18 cfs @ 12.35 hrs, Volume= 0.136 af
 Routed to Link 18L : PR POA / B
 Secondary = 0.00 cfs @ 5.00 hrs, Volume= 0.000 af
 Routed to Link 18L : PR POA / B

Routing by Stor-Ind method, Time Span= 5.00-20.00 hrs, dt= 0.05 hrs
 Peak Elev= 816.07' @ 12.35 hrs Surf.Area= 8,999 sf Storage= 8,898 cf

Plug-Flow detention time= 94.4 min calculated for 0.637 af (97% of inflow)
 Center-of-Mass det. time= 82.1 min (853.8 - 771.7)

Volume	Invert	Avail.Storage	Storage Description		
#1	815.00'	28,886 cf	Custom Stage Data (Conic) Listed below (Recalc)		
Elevation (feet)	Surf.Area (sq-ft)	Inc.Store (cubic-feet)	Cum.Store (cubic-feet)	Wet.Area (sq-ft)	
815.00	7,672	0	0	7,672	
816.00	8,907	8,282	8,282	8,948	
817.00	10,296	9,593	17,875	10,380	
818.00	11,741	11,011	28,886	11,872	

Device	Routing	Invert	Outlet Devices	
#1	Discarded	815.00'	3.000 in/hr Exfiltration over Surface area	
#2	Primary	814.50'	15.0" Round Culvert L= 127.0' CPP, projecting, no headwall, Ke= 0.900 Inlet / Outlet Invert= 814.50' / 806.40' S= 0.0638 '/' Cc= 0.900 n= 0.012, Flow Area= 1.23 sf	
#3	Device 2	815.90'	14.0' long Sharp-Crested Rectangular Weir 2 End Contraction(s)	
#4	Secondary	817.20'	10.0' long + 3.0 '/' SideZ x 8.0' breadth Broad-Crested Rectangular Weir Head (feet) 0.20 0.40 0.60 0.80 1.00 1.20 1.40 1.60 1.80 2.00 2.50 3.00 3.50 4.00 4.50 5.00 5.50 Coef. (English) 2.43 2.54 2.70 2.69 2.68 2.68 2.66 2.64 2.64 2.64 2.65 2.65 2.66 2.66 2.68 2.70 2.74	

Discarded OutFlow Max=0.62 cfs @ 12.35 hrs HW=816.07' (Free Discharge)
 ↑1=Exfiltration (Exfiltration Controls 0.62 cfs)

Primary OutFlow Max=3.16 cfs @ 12.35 hrs HW=816.07' (Free Discharge)
 ↑2=Culvert (Passes 3.16 cfs of 4.53 cfs potential flow)
 ↑3=Sharp-Crested Rectangular Weir (Weir Controls 3.16 cfs @ 1.34 fps)

Secondary OutFlow Max=0.00 cfs @ 5.00 hrs HW=815.00' (Free Discharge)
 ↑4=Broad-Crested Rectangular Weir (Controls 0.00 cfs)

Pond 16P: DET 210

Hydrograph

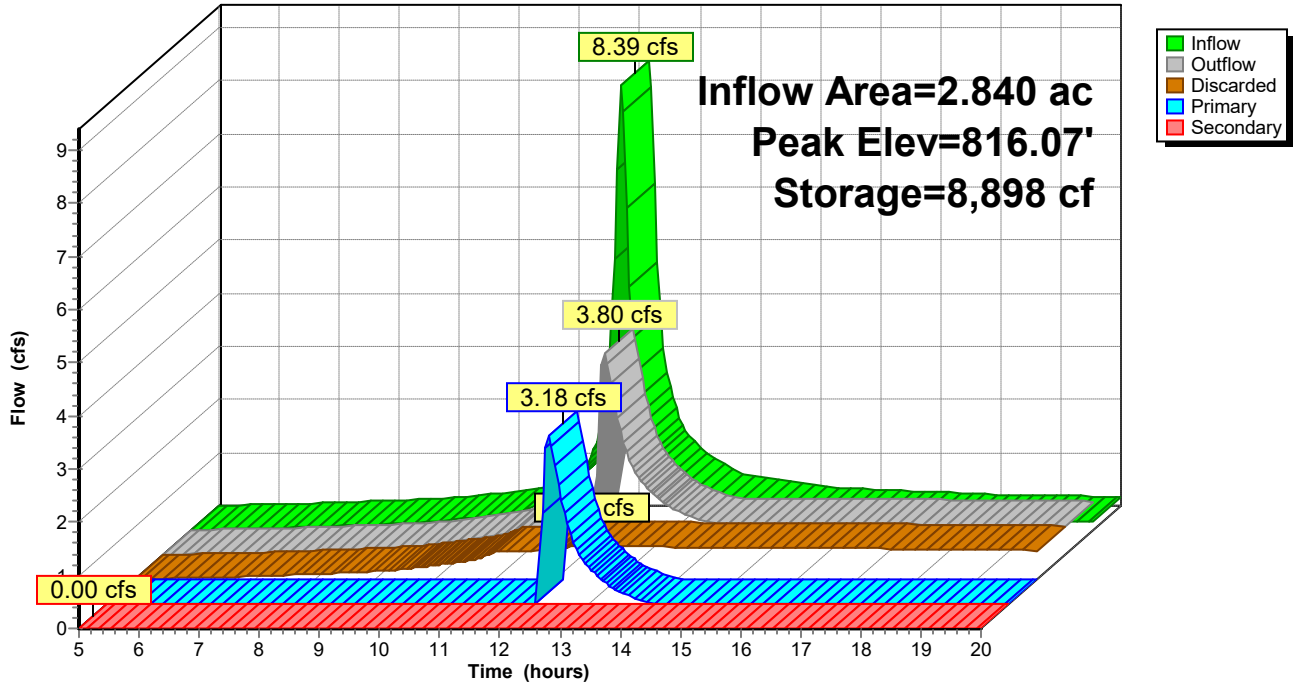

Summary for Pond 17P: DET 220

Inflow Area = 0.760 ac, 0.00% Impervious, Inflow Depth > 2.88" for 5-Year event
 Inflow = 2.28 cfs @ 12.17 hrs, Volume= 0.182 af
 Outflow = 0.57 cfs @ 12.54 hrs, Volume= 0.137 af, Atten= 75%, Lag= 22.5 min
 Discarded = 0.09 cfs @ 12.54 hrs, Volume= 0.075 af
 Primary = 0.48 cfs @ 12.54 hrs, Volume= 0.062 af
 Routed to Link 18L : PR POA / B
 Secondary = 0.00 cfs @ 5.00 hrs, Volume= 0.000 af
 Routed to Link 18L : PR POA / B

Routing by Stor-Ind method, Time Span= 5.00-20.00 hrs, dt= 0.05 hrs
 Peak Elev= 802.71' @ 12.54 hrs Surf.Area= 2,571 sf Storage= 3,352 cf

Plug-Flow detention time= 125.3 min calculated for 0.137 af (75% of inflow)
 Center-of-Mass det. time= 62.5 min (831.0 - 768.5)

Volume	Invert	Avail.Storage	Storage Description		
#1	801.00'	7,722 cf	Custom Stage Data (Conic) Listed below (Recalc)		
Elevation (feet)	Surf.Area (sq-ft)	Inc.Store (cubic-feet)	Cum.Store (cubic-feet)	Wet.Area (sq-ft)	
801.00	1,433	0	0	1,433	
802.00	2,039	1,727	1,727	2,057	
803.00	2,810	2,414	4,141	2,847	
804.00	4,412	3,581	7,722	4,463	

Device	Routing	Invert	Outlet Devices
#1	Discarded	801.00'	1.580 in/hr Exfiltration over Surface area
#2	Primary	800.50'	15.0" Round Culvert L= 39.0' CPP, projecting, no headwall, Ke= 0.900 Inlet / Outlet Invert= 800.50' / 800.00' S= 0.0128 '/' Cc= 0.900 n= 0.012, Flow Area= 1.23 sf
#3	Device 2	802.20'	6.0" Vert. Orifice/Grate C= 0.600 Limited to weir flow at low heads
#4	Device 2	802.80'	14.0' long Sharp-Crested Rectangular Weir 2 End Contraction(s)
#5	Secondary	803.00'	10.0' long + 3.0 ' SideZ x 8.0' breadth Broad-Crested Rectangular Weir Head (feet) 0.20 0.40 0.60 0.80 1.00 1.20 1.40 1.60 1.80 2.00 2.50 3.00 3.50 4.00 4.50 5.00 5.50 Coef. (English) 2.43 2.54 2.70 2.69 2.68 2.68 2.66 2.64 2.64 2.64 2.65 2.65 2.66 2.66 2.68 2.70 2.74

Discarded OutFlow Max=0.09 cfs @ 12.54 hrs HW=802.71' (Free Discharge)
 ↑1=Exfiltration (Exfiltration Controls 0.09 cfs)

Primary OutFlow Max=0.48 cfs @ 12.54 hrs HW=802.71' (Free Discharge)
 ↑2=Culvert (Passes 0.48 cfs of 5.87 cfs potential flow)
 ↑3=Orifice/Grate (Orifice Controls 0.48 cfs @ 2.44 fps)
 ↑4=Sharp-Crested Rectangular Weir (Controls 0.00 cfs)

Secondary OutFlow Max=0.00 cfs @ 5.00 hrs HW=801.00' (Free Discharge)
 ↑5=Broad-Crested Rectangular Weir (Controls 0.00 cfs)

Pond 17P: DET 220

Hydrograph

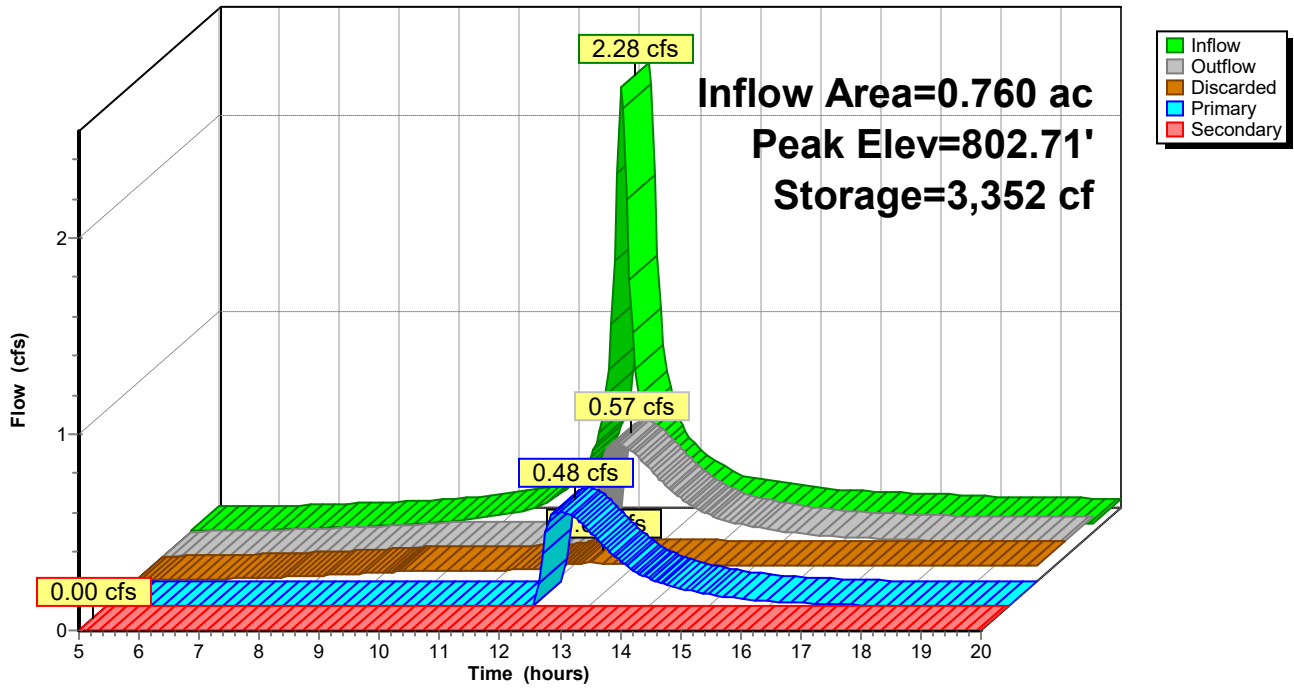

Summary for Pond 23P: WQ 140

Inflow Area = 0.330 ac, 0.00% Impervious, Inflow Depth > 2.43" for 5-Year event
 Inflow = 0.93 cfs @ 12.15 hrs, Volume= 0.067 af
 Outflow = 0.83 cfs @ 12.21 hrs, Volume= 0.044 af, Atten= 10%, Lag= 3.6 min
 Primary = 0.83 cfs @ 12.21 hrs, Volume= 0.044 af
 Routed to Link 15L : PR POA / A

Routing by Stor-Ind method, Time Span= 5.00-20.00 hrs, dt= 0.05 hrs
 Peak Elev= 838.60' @ 12.21 hrs Surf.Area= 1,155 sf Storage= 1,087 cf

Plug-Flow detention time= 128.1 min calculated for 0.044 af (66% of inflow)
 Center-of-Mass det. time= 55.5 min (838.7 - 783.2)

Volume	Invert	Avail.Storage	Storage Description
#1	837.50'	1,554 cf	Custom Stage Data (Prismatic) Listed below (Recalc)
Elevation (feet)	Surf.Area (sq-ft)	Inc.Store (cubic-feet)	Cum.Store (cubic-feet)
837.50	801	0	0
838.00	964	441	441
838.50	1,143	527	968
839.00	1,200	586	1,554

Device	Routing	Invert	Outlet Devices
#1	Primary	838.50'	10.0' long + 3.0 ' SideZ x 8.0' breadth Broad-Crested Rectangular Weir Head (feet) 0.20 0.40 0.60 0.80 1.00 1.20 1.40 1.60 1.80 2.00 2.50 3.00 3.50 4.00 4.50 5.00 5.50 Coef. (English) 2.43 2.54 2.70 2.69 2.68 2.68 2.66 2.64 2.64 2.64 2.65 2.65 2.66 2.66 2.68 2.70 2.74

Primary OutFlow Max=0.80 cfs @ 12.21 hrs HW=838.60' (Free Discharge)
 ↑1=**Broad-Crested Rectangular Weir** (Weir Controls 0.80 cfs @ 0.77 fps)

Pond 23P: WQ 140

Hydrograph

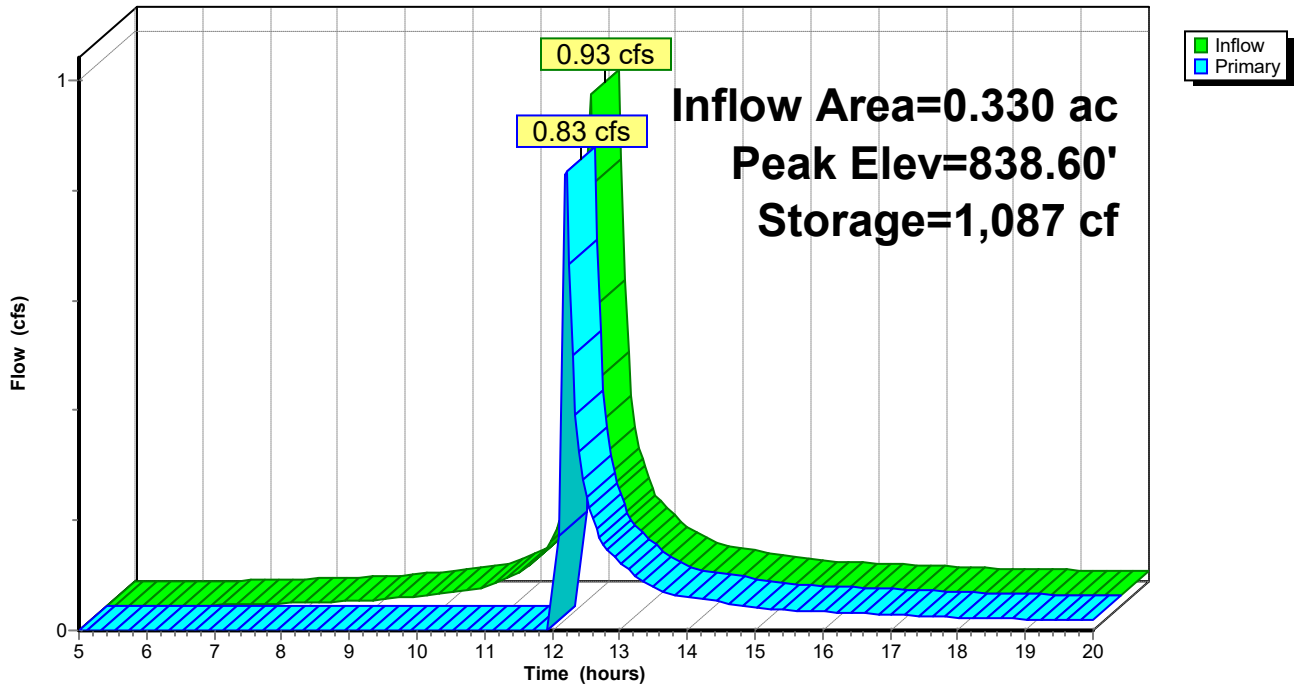

Summary for Link 4L: EX POA / A

Inflow Area = 18.510 ac, 0.00% Impervious, Inflow Depth > 1.51" for 5-Year event
Inflow = 15.50 cfs @ 12.55 hrs, Volume= 2.327 af
Primary = 15.50 cfs @ 12.55 hrs, Volume= 2.327 af, Atten= 0%, Lag= 0.0 min

Primary outflow = Inflow, Time Span= 5.00-20.00 hrs, dt= 0.05 hrs

Link 4L: EX POA / A

Hydrograph

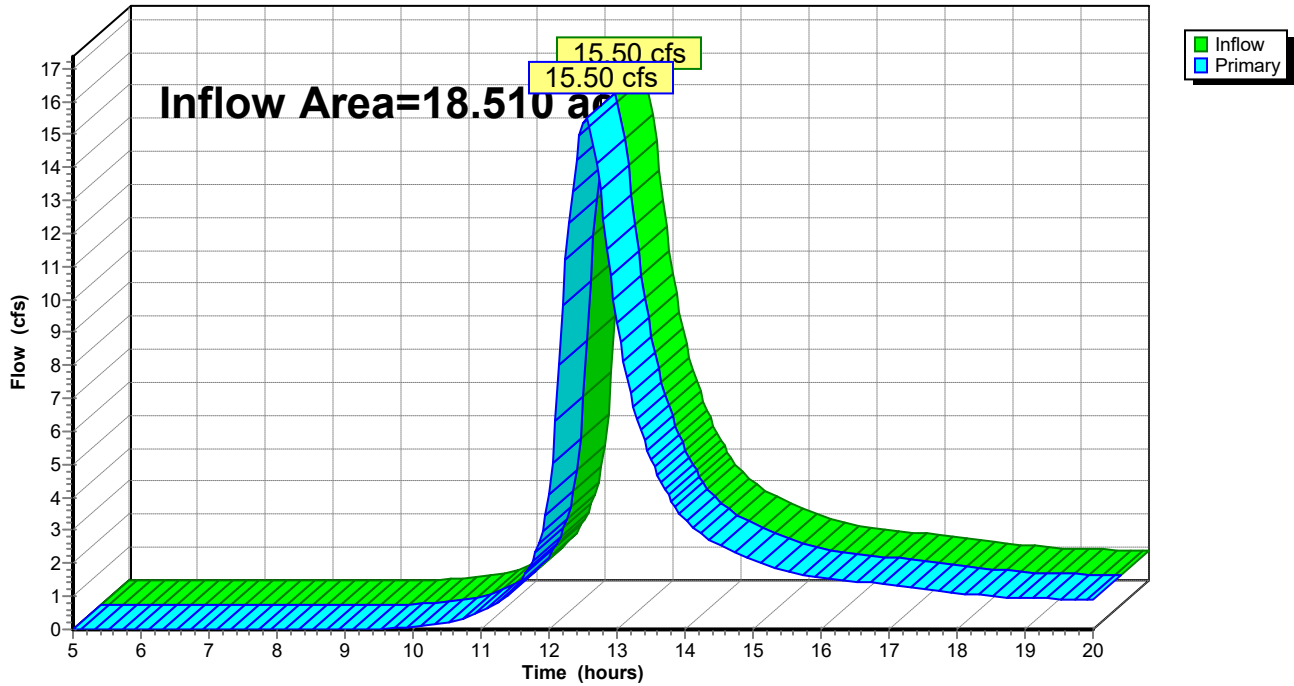

Summary for Link 15L: PR POA / A

Inflow Area = 17.850 ac, 0.00% Impervious, Inflow Depth > 1.51" for 5-Year event
Inflow = 14.94 cfs @ 12.55 hrs, Volume= 2.254 af
Primary = 14.94 cfs @ 12.55 hrs, Volume= 2.254 af, Atten= 0%, Lag= 0.0 min

Primary outflow = Inflow, Time Span= 5.00-20.00 hrs, dt= 0.05 hrs

Link 15L: PR POA / A

Hydrograph

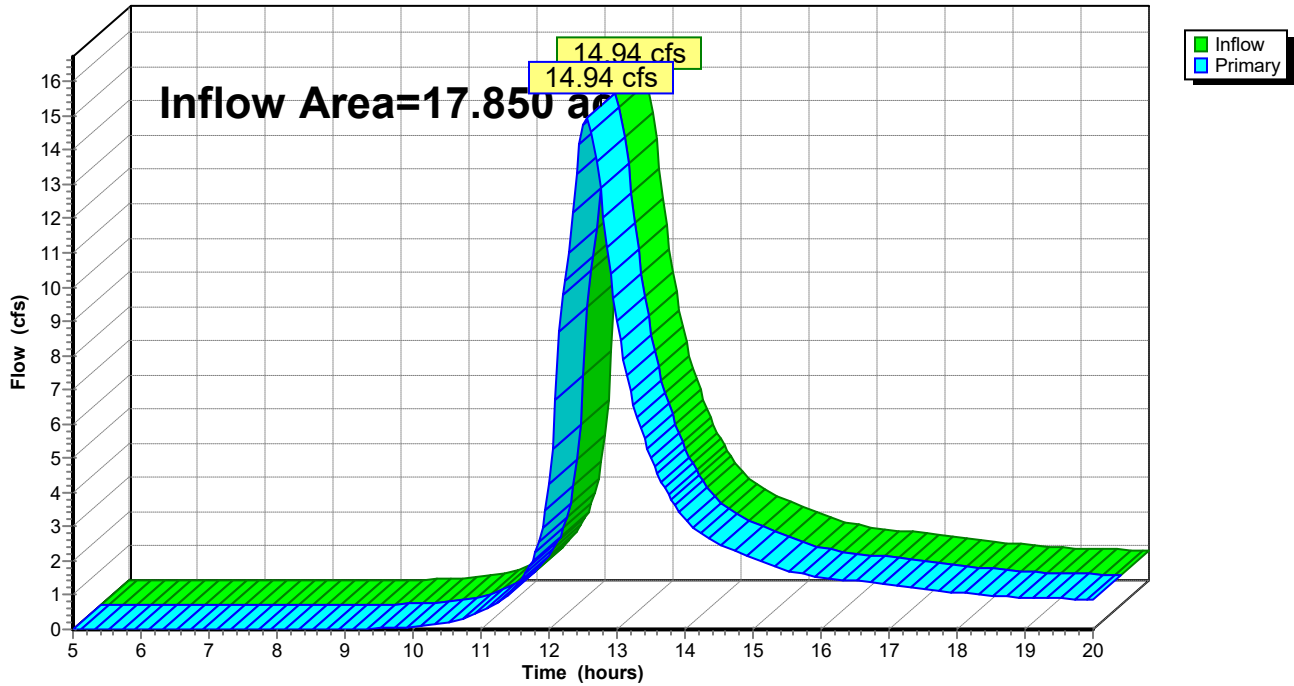

Summary for Link 18L: PR POA / B

Inflow Area = 6.180 ac, 0.00% Impervious, Inflow Depth > 1.29" for 5-Year event
Inflow = 8.09 cfs @ 12.31 hrs, Volume= 0.663 af
Primary = 8.09 cfs @ 12.31 hrs, Volume= 0.663 af, Atten= 0%, Lag= 0.0 min

Primary outflow = Inflow, Time Span= 5.00-20.00 hrs, dt= 0.05 hrs

Link 18L: PR POA / B

Hydrograph

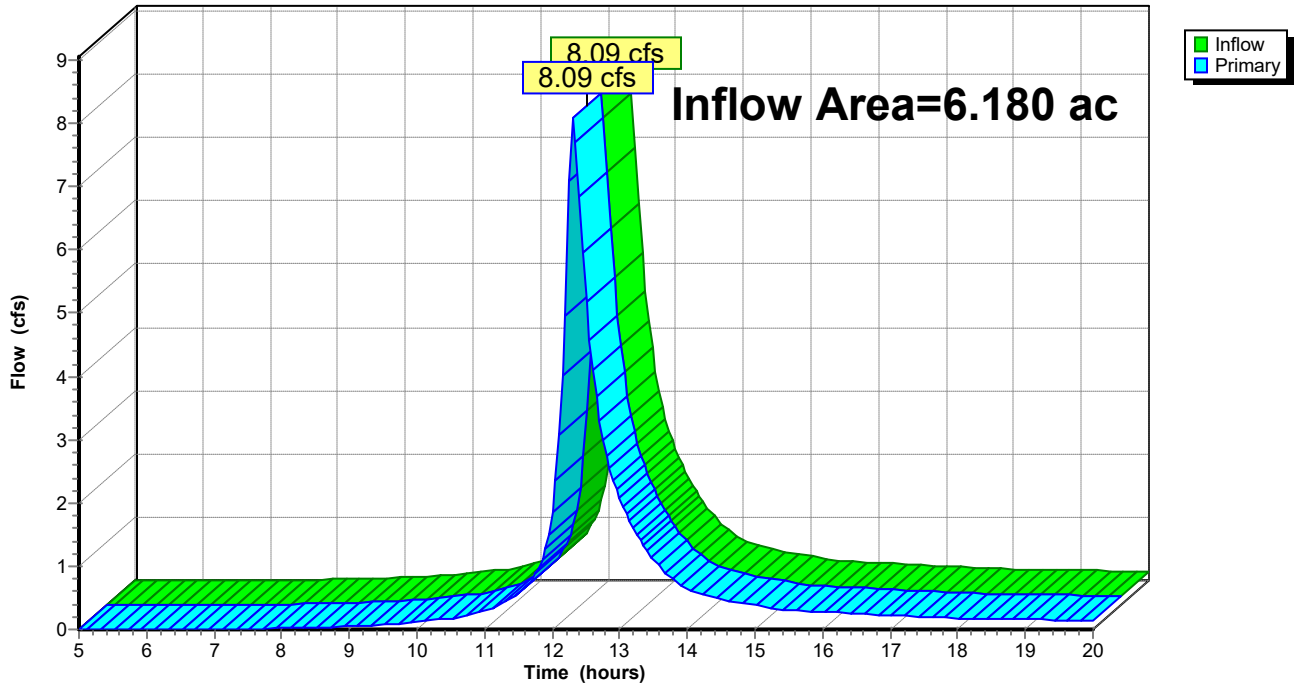

Summary for Subcatchment 1S: EXWS-10

Runoff = 5.62 cfs @ 12.23 hrs, Volume= 0.491 af, Depth> 2.39"
Routed to Link 4L : EX POA / A

Runoff by SCS TR-20 method, UH=SCS, Weighted-CN, Time Span= 5.00-20.00 hrs, dt= 0.05 hrs
NOAA 24-hr D 10-Year Rainfall=5.11"

Table with 3 columns: Area (ac), CN, Description. Row 1: 2.460, 76, 100.00% Pervious Area.

Table with 7 columns: Tc (min), Length (feet), Slope (ft/ft), Velocity (ft/sec), Capacity (cfs), Description. Row 1: 14.2, Direct Entry,

Subcatchment 1S: EXWS-10

Hydrograph

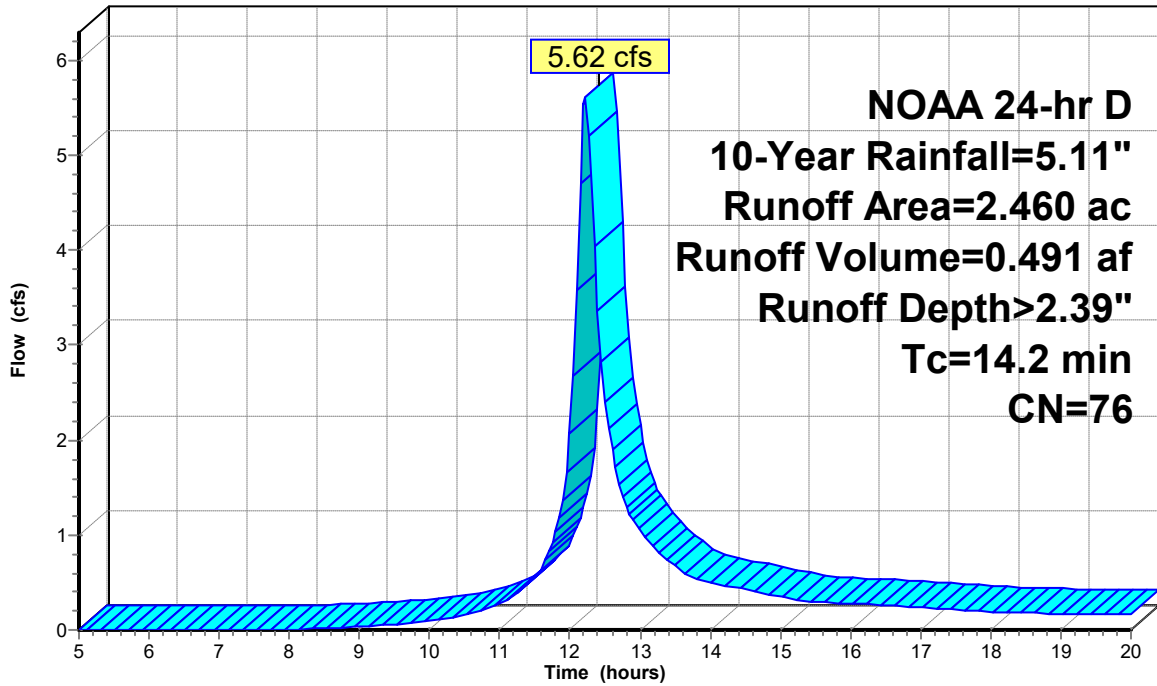

Runoff

Summary for Subcatchment 2S: EXWS-11

Runoff = 20.20 cfs @ 12.56 hrs, Volume= 2.836 af, Depth> 2.12"
Routed to Link 4L : EX POA / A

Runoff by SCS TR-20 method, UH=SCS, Weighted-CN, Time Span= 5.00-20.00 hrs, dt= 0.05 hrs
NOAA 24-hr D 10-Year Rainfall=5.11"

Area (ac)	CN	Description
* 16.050	73	
16.050		100.00% Pervious Area

Tc (min)	Length (feet)	Slope (ft/ft)	Velocity (ft/sec)	Capacity (cfs)	Description
39.6					Direct Entry,

Subcatchment 2S: EXWS-11

Hydrograph

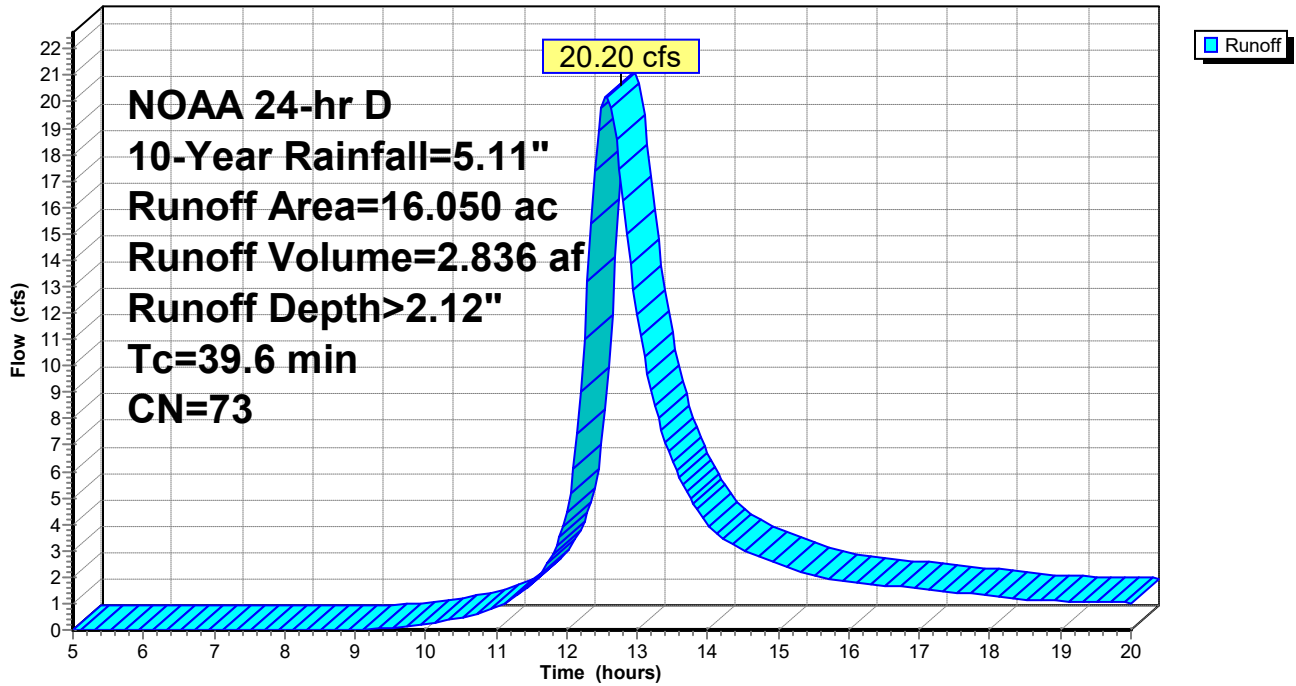

Summary for Subcatchment 5S: EXWS-20 / B

Runoff = 13.49 cfs @ 12.23 hrs, Volume= 1.218 af, Depth> 2.92"

Runoff by SCS TR-20 method, UH=SCS, Weighted-CN, Time Span= 5.00-20.00 hrs, dt= 0.05 hrs
NOAA 24-hr D 10-Year Rainfall=5.11"

Area (ac)	CN	Description
* 5.000	82	
5.000		100.00% Pervious Area

Tc (min)	Length (feet)	Slope (ft/ft)	Velocity (ft/sec)	Capacity (cfs)	Description
14.9					Direct Entry,

Subcatchment 5S: EXWS-20 / B

Hydrograph

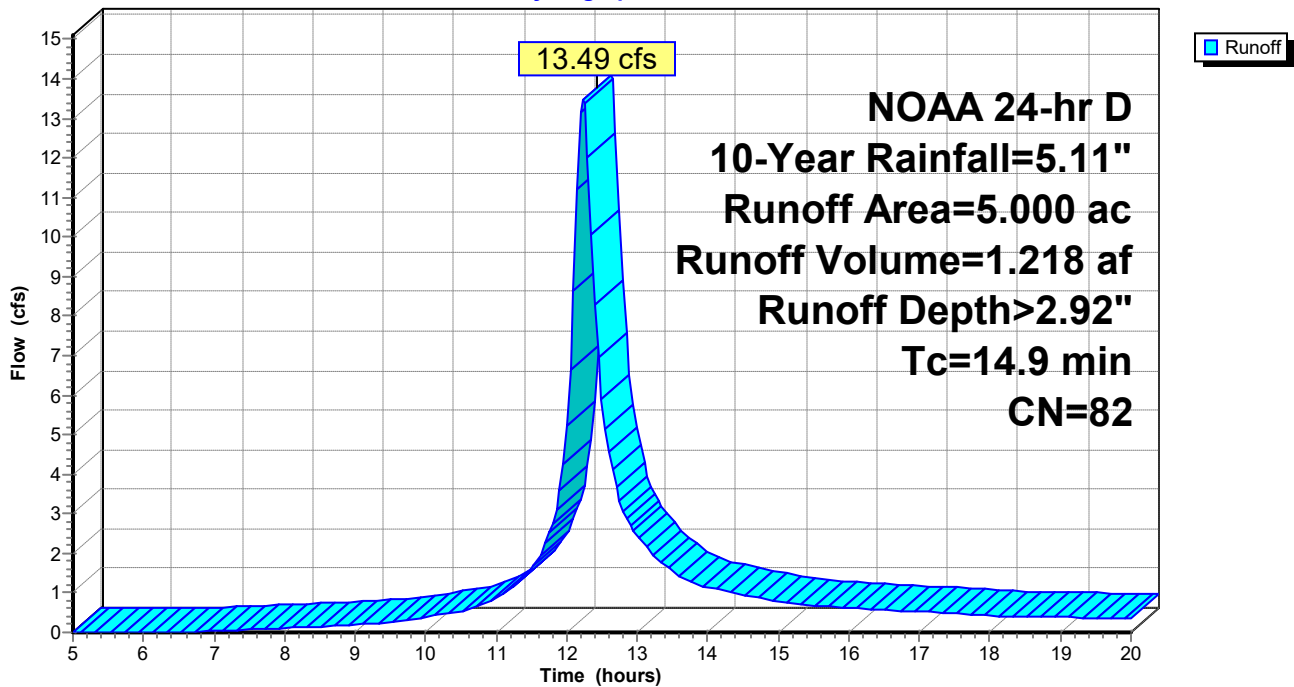

Summary for Subcatchment 6S: EXWS-30 / C

Runoff = 4.00 cfs @ 12.22 hrs, Volume= 0.345 af, Depth> 2.48"

Runoff by SCS TR-20 method, UH=SCS, Weighted-CN, Time Span= 5.00-20.00 hrs, dt= 0.05 hrs
NOAA 24-hr D 10-Year Rainfall=5.11"

Area (ac)	CN	Description
* 1.670	77	
1.670		100.00% Pervious Area

Tc (min)	Length (feet)	Slope (ft/ft)	Velocity (ft/sec)	Capacity (cfs)	Description
14.0					Direct Entry,

Subcatchment 6S: EXWS-30 / C

Hydrograph

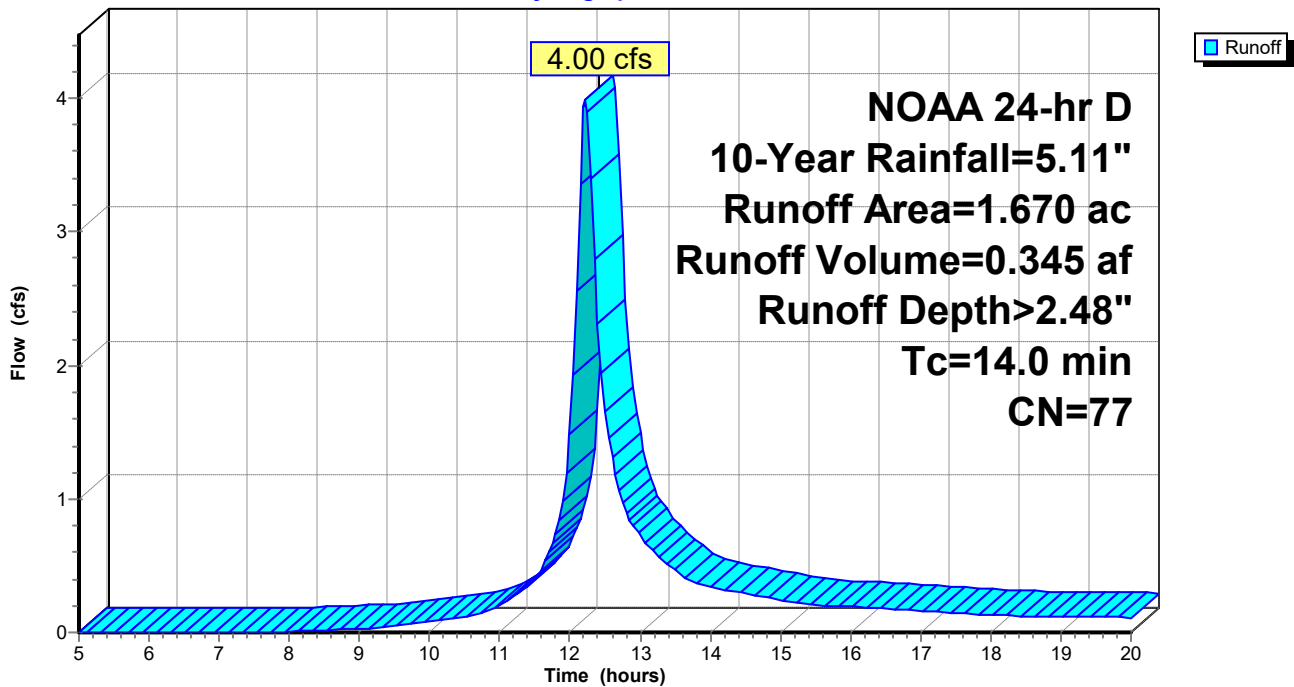

Summary for Subcatchment 7S: PRWS-10

Runoff = 4.78 cfs @ 12.15 hrs, Volume= 0.343 af, Depth> 2.57"
Routed to Link 15L : PR POA / A

Runoff by SCS TR-20 method, UH=SCS, Weighted-CN, Time Span= 5.00-20.00 hrs, dt= 0.05 hrs
NOAA 24-hr D 10-Year Rainfall=5.11"

Area (ac)	CN	Description
* 1.600	78	
1.600		100.00% Pervious Area

Tc (min)	Length (feet)	Slope (ft/ft)	Velocity (ft/sec)	Capacity (cfs)	Description
8.2					Direct Entry,

Subcatchment 7S: PRWS-10

Hydrograph

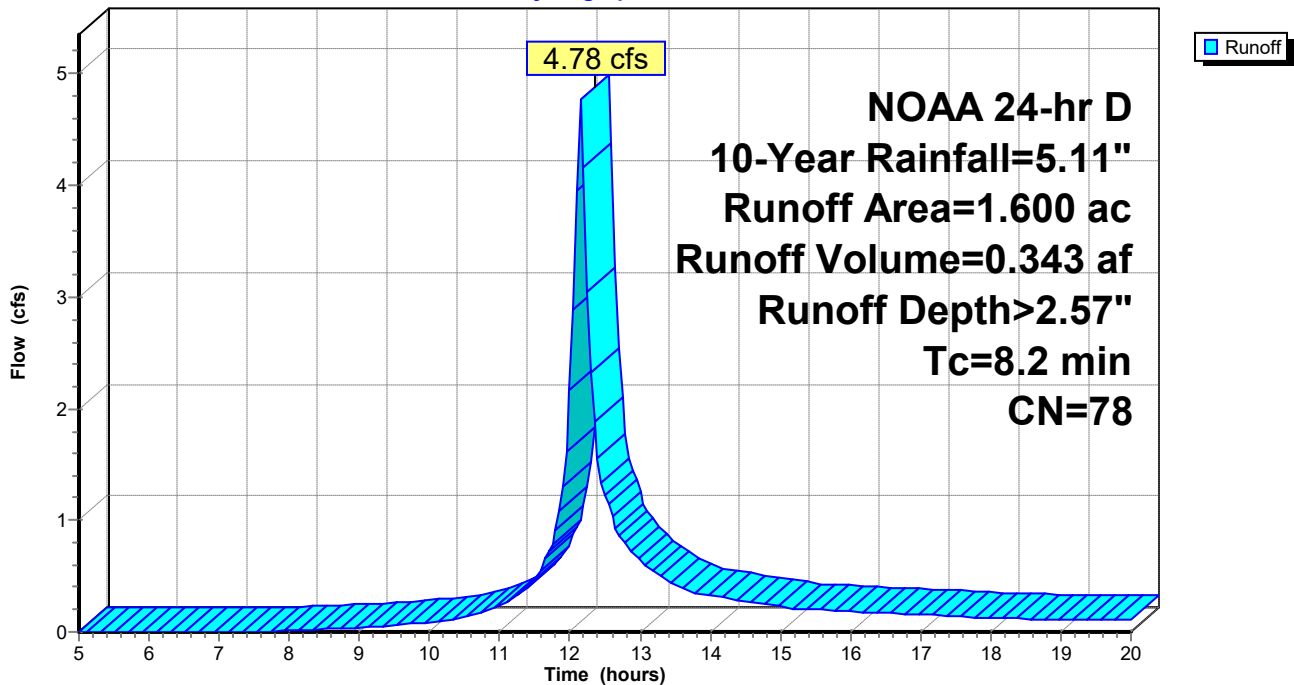

Summary for Subcatchment 8S: PRWS-11

Runoff = 20.05 cfs @ 12.56 hrs, Volume= 2.814 af, Depth> 2.12"
Routed to Link 15L : PR POA / A

Runoff by SCS TR-20 method, UH=SCS, Weighted-CN, Time Span= 5.00-20.00 hrs, dt= 0.05 hrs
NOAA 24-hr D 10-Year Rainfall=5.11"

Table with 3 columns: Area (ac), CN, Description. Row 1: 15.920, 73, 100.00% Pervious Area

Table with 7 columns: Tc (min), Length (feet), Slope (ft/ft), Velocity (ft/sec), Capacity (cfs), Description. Row 1: 39.5, Direct Entry,

Subcatchment 8S: PRWS-11

Hydrograph

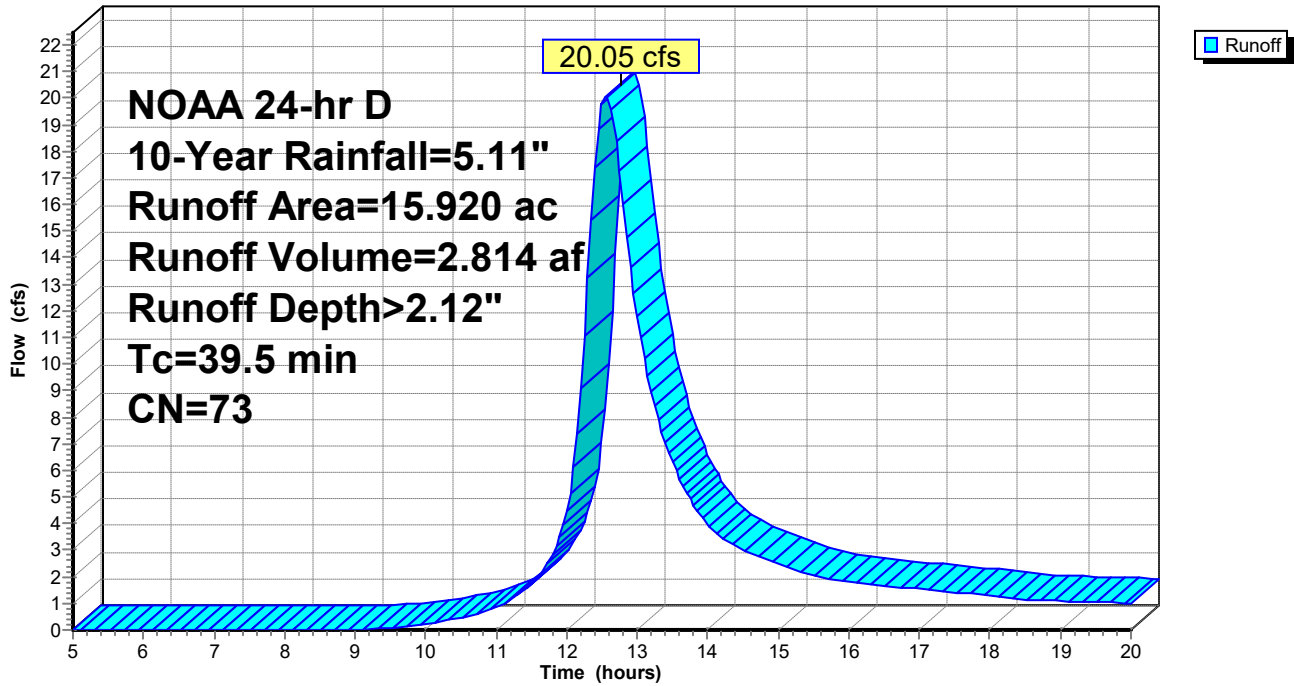

WR-Model06

Prepared by SLR International Corporation

HydroCAD® 10.20-7a s/n 08105 © 2025 HydroCAD Software Solutions LLC

NOAA 24-hr D 10-Year Rainfall=5.11"

Printed 7/24/2025

Page 68

Summary for Subcatchment 10S: PRWS-20

Runoff = 6.79 cfs @ 12.24 hrs, Volume= 0.628 af, Depth> 2.92"
Routed to Link 18L : PR POA / B

Runoff by SCS TR-20 method, UH=SCS, Weighted-CN, Time Span= 5.00-20.00 hrs, dt= 0.05 hrs
NOAA 24-hr D 10-Year Rainfall=5.11"

Area (ac)	CN	Description
* 2.580	82	
2.580		100.00% Pervious Area

Tc (min)	Length (feet)	Slope (ft/ft)	Velocity (ft/sec)	Capacity (cfs)	Description
15.9					Direct Entry,

Subcatchment 10S: PRWS-20

Hydrograph

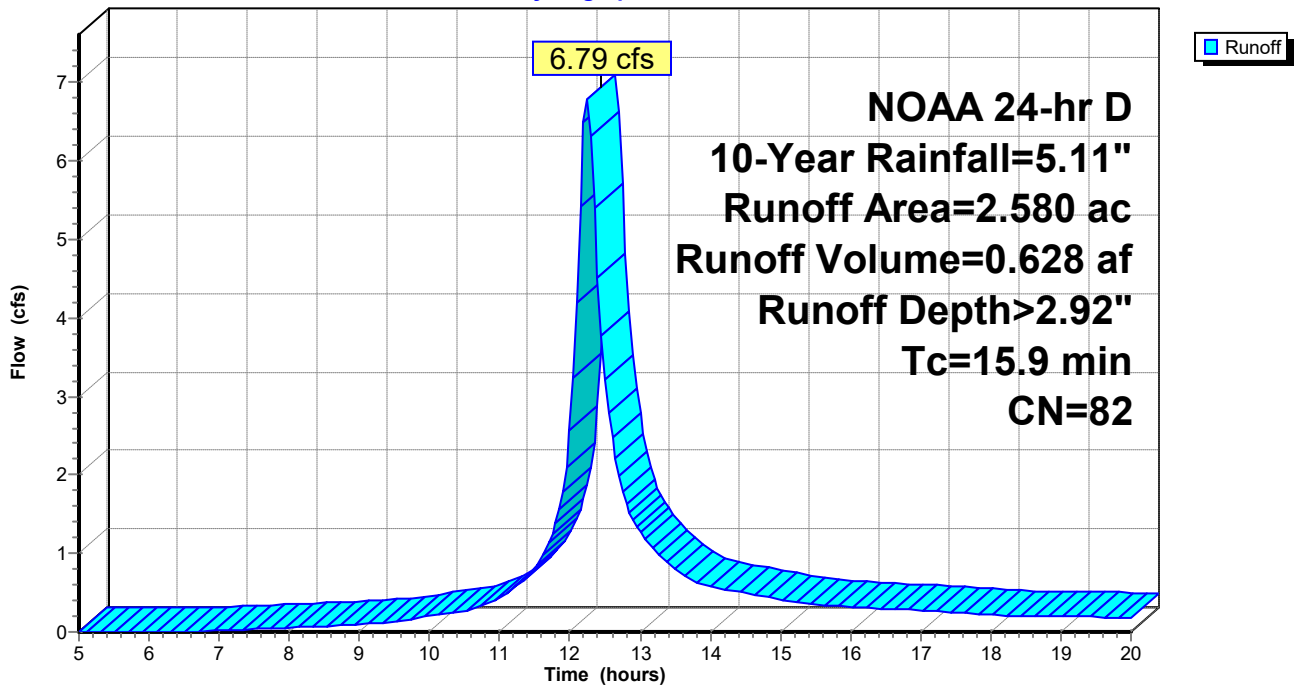

Summary for Subcatchment 11S: PRWS-21

Runoff = 10.70 cfs @ 12.16 hrs, Volume= 0.853 af, Depth> 3.61"
Routed to Pond 16P : DET 210

Runoff by SCS TR-20 method, UH=SCS, Weighted-CN, Time Span= 5.00-20.00 hrs, dt= 0.05 hrs
NOAA 24-hr D 10-Year Rainfall=5.11"

Area (ac)	CN	Description
* 2.840	89	
2.840		100.00% Pervious Area

Tc (min)	Length (feet)	Slope (ft/ft)	Velocity (ft/sec)	Capacity (cfs)	Description
9.4					Direct Entry,

Subcatchment 11S: PRWS-21

Hydrograph

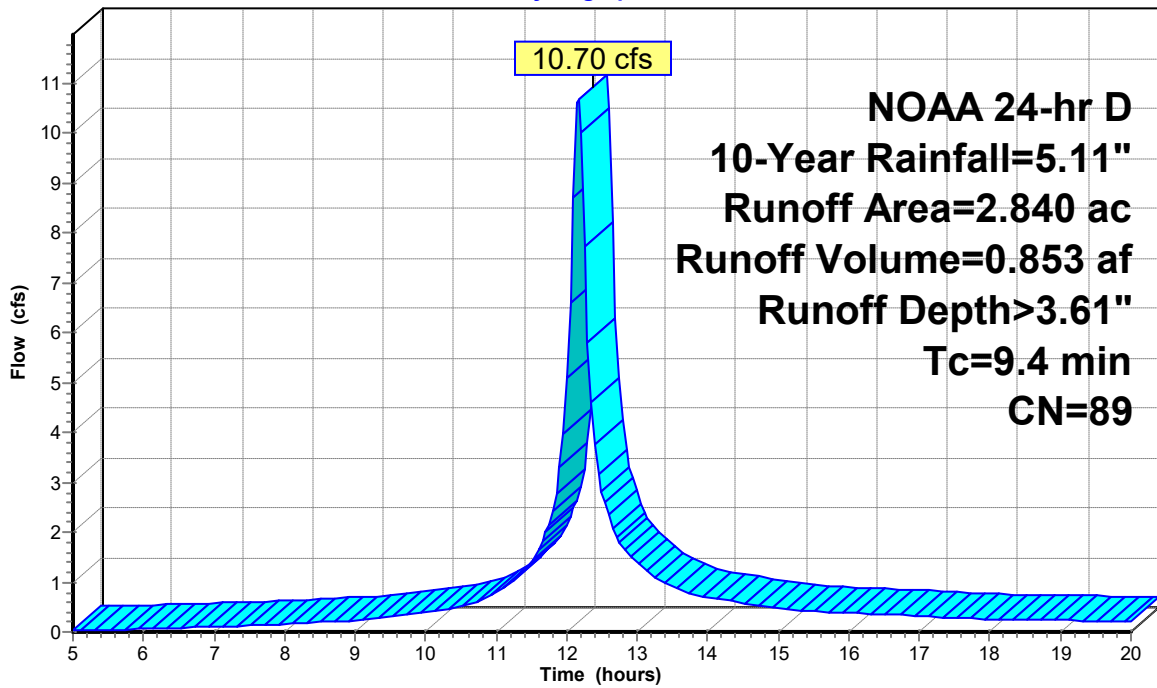

WR-Model06

Prepared by SLR International Corporation
HydroCAD® 10.20-7a s/n 08105 © 2025 HydroCAD Software Solutions LLC

NOAA 24-hr D 10-Year Rainfall=5.11"

Printed 7/24/2025

Page 70

Summary for Subcatchment 12S: PRWS-22

Runoff = 2.89 cfs @ 12.17 hrs, Volume= 0.235 af, Depth> 3.70"
Routed to Pond 17P : DET 220

Runoff by SCS TR-20 method, UH=SCS, Weighted-CN, Time Span= 5.00-20.00 hrs, dt= 0.05 hrs
NOAA 24-hr D 10-Year Rainfall=5.11"

Area (ac)	CN	Description
* 0.760	90	
0.760		100.00% Pervious Area

Tc (min)	Length (feet)	Slope (ft/ft)	Velocity (ft/sec)	Capacity (cfs)	Description
9.7					Direct Entry,

Subcatchment 12S: PRWS-22

Hydrograph

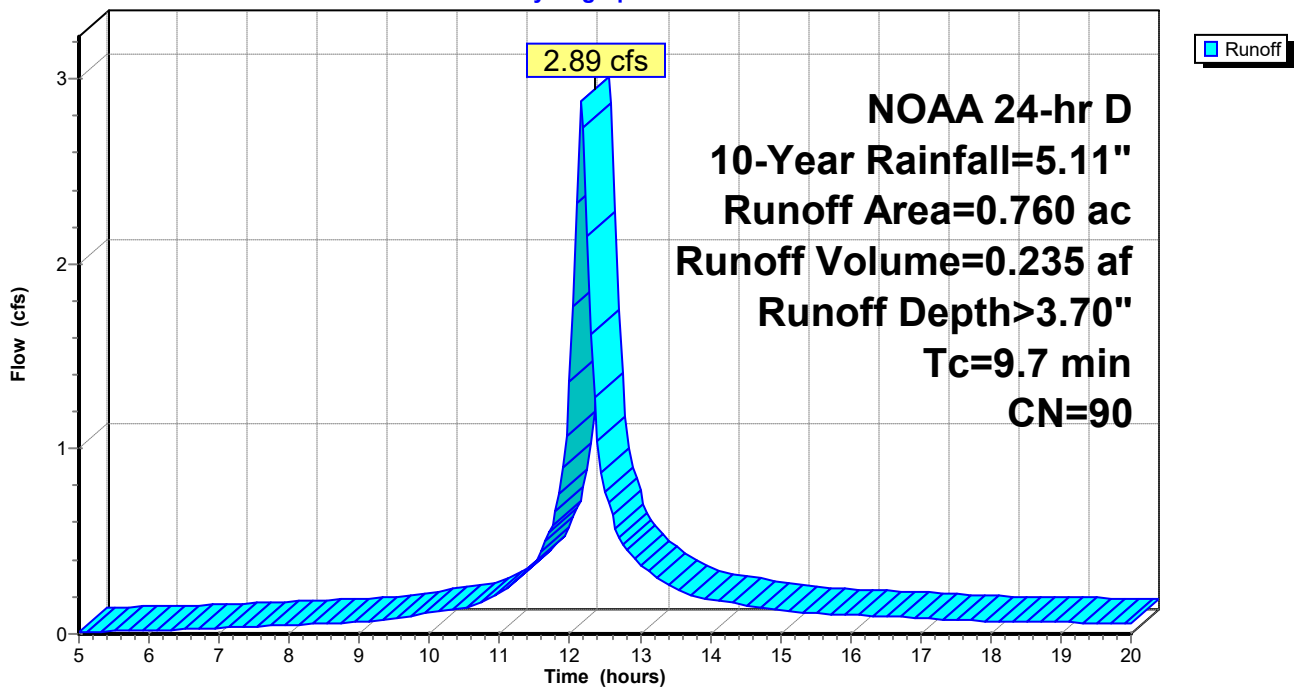

Summary for Subcatchment 13S: PRWS-30 / C

Runoff = 2.84 cfs @ 12.21 hrs, Volume= 0.242 af, Depth> 2.57"

Runoff by SCS TR-20 method, UH=SCS, Weighted-CN, Time Span= 5.00-20.00 hrs, dt= 0.05 hrs
NOAA 24-hr D 10-Year Rainfall=5.11"

Area (ac)	CN	Description
* 1.130	78	
1.130		100.00% Pervious Area

Tc (min)	Length (feet)	Slope (ft/ft)	Velocity (ft/sec)	Capacity (cfs)	Description
13.4					Direct Entry,

Subcatchment 13S: PRWS-30 / C

Hydrograph

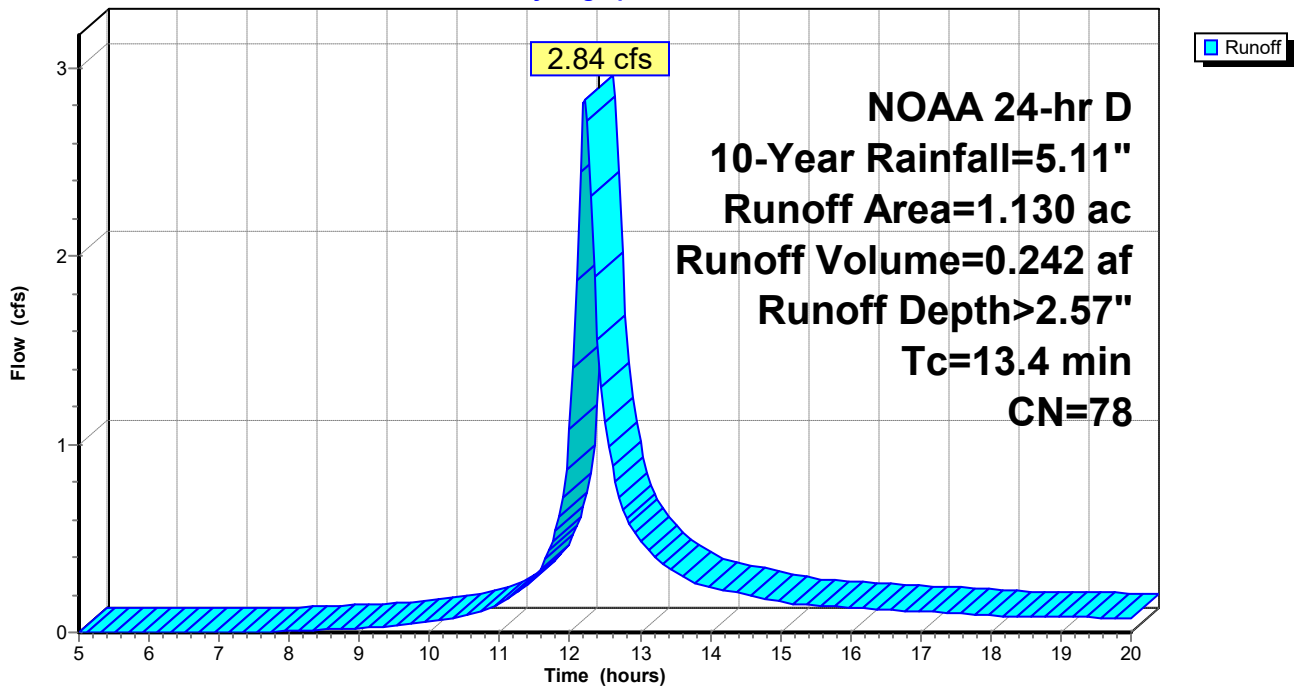

Summary for Subcatchment 20S: PRWS-14

Runoff = 1.22 cfs @ 12.15 hrs, Volume= 0.088 af, Depth> 3.22"
Routed to Pond 23P : WQ 140

Runoff by SCS TR-20 method, UH=SCS, Weighted-CN, Time Span= 5.00-20.00 hrs, dt= 0.05 hrs
NOAA 24-hr D 10-Year Rainfall=5.11"

Area (ac)	CN	Description
* 0.330	85	
0.330		100.00% Pervious Area

Tc (min)	Length (feet)	Slope (ft/ft)	Velocity (ft/sec)	Capacity (cfs)	Description
7.7					Direct Entry,

Subcatchment 20S: PRWS-14

Hydrograph

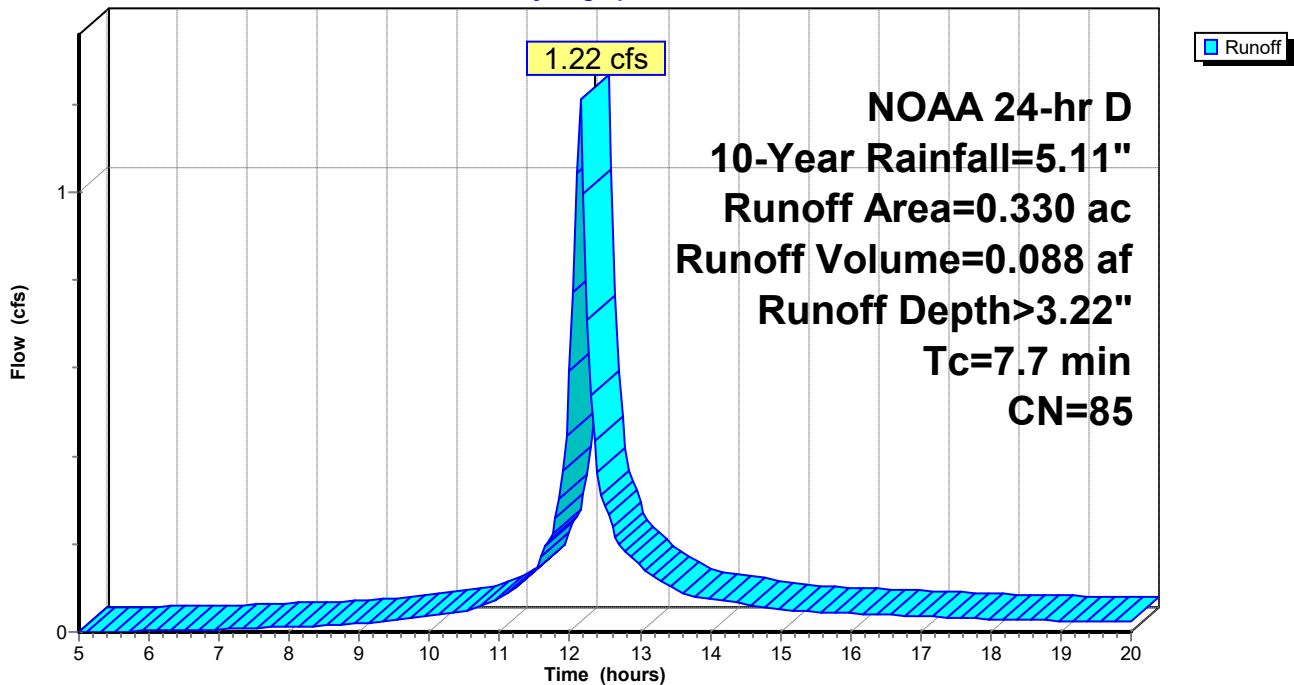

Summary for Pond 16P: DET 210

Inflow Area = 2.840 ac, 0.00% Impervious, Inflow Depth > 3.61" for 10-Year event
 Inflow = 10.70 cfs @ 12.16 hrs, Volume= 0.853 af
 Outflow = 5.57 cfs @ 12.31 hrs, Volume= 0.804 af, Atten= 48%, Lag= 9.1 min
 Discarded = 0.64 cfs @ 12.31 hrs, Volume= 0.540 af
 Primary = 4.93 cfs @ 12.31 hrs, Volume= 0.264 af
 Routed to Link 18L : PR POA / B
 Secondary = 0.00 cfs @ 5.00 hrs, Volume= 0.000 af
 Routed to Link 18L : PR POA / B

Routing by Stor-Ind method, Time Span= 5.00-20.00 hrs, dt= 0.05 hrs
 Peak Elev= 816.24' @ 12.31 hrs Surf.Area= 9,234 sf Storage= 10,474 cf

Plug-Flow detention time= 82.9 min calculated for 0.801 af (94% of inflow)
 Center-of-Mass det. time= 61.1 min (826.6 - 765.5)

Volume	Invert	Avail.Storage	Storage Description		
#1	815.00'	28,886 cf	Custom Stage Data (Conic) Listed below (Recalc)		
Elevation (feet)	Surf.Area (sq-ft)	Inc.Store (cubic-feet)	Cum.Store (cubic-feet)	Wet.Area (sq-ft)	
815.00	7,672	0	0	7,672	
816.00	8,907	8,282	8,282	8,948	
817.00	10,296	9,593	17,875	10,380	
818.00	11,741	11,011	28,886	11,872	

Device	Routing	Invert	Outlet Devices	
#1	Discarded	815.00'	3.000 in/hr Exfiltration over Surface area	
#2	Primary	814.50'	15.0" Round Culvert L= 127.0' CPP, projecting, no headwall, Ke= 0.900 Inlet / Outlet Invert= 814.50' / 806.40' S= 0.0638 '/' Cc= 0.900 n= 0.012, Flow Area= 1.23 sf	
#3	Device 2	815.90'	14.0' long Sharp-Crested Rectangular Weir 2 End Contraction(s)	
#4	Secondary	817.20'	10.0' long + 3.0 '/' SideZ x 8.0' breadth Broad-Crested Rectangular Weir Head (feet) 0.20 0.40 0.60 0.80 1.00 1.20 1.40 1.60 1.80 2.00 2.50 3.00 3.50 4.00 4.50 5.00 5.50 Coef. (English) 2.43 2.54 2.70 2.69 2.68 2.68 2.66 2.64 2.64 2.64 2.65 2.65 2.66 2.66 2.68 2.70 2.74	

Discarded OutFlow Max=0.64 cfs @ 12.31 hrs HW=816.24' (Free Discharge)
 ↑1=Exfiltration (Exfiltration Controls 0.64 cfs)

Primary OutFlow Max=4.92 cfs @ 12.31 hrs HW=816.24' (Free Discharge)
 ↑2=Culvert (Inlet Controls 4.92 cfs @ 4.01 fps)
 ↑3=Sharp-Crested Rectangular Weir (Passes 4.92 cfs of 8.98 cfs potential flow)

Secondary OutFlow Max=0.00 cfs @ 5.00 hrs HW=815.00' (Free Discharge)
 ↑4=Broad-Crested Rectangular Weir (Controls 0.00 cfs)

Pond 16P: DET 210

Hydrograph

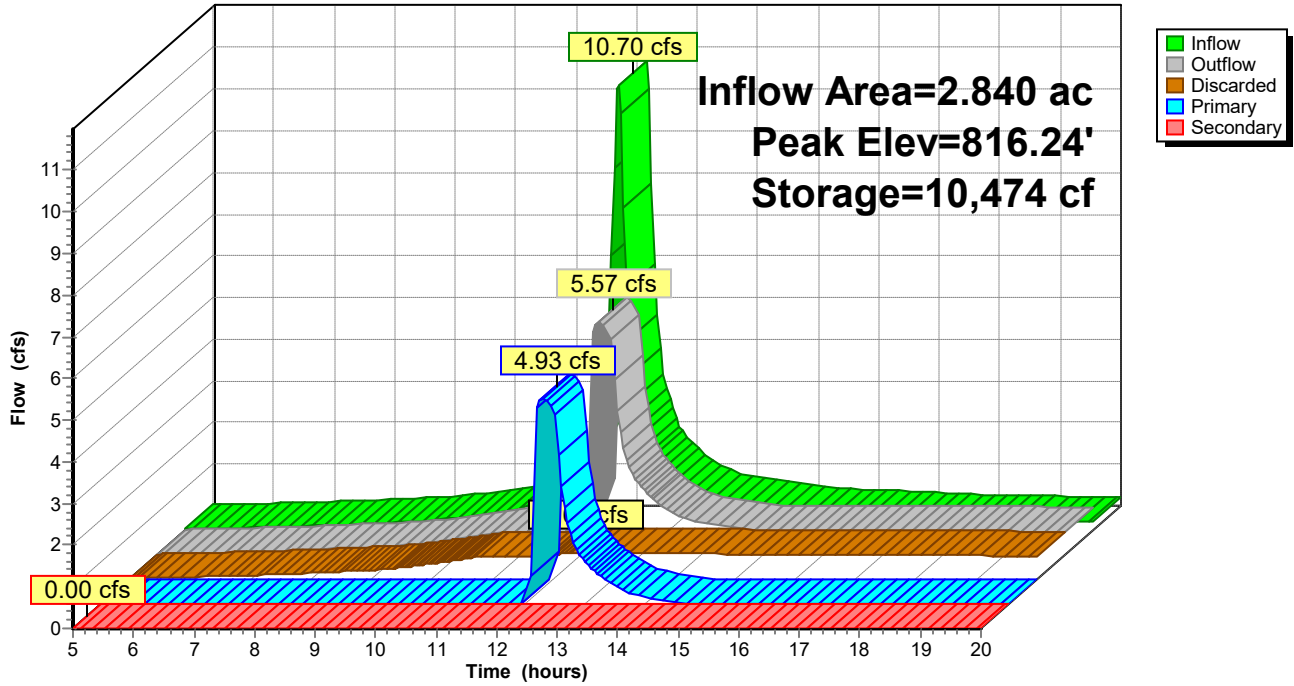

Summary for Pond 17P: DET 220

Inflow Area = 0.760 ac, 0.00% Impervious, Inflow Depth > 3.70" for 10-Year event
 Inflow = 2.89 cfs @ 12.17 hrs, Volume= 0.235 af
 Outflow = 1.75 cfs @ 12.31 hrs, Volume= 0.186 af, Atten= 39%, Lag= 8.5 min
 Discarded = 0.10 cfs @ 12.31 hrs, Volume= 0.081 af
 Primary = 1.65 cfs @ 12.31 hrs, Volume= 0.105 af
 Routed to Link 18L : PR POA / B
 Secondary = 0.00 cfs @ 5.00 hrs, Volume= 0.000 af
 Routed to Link 18L : PR POA / B

Routing by Stor-Ind method, Time Span= 5.00-20.00 hrs, dt= 0.05 hrs
 Peak Elev= 802.88' @ 12.31 hrs Surf.Area= 2,710 sf Storage= 3,808 cf

Plug-Flow detention time= 106.5 min calculated for 0.185 af (79% of inflow)
 Center-of-Mass det. time= 50.5 min (813.2 - 762.8)

Volume	Invert	Avail.Storage	Storage Description		
#1	801.00'	7,722 cf	Custom Stage Data (Conic) Listed below (Recalc)		
Elevation (feet)	Surf.Area (sq-ft)	Inc.Store (cubic-feet)	Cum.Store (cubic-feet)	Wet.Area (sq-ft)	
801.00	1,433	0	0	1,433	
802.00	2,039	1,727	1,727	2,057	
803.00	2,810	2,414	4,141	2,847	
804.00	4,412	3,581	7,722	4,463	

Device	Routing	Invert	Outlet Devices	
#1	Discarded	801.00'	1.580 in/hr Exfiltration over Surface area	
#2	Primary	800.50'	15.0" Round Culvert L= 39.0' CPP, projecting, no headwall, Ke= 0.900 Inlet / Outlet Invert= 800.50' / 800.00' S= 0.0128 '/' Cc= 0.900 n= 0.012, Flow Area= 1.23 sf	
#3	Device 2	802.20'	6.0" Vert. Orifice/Grate C= 0.600 Limited to weir flow at low heads	
#4	Device 2	802.80'	14.0' long Sharp-Crested Rectangular Weir 2 End Contraction(s)	
#5	Secondary	803.00'	10.0' long + 3.0 ' SideZ x 8.0' breadth Broad-Crested Rectangular Weir Head (feet) 0.20 0.40 0.60 0.80 1.00 1.20 1.40 1.60 1.80 2.00 2.50 3.00 3.50 4.00 4.50 5.00 5.50 Coef. (English) 2.43 2.54 2.70 2.69 2.68 2.68 2.66 2.64 2.64 2.64 2.65 2.65 2.66 2.66 2.68 2.70 2.74	

Discarded OutFlow Max=0.10 cfs @ 12.31 hrs HW=802.88' (Free Discharge)
 ↑1=Exfiltration (Exfiltration Controls 0.10 cfs)

Primary OutFlow Max=1.59 cfs @ 12.31 hrs HW=802.88' (Free Discharge)
 ↑2=Culvert (Passes 1.59 cfs of 6.17 cfs potential flow)
 ↑3=Orifice/Grate (Orifice Controls 0.62 cfs @ 3.15 fps)
 ↑4=Sharp-Crested Rectangular Weir (Weir Controls 0.97 cfs @ 0.91 fps)

Secondary OutFlow Max=0.00 cfs @ 5.00 hrs HW=801.00' (Free Discharge)
 ↑5=Broad-Crested Rectangular Weir (Controls 0.00 cfs)

Pond 17P: DET 220

Hydrograph

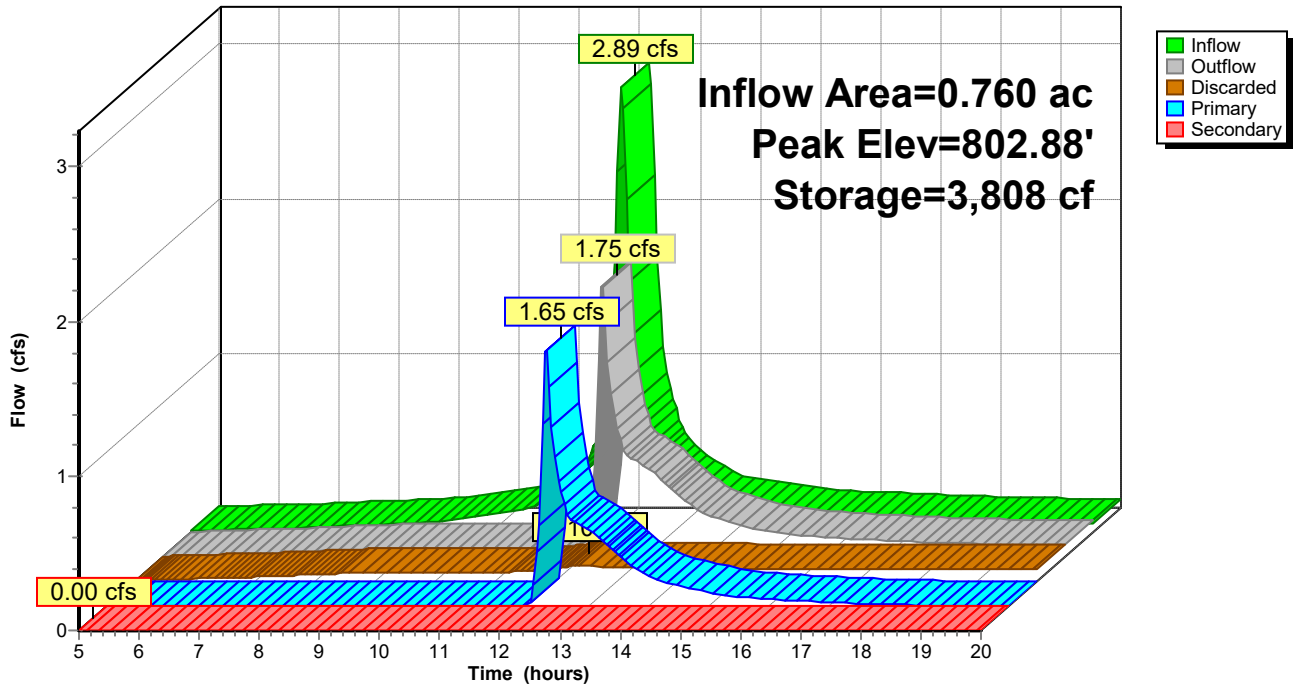

Summary for Pond 23P: WQ 140

Inflow Area = 0.330 ac, 0.00% Impervious, Inflow Depth > 3.22" for 10-Year event
 Inflow = 1.22 cfs @ 12.15 hrs, Volume= 0.088 af
 Outflow = 1.15 cfs @ 12.17 hrs, Volume= 0.066 af, Atten= 5%, Lag= 1.4 min
 Primary = 1.15 cfs @ 12.17 hrs, Volume= 0.066 af
 Routed to Link 15L : PR POA / A

Routing by Stor-Ind method, Time Span= 5.00-20.00 hrs, dt= 0.05 hrs
 Peak Elev= 838.63' @ 12.17 hrs Surf.Area= 1,158 sf Storage= 1,116 cf

Plug-Flow detention time= 107.6 min calculated for 0.066 af (74% of inflow)
 Center-of-Mass det. time= 45.5 min (821.4 - 775.9)

Volume	Invert	Avail.Storage	Storage Description
#1	837.50'	1,554 cf	Custom Stage Data (Prismatic) Listed below (Recalc)
Elevation (feet)	Surf.Area (sq-ft)	Inc.Store (cubic-feet)	Cum.Store (cubic-feet)
837.50	801	0	0
838.00	964	441	441
838.50	1,143	527	968
839.00	1,200	586	1,554

Device	Routing	Invert	Outlet Devices
#1	Primary	838.50'	10.0' long + 3.0 ' SideZ x 8.0' breadth Broad-Crested Rectangular Weir Head (feet) 0.20 0.40 0.60 0.80 1.00 1.20 1.40 1.60 1.80 2.00 2.50 3.00 3.50 4.00 4.50 5.00 5.50 Coef. (English) 2.43 2.54 2.70 2.69 2.68 2.68 2.66 2.64 2.64 2.64 2.65 2.65 2.66 2.66 2.68 2.70 2.74

Primary OutFlow Max=1.12 cfs @ 12.17 hrs HW=838.63' (Free Discharge)
 ↑1=**Broad-Crested Rectangular Weir** (Weir Controls 1.12 cfs @ 0.86 fps)

Pond 23P: WQ 140

Hydrograph

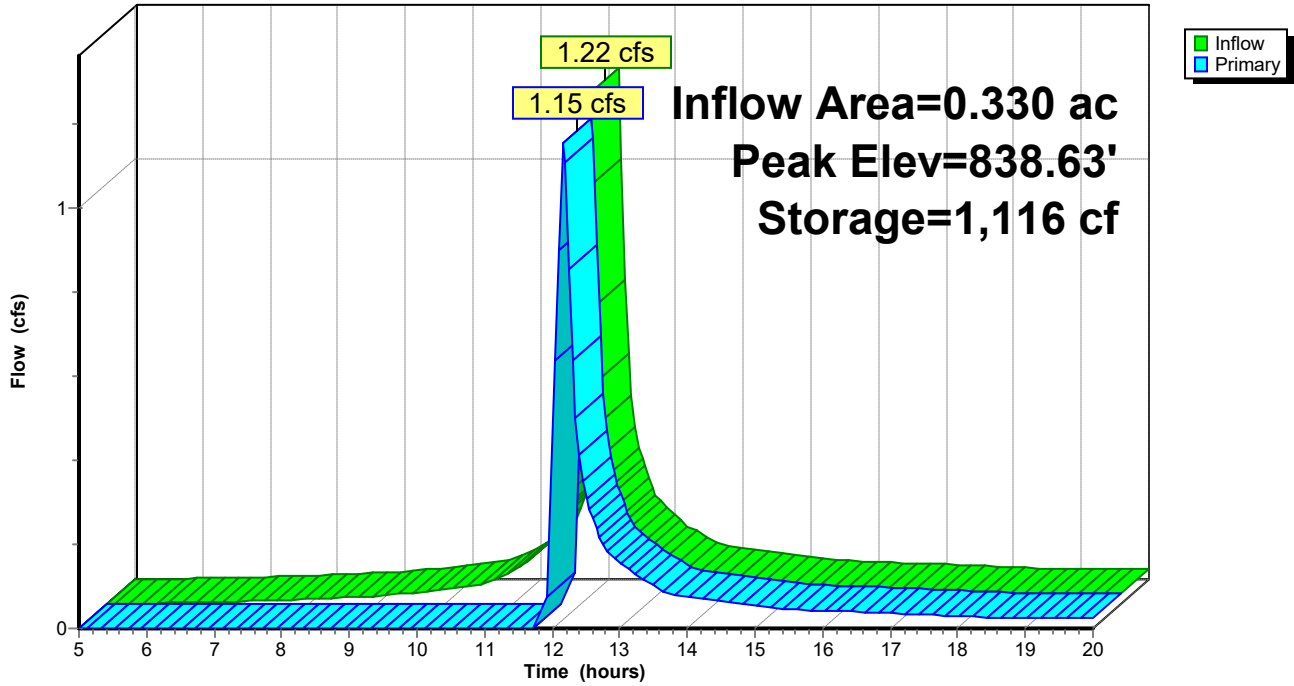

Summary for Link 4L: EX POA / A

Inflow Area = 18.510 ac, 0.00% Impervious, Inflow Depth > 2.16" for 10-Year event
Inflow = 22.32 cfs @ 12.54 hrs, Volume= 3.327 af
Primary = 22.32 cfs @ 12.54 hrs, Volume= 3.327 af, Atten= 0%, Lag= 0.0 min

Primary outflow = Inflow, Time Span= 5.00-20.00 hrs, dt= 0.05 hrs

Link 4L: EX POA / A

Hydrograph

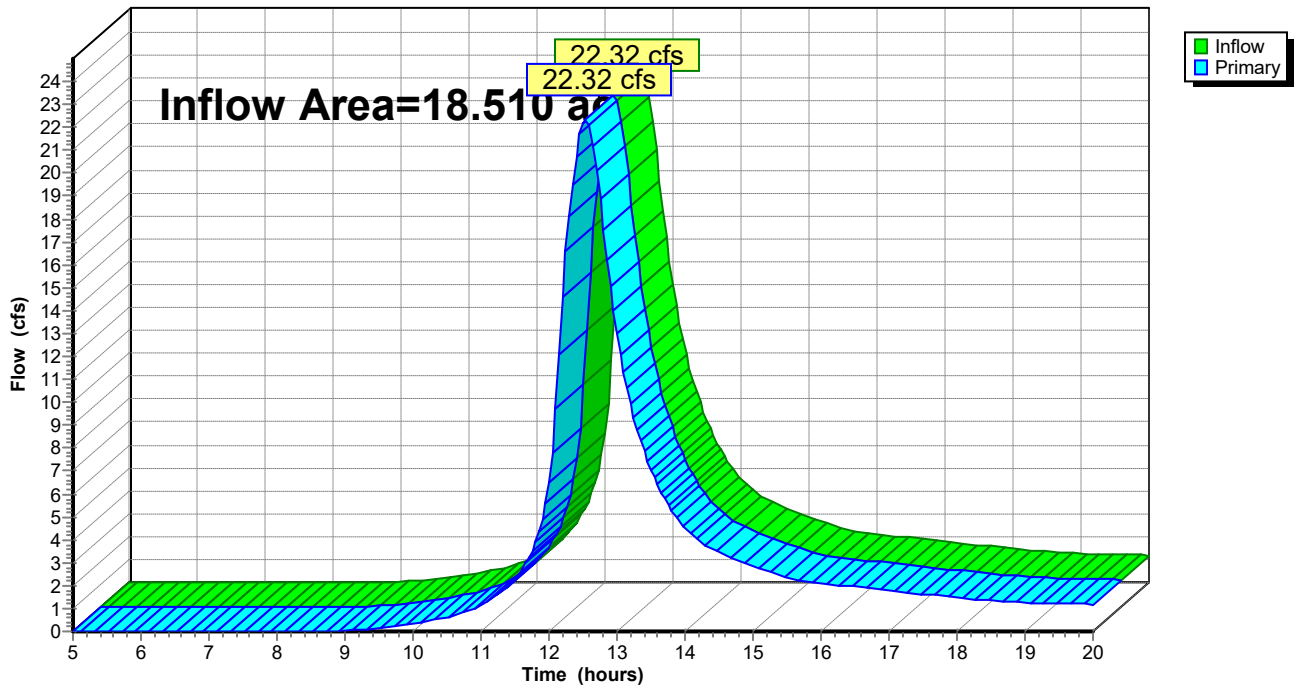

Summary for Link 15L: PR POA / A

Inflow Area = 17.850 ac, 0.00% Impervious, Inflow Depth > 2.17" for 10-Year event
Inflow = 21.48 cfs @ 12.54 hrs, Volume= 3.222 af
Primary = 21.48 cfs @ 12.54 hrs, Volume= 3.222 af, Atten= 0%, Lag= 0.0 min

Primary outflow = Inflow, Time Span= 5.00-20.00 hrs, dt= 0.05 hrs

Link 15L: PR POA / A

Hydrograph

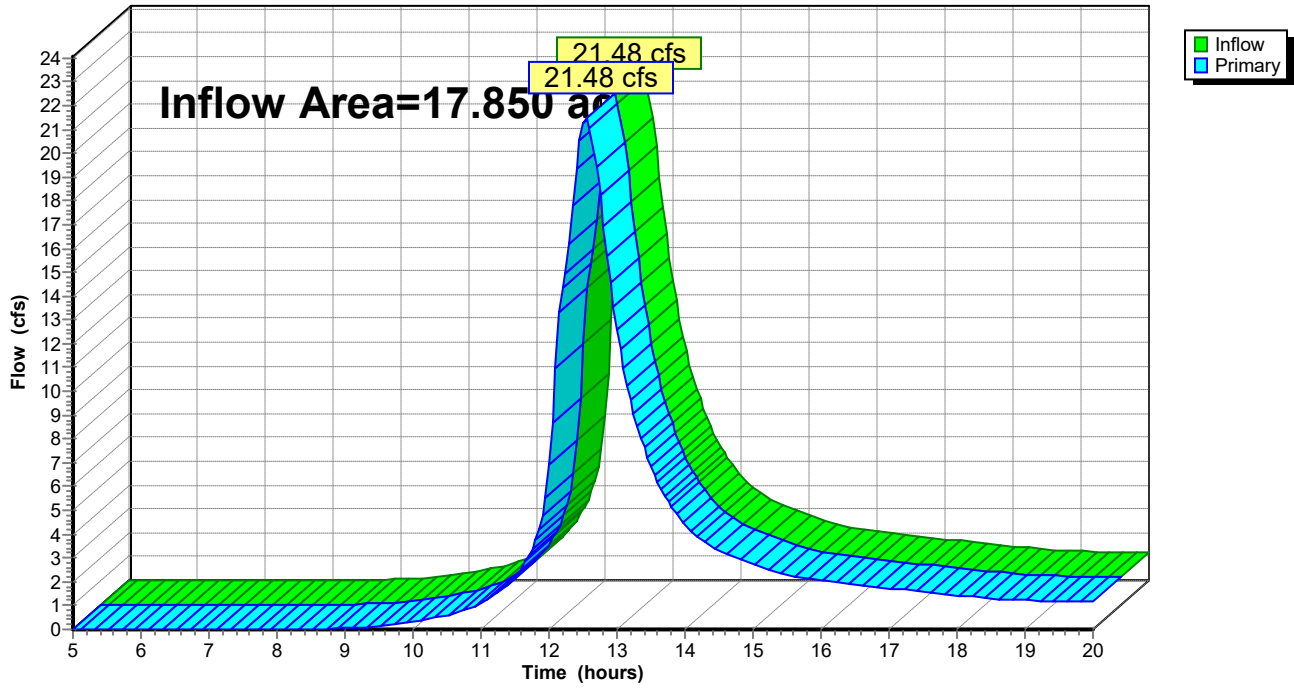

Summary for Link 18L: PR POA / B

Inflow Area = 6.180 ac, 0.00% Impervious, Inflow Depth > 1.94" for 10-Year event
Inflow = 13.01 cfs @ 12.28 hrs, Volume= 0.997 af
Primary = 13.01 cfs @ 12.28 hrs, Volume= 0.997 af, Atten= 0%, Lag= 0.0 min

Primary outflow = Inflow, Time Span= 5.00-20.00 hrs, dt= 0.05 hrs

Link 18L: PR POA / B

Hydrograph

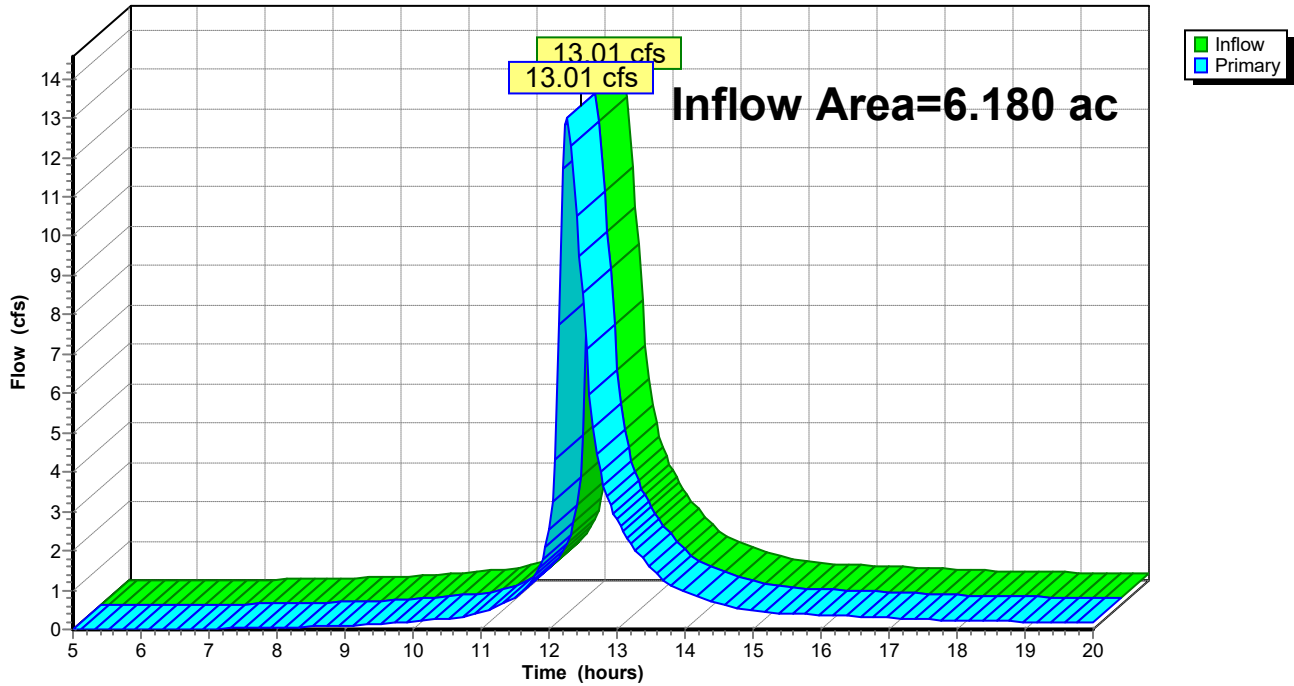

Summary for Subcatchment 1S: EXWS-10

Runoff = 7.94 cfs @ 12.22 hrs, Volume= 0.696 af, Depth> 3.39"
 Routed to Link 4L : EX POA / A

Runoff by SCS TR-20 method, UH=SCS, Weighted-CN, Time Span= 5.00-20.00 hrs, dt= 0.05 hrs
 NOAA 24-hr D 25-Year Rainfall=6.37"

Area (ac)	CN	Description
* 2.460	76	
2.460		100.00% Pervious Area

Tc (min)	Length (feet)	Slope (ft/ft)	Velocity (ft/sec)	Capacity (cfs)	Description
14.2					Direct Entry,

Subcatchment 1S: EXWS-10

Hydrograph

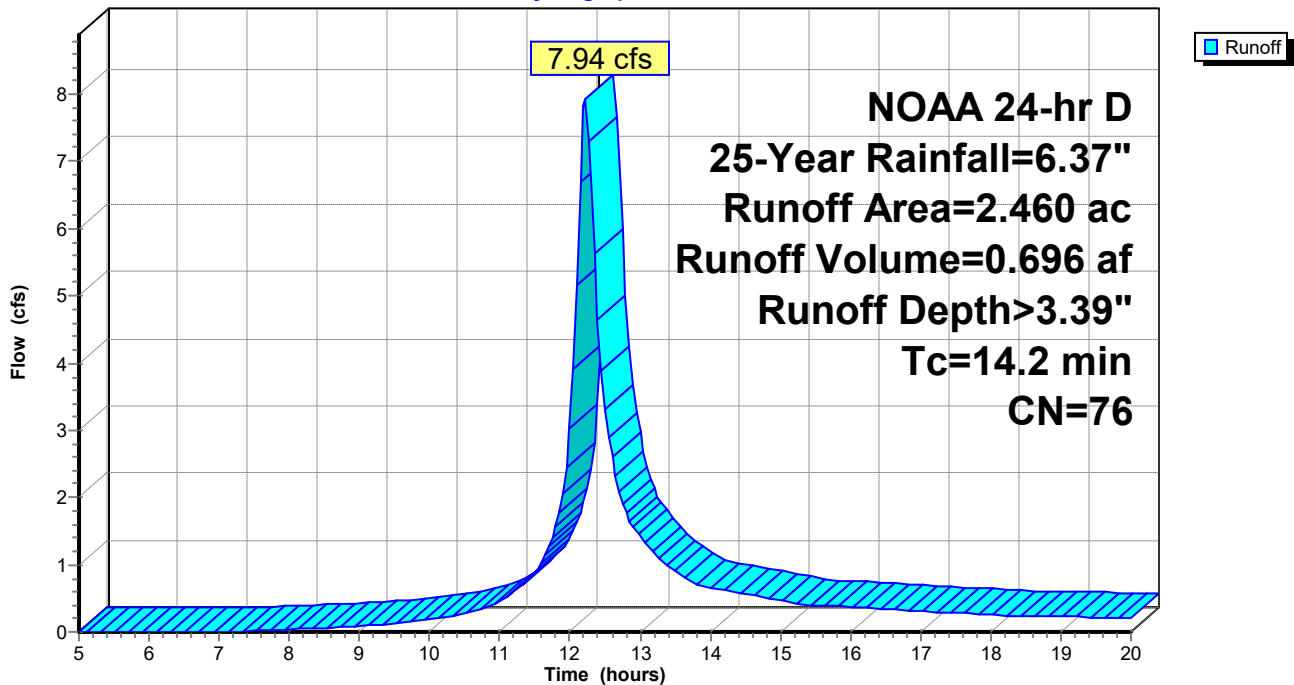

Summary for Subcatchment 2S: EXWS-11

Runoff = 29.23 cfs @ 12.55 hrs, Volume= 4.105 af, Depth> 3.07"
Routed to Link 4L : EX POA / A

Runoff by SCS TR-20 method, UH=SCS, Weighted-CN, Time Span= 5.00-20.00 hrs, dt= 0.05 hrs
NOAA 24-hr D 25-Year Rainfall=6.37"

Area (ac)	CN	Description
* 16.050	73	
16.050		100.00% Pervious Area

Tc (min)	Length (feet)	Slope (ft/ft)	Velocity (ft/sec)	Capacity (cfs)	Description
39.6					Direct Entry,

Subcatchment 2S: EXWS-11

Hydrograph

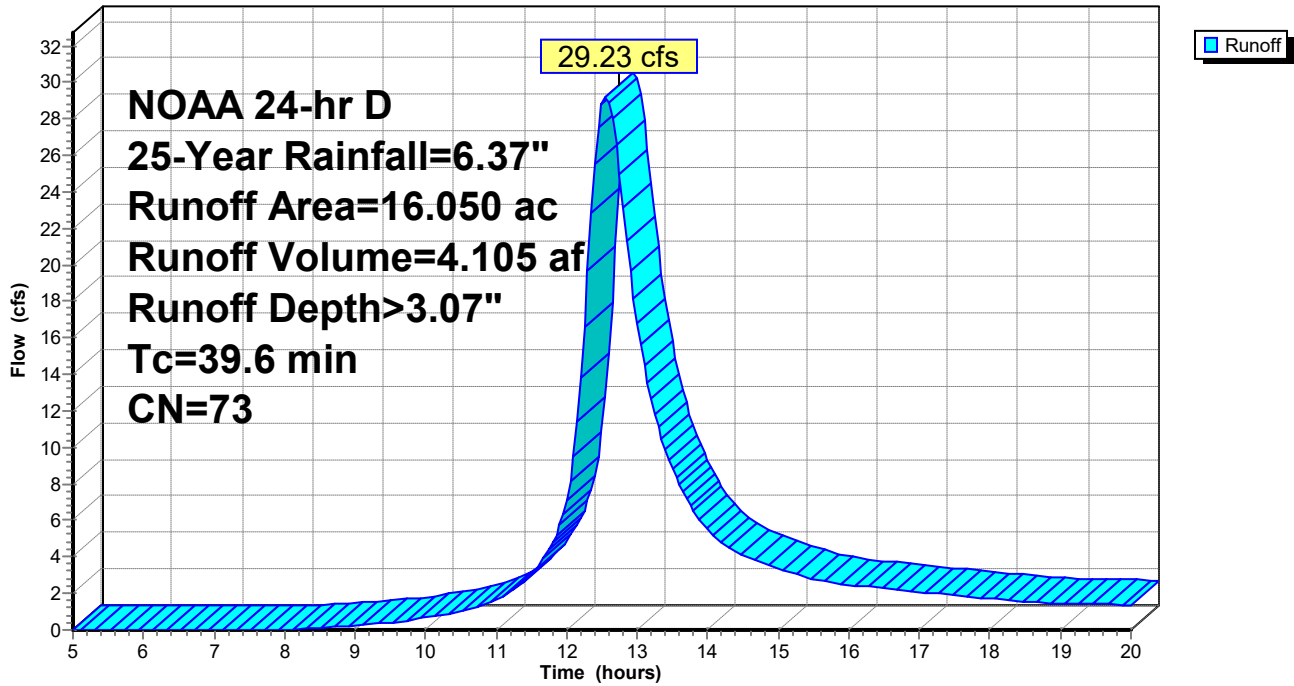

Summary for Subcatchment 5S: EXWS-20 / B

Runoff = 18.21 cfs @ 12.23 hrs, Volume= 1.667 af, Depth> 4.00"

Runoff by SCS TR-20 method, UH=SCS, Weighted-CN, Time Span= 5.00-20.00 hrs, dt= 0.05 hrs
 NOAA 24-hr D 25-Year Rainfall=6.37"

Area (ac)	CN	Description
* 5.000	82	
5.000		100.00% Pervious Area

Tc (min)	Length (feet)	Slope (ft/ft)	Velocity (ft/sec)	Capacity (cfs)	Description
14.9					Direct Entry,

Subcatchment 5S: EXWS-20 / B

Hydrograph

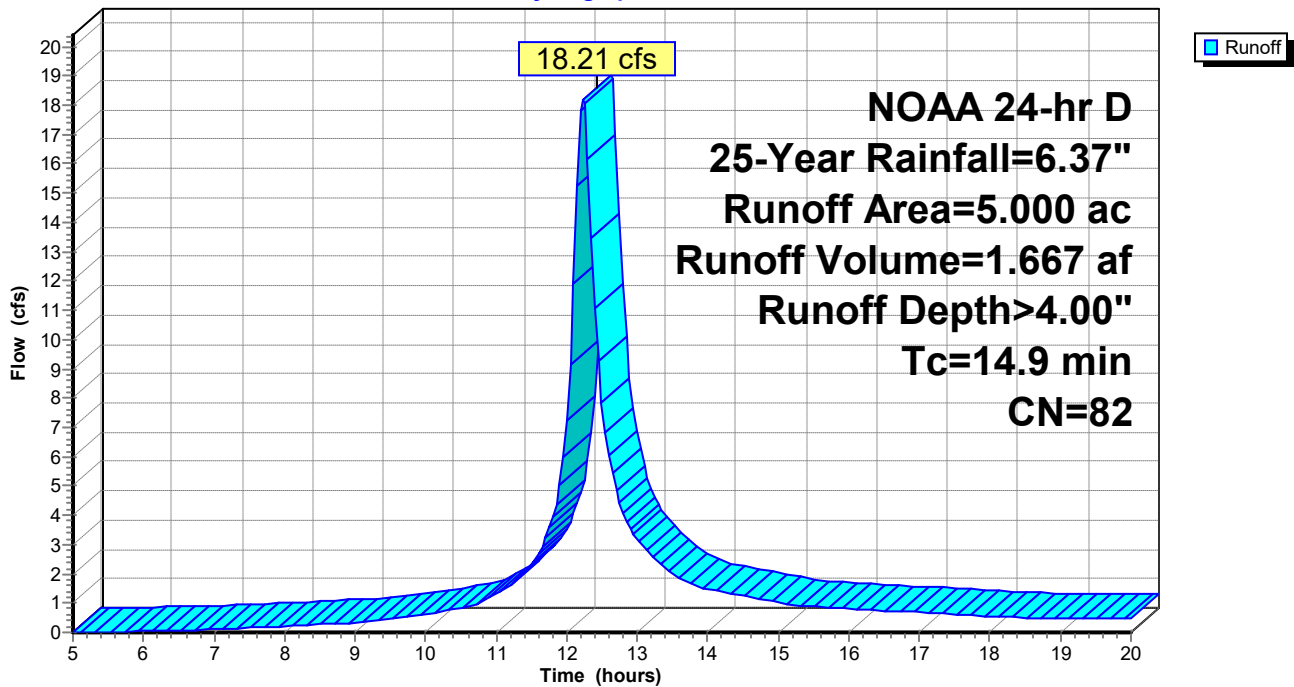

Summary for Subcatchment 6S: EXWS-30 / C

Runoff = 5.58 cfs @ 12.22 hrs, Volume= 0.486 af, Depth> 3.49"

Runoff by SCS TR-20 method, UH=SCS, Weighted-CN, Time Span= 5.00-20.00 hrs, dt= 0.05 hrs
NOAA 24-hr D 25-Year Rainfall=6.37"

Area (ac)	CN	Description
* 1.670	77	
1.670		100.00% Pervious Area

Tc (min)	Length (feet)	Slope (ft/ft)	Velocity (ft/sec)	Capacity (cfs)	Description
14.0					Direct Entry,

Subcatchment 6S: EXWS-30 / C

Hydrograph

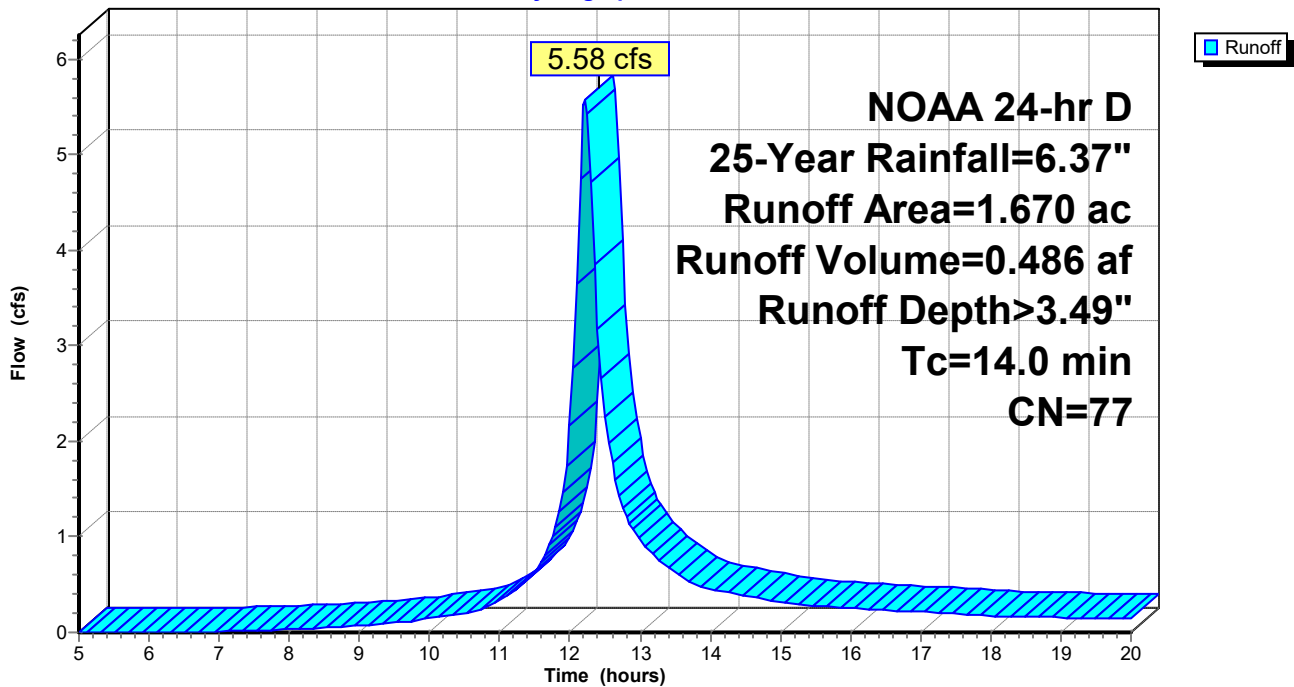

Summary for Subcatchment 7S: PRWS-10

Runoff = 6.61 cfs @ 12.15 hrs, Volume= 0.480 af, Depth> 3.60"
Routed to Link 15L : PR POA / A

Runoff by SCS TR-20 method, UH=SCS, Weighted-CN, Time Span= 5.00-20.00 hrs, dt= 0.05 hrs
NOAA 24-hr D 25-Year Rainfall=6.37"

Area (ac)	CN	Description
* 1.600	78	
1.600		100.00% Pervious Area

Tc (min)	Length (feet)	Slope (ft/ft)	Velocity (ft/sec)	Capacity (cfs)	Description
8.2					Direct Entry,

Subcatchment 7S: PRWS-10

Hydrograph

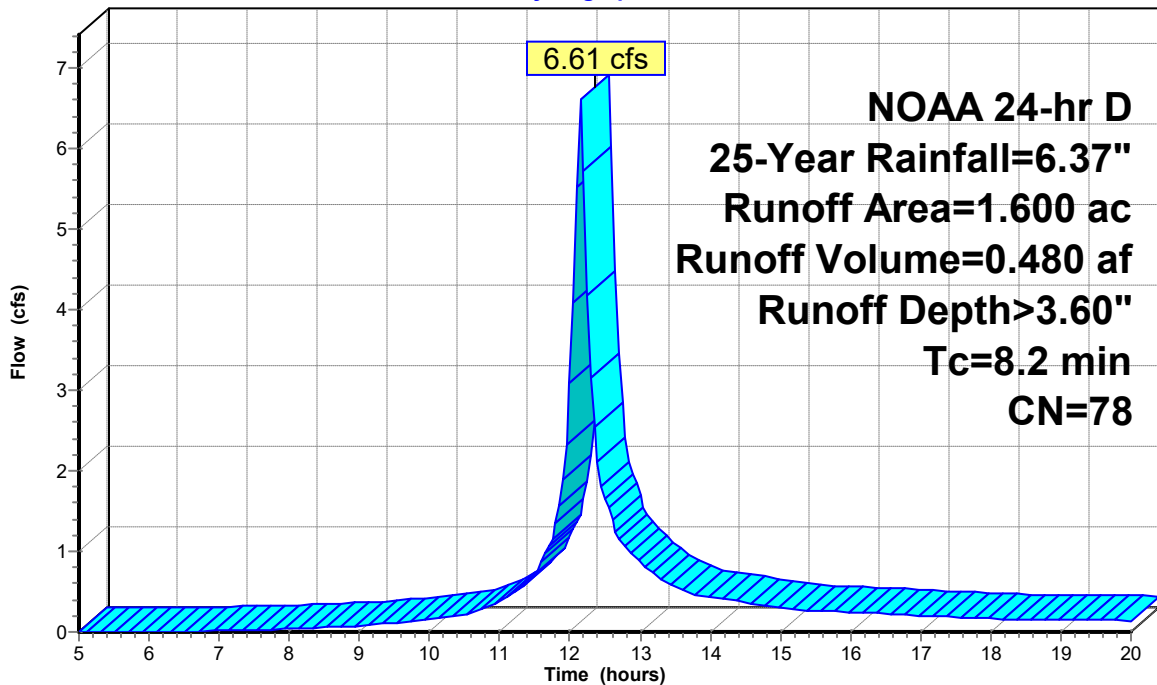

Runoff

**NOAA 24-hr D
25-Year Rainfall=6.37"
Runoff Area=1.600 ac
Runoff Volume=0.480 af
Runoff Depth>3.60"
Tc=8.2 min
CN=78**

Summary for Subcatchment 8S: PRWS-11

Runoff = 29.03 cfs @ 12.55 hrs, Volume= 4.072 af, Depth> 3.07"
Routed to Link 15L : PR POA / A

Runoff by SCS TR-20 method, UH=SCS, Weighted-CN, Time Span= 5.00-20.00 hrs, dt= 0.05 hrs
NOAA 24-hr D 25-Year Rainfall=6.37"

Table with 3 columns: Area (ac), CN, Description. Row 1: 15.920, 73, 100.00% Pervious Area

Table with 7 columns: Tc (min), Length (feet), Slope (ft/ft), Velocity (ft/sec), Capacity (cfs), Description. Row 1: 39.5, Direct Entry,

Subcatchment 8S: PRWS-11

Hydrograph

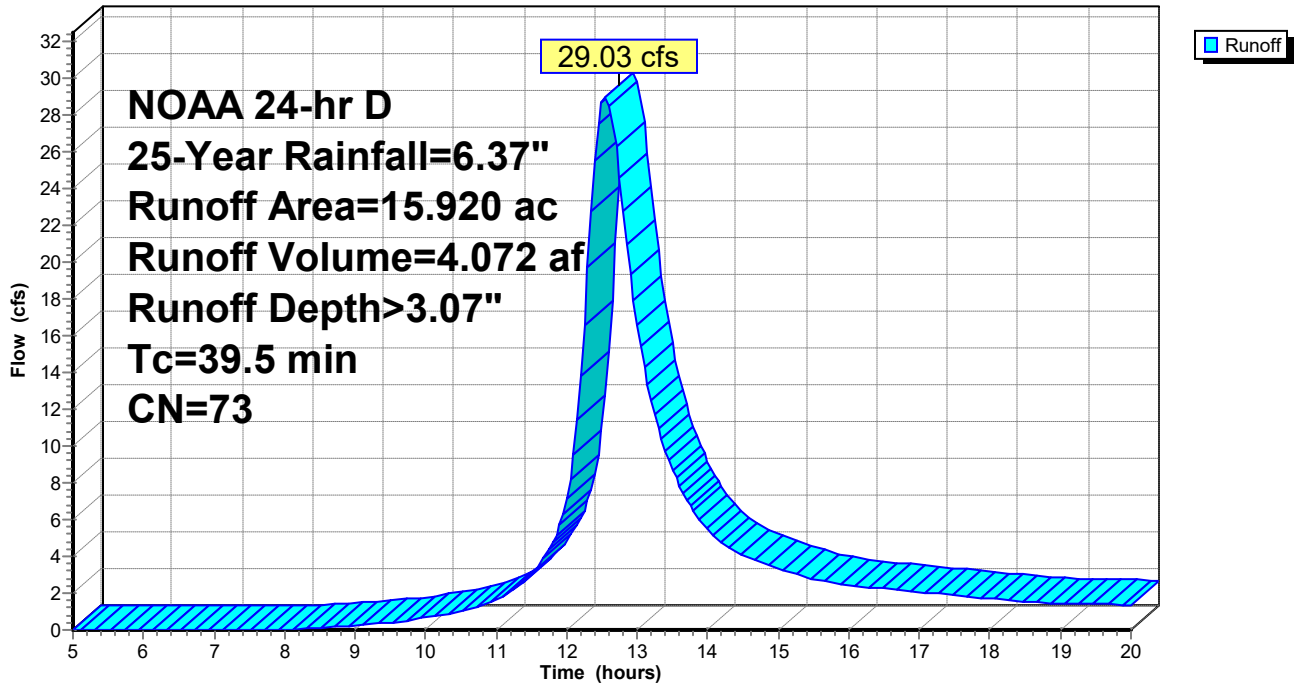

Summary for Subcatchment 10S: PRWS-20

Runoff = 9.17 cfs @ 12.24 hrs, Volume= 0.860 af, Depth> 4.00"
Routed to Link 18L : PR POA / B

Runoff by SCS TR-20 method, UH=SCS, Weighted-CN, Time Span= 5.00-20.00 hrs, dt= 0.05 hrs
NOAA 24-hr D 25-Year Rainfall=6.37"

Area (ac)	CN	Description
* 2.580	82	
2.580		100.00% Pervious Area

Tc (min)	Length (feet)	Slope (ft/ft)	Velocity (ft/sec)	Capacity (cfs)	Description
15.9					Direct Entry,

Subcatchment 10S: PRWS-20

Hydrograph

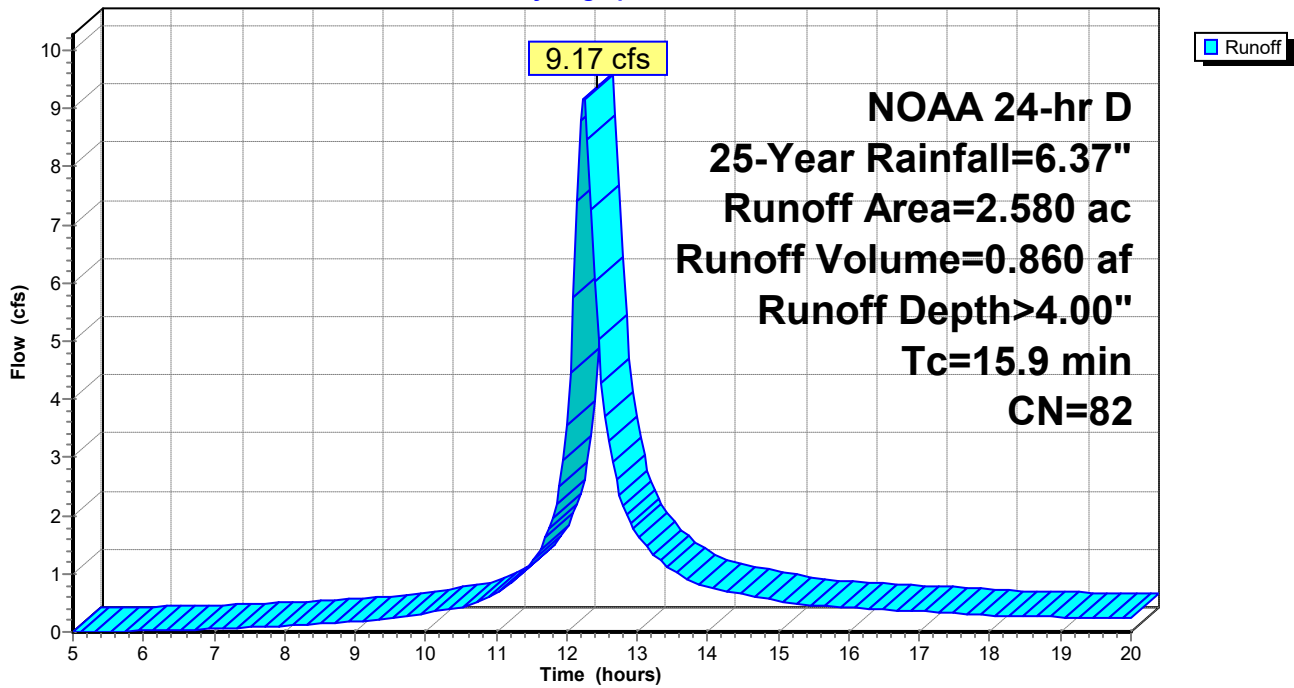

Summary for Subcatchment 11S: PRWS-21

Runoff = 13.84 cfs @ 12.16 hrs, Volume= 1.121 af, Depth> 4.74"
Routed to Pond 16P : DET 210

Runoff by SCS TR-20 method, UH=SCS, Weighted-CN, Time Span= 5.00-20.00 hrs, dt= 0.05 hrs
NOAA 24-hr D 25-Year Rainfall=6.37"

Area (ac)	CN	Description
* 2.840	89	
2.840		100.00% Pervious Area

Tc (min)	Length (feet)	Slope (ft/ft)	Velocity (ft/sec)	Capacity (cfs)	Description
9.4					Direct Entry,

Subcatchment 11S: PRWS-21

Hydrograph

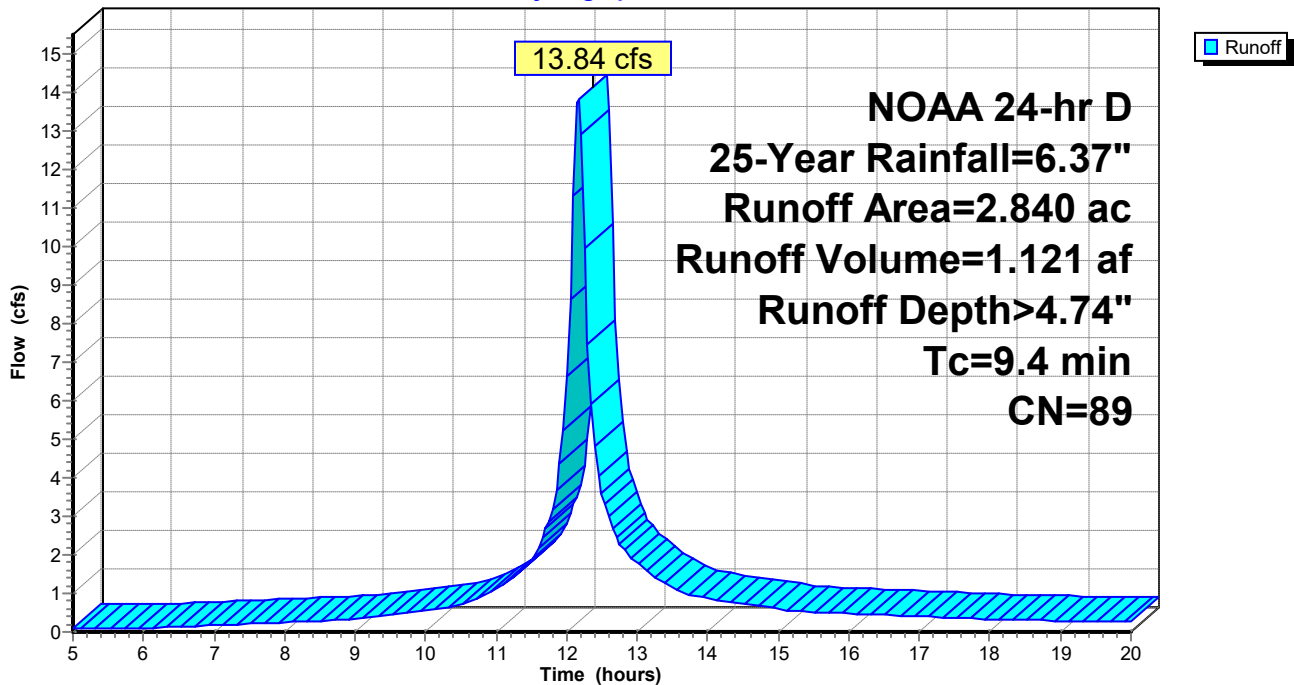

Summary for Subcatchment 12S: PRWS-22

Runoff = 3.71 cfs @ 12.17 hrs, Volume= 0.307 af, Depth> 4.84"
Routed to Pond 17P : DET 220

Runoff by SCS TR-20 method, UH=SCS, Weighted-CN, Time Span= 5.00-20.00 hrs, dt= 0.05 hrs
NOAA 24-hr D 25-Year Rainfall=6.37"

Area (ac)	CN	Description
* 0.760	90	
0.760		100.00% Pervious Area

Tc (min)	Length (feet)	Slope (ft/ft)	Velocity (ft/sec)	Capacity (cfs)	Description
9.7					Direct Entry,

Subcatchment 12S: PRWS-22

Hydrograph

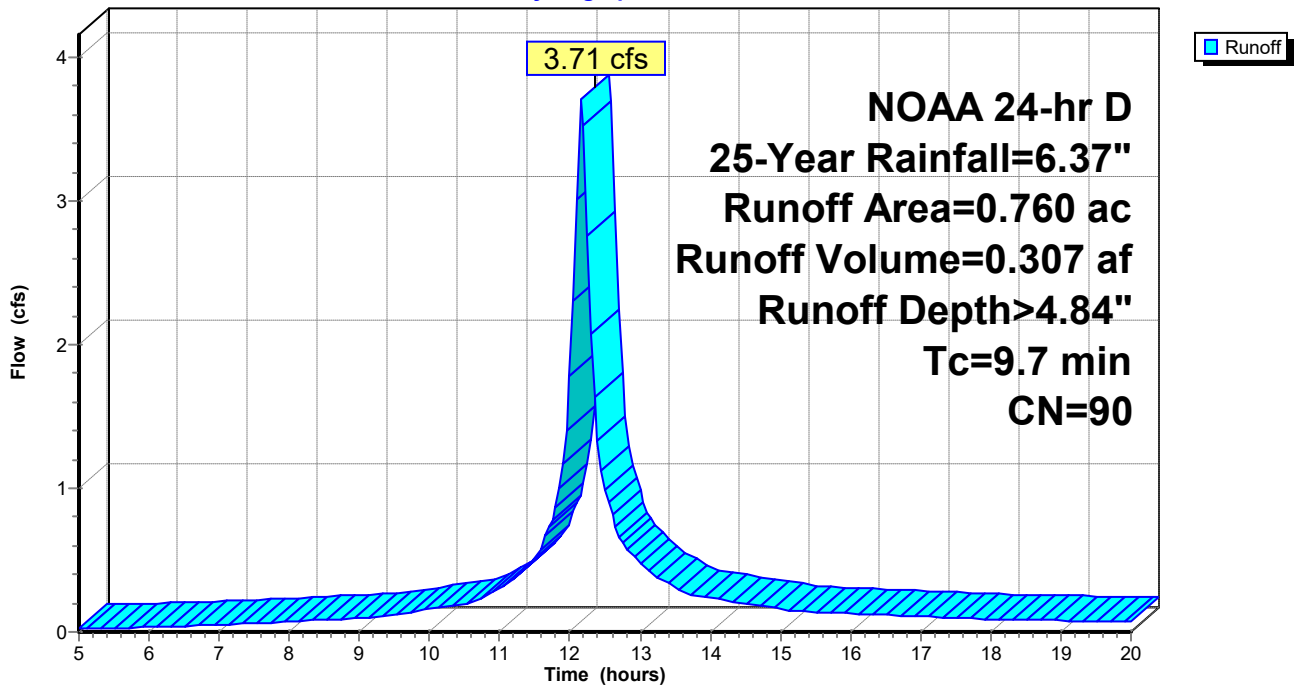

Summary for Subcatchment 13S: PRWS-30 / C

Runoff = 3.94 cfs @ 12.21 hrs, Volume= 0.339 af, Depth> 3.59"

Runoff by SCS TR-20 method, UH=SCS, Weighted-CN, Time Span= 5.00-20.00 hrs, dt= 0.05 hrs
NOAA 24-hr D 25-Year Rainfall=6.37"

Area (ac)	CN	Description
* 1.130	78	
1.130		100.00% Pervious Area

Tc (min)	Length (feet)	Slope (ft/ft)	Velocity (ft/sec)	Capacity (cfs)	Description
13.4					Direct Entry,

Subcatchment 13S: PRWS-30 / C

Hydrograph

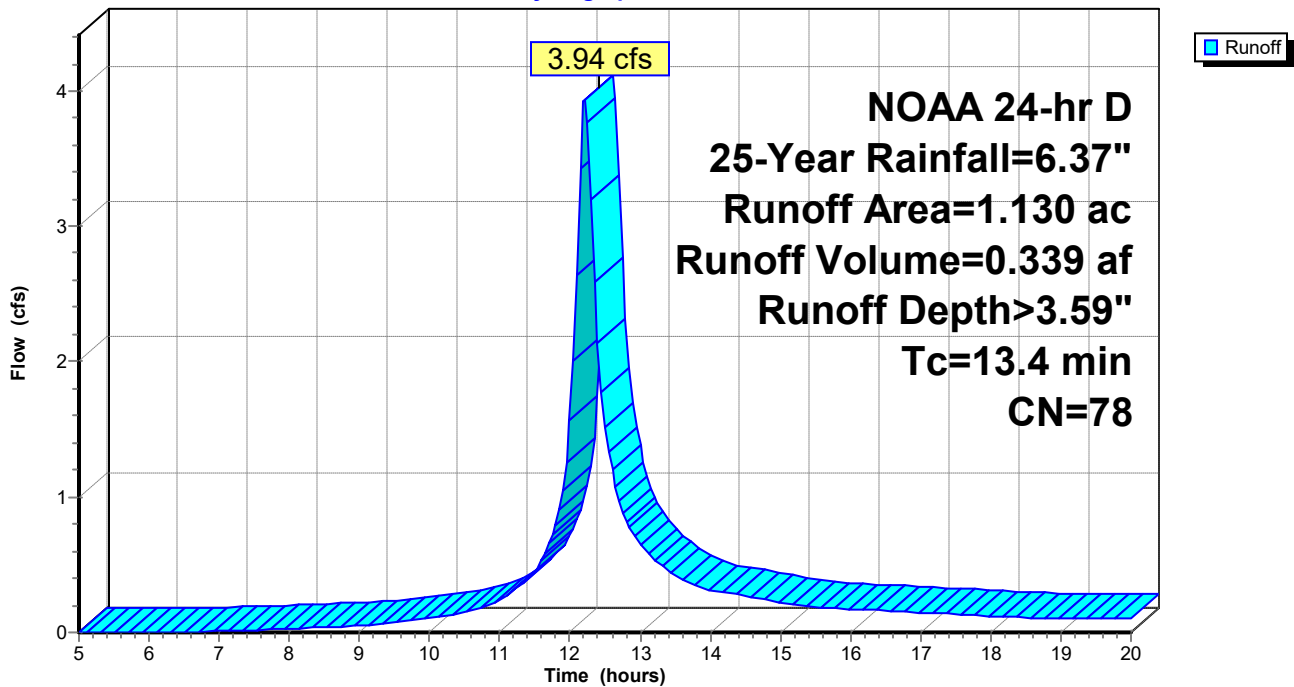

Summary for Subcatchment 20S: PRWS-14

Runoff = 1.61 cfs @ 12.15 hrs, Volume= 0.119 af, Depth> 4.33"
Routed to Pond 23P : WQ 140

Runoff by SCS TR-20 method, UH=SCS, Weighted-CN, Time Span= 5.00-20.00 hrs, dt= 0.05 hrs
NOAA 24-hr D 25-Year Rainfall=6.37"

Area (ac)	CN	Description
* 0.330	85	
0.330		100.00% Pervious Area

Tc (min)	Length (feet)	Slope (ft/ft)	Velocity (ft/sec)	Capacity (cfs)	Description
7.7					Direct Entry,

Subcatchment 20S: PRWS-14

Hydrograph

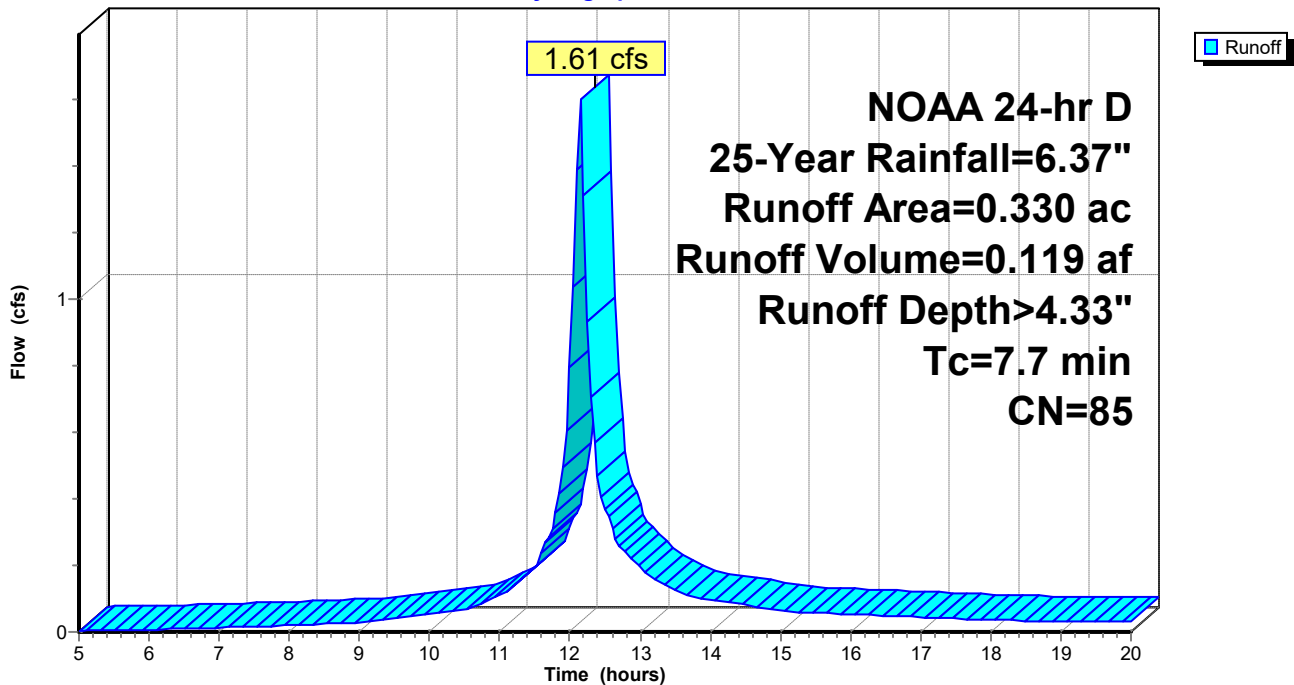

Summary for Pond 16P: DET 210

Inflow Area = 2.840 ac, 0.00% Impervious, Inflow Depth > 4.74" for 25-Year event
 Inflow = 13.84 cfs @ 12.16 hrs, Volume= 1.121 af
 Outflow = 6.31 cfs @ 12.34 hrs, Volume= 1.039 af, Atten= 54%, Lag= 10.7 min
 Discarded = 0.67 cfs @ 12.34 hrs, Volume= 0.584 af
 Primary = 5.63 cfs @ 12.34 hrs, Volume= 0.454 af
 Routed to Link 18L : PR POA / B
 Secondary = 0.00 cfs @ 5.00 hrs, Volume= 0.000 af
 Routed to Link 18L : PR POA / B

Routing by Stor-Ind method, Time Span= 5.00-20.00 hrs, dt= 0.05 hrs
 Peak Elev= 816.58' @ 12.34 hrs Surf.Area= 9,706 sf Storage= 13,713 cf

Plug-Flow detention time= 71.9 min calculated for 1.035 af (92% of inflow)
 Center-of-Mass det. time= 45.0 min (804.6 - 759.6)

Volume	Invert	Avail.Storage	Storage Description		
#1	815.00'	28,886 cf	Custom Stage Data (Conic) Listed below (Recalc)		
Elevation (feet)	Surf.Area (sq-ft)	Inc.Store (cubic-feet)	Cum.Store (cubic-feet)	Wet.Area (sq-ft)	
815.00	7,672	0	0	7,672	
816.00	8,907	8,282	8,282	8,948	
817.00	10,296	9,593	17,875	10,380	
818.00	11,741	11,011	28,886	11,872	

Device	Routing	Invert	Outlet Devices												
#1	Discarded	815.00'	3.000 in/hr Exfiltration over Surface area												
#2	Primary	814.50'	15.0" Round Culvert L= 127.0' CPP, projecting, no headwall, Ke= 0.900 Inlet / Outlet Invert= 814.50' / 806.40' S= 0.0638 '/' Cc= 0.900 n= 0.012, Flow Area= 1.23 sf												
#3	Device 2	815.90'	14.0' long Sharp-Crested Rectangular Weir 2 End Contraction(s)												
#4	Secondary	817.20'	10.0' long + 3.0 '/' SideZ x 8.0' breadth Broad-Crested Rectangular Weir Head (feet) 0.20 0.40 0.60 0.80 1.00 1.20 1.40 1.60 1.80 2.00 2.50 3.00 3.50 4.00 4.50 5.00 5.50 Coef. (English) 2.43 2.54 2.70 2.69 2.68 2.68 2.66 2.64 2.64 2.64 2.65 2.65 2.66 2.66 2.68 2.70 2.74												

Discarded OutFlow Max=0.67 cfs @ 12.34 hrs HW=816.58' (Free Discharge)
 ↑1=Exfiltration (Exfiltration Controls 0.67 cfs)

Primary OutFlow Max=5.63 cfs @ 12.34 hrs HW=816.58' (Free Discharge)
 ↑2=Culvert (Inlet Controls 5.63 cfs @ 4.59 fps)
 ↑3=Sharp-Crested Rectangular Weir (Passes 5.63 cfs of 25.52 cfs potential flow)

Secondary OutFlow Max=0.00 cfs @ 5.00 hrs HW=815.00' (Free Discharge)
 ↑4=Broad-Crested Rectangular Weir (Controls 0.00 cfs)

Pond 16P: DET 210

Hydrograph

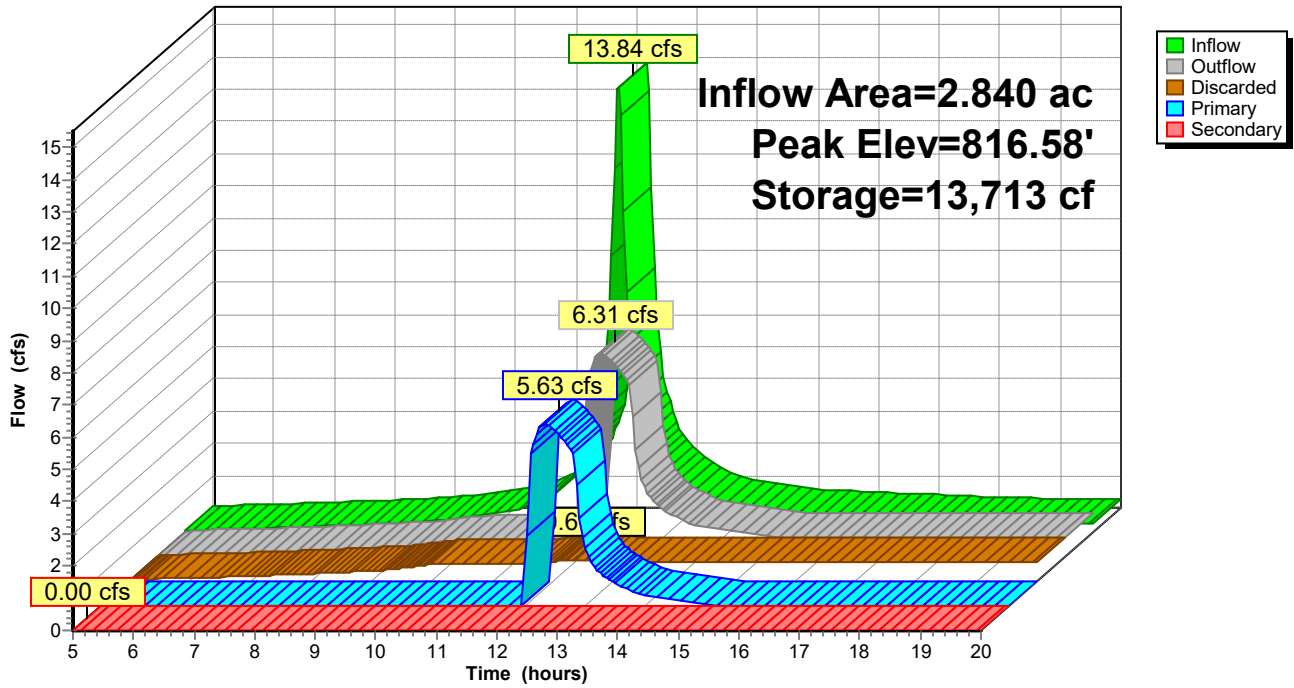

Summary for Pond 17P: DET 220

Inflow Area = 0.760 ac, 0.00% Impervious, Inflow Depth > 4.84" for 25-Year event
 Inflow = 3.71 cfs @ 12.17 hrs, Volume= 0.307 af
 Outflow = 3.55 cfs @ 12.21 hrs, Volume= 0.255 af, Atten= 5%, Lag= 2.8 min
 Discarded = 0.10 cfs @ 12.21 hrs, Volume= 0.087 af
 Primary = 3.44 cfs @ 12.21 hrs, Volume= 0.168 af
 Routed to Link 18L : PR POA / B
 Secondary = 0.00 cfs @ 5.00 hrs, Volume= 0.000 af
 Routed to Link 18L : PR POA / B

Routing by Stor-Ind method, Time Span= 5.00-20.00 hrs, dt= 0.05 hrs
 Peak Elev= 802.95' @ 12.21 hrs Surf.Area= 2,772 sf Storage= 4,014 cf

Plug-Flow detention time= 92.1 min calculated for 0.254 af (83% of inflow)
 Center-of-Mass det. time= 42.8 min (800.0 - 757.3)

Volume	Invert	Avail.Storage	Storage Description		
#1	801.00'	7,722 cf	Custom Stage Data (Conic) Listed below (Recalc)		
Elevation (feet)	Surf.Area (sq-ft)	Inc.Store (cubic-feet)	Cum.Store (cubic-feet)	Wet.Area (sq-ft)	
801.00	1,433	0	0	1,433	
802.00	2,039	1,727	1,727	2,057	
803.00	2,810	2,414	4,141	2,847	
804.00	4,412	3,581	7,722	4,463	

Device	Routing	Invert	Outlet Devices
#1	Discarded	801.00'	1.580 in/hr Exfiltration over Surface area
#2	Primary	800.50'	15.0" Round Culvert L= 39.0' CPP, projecting, no headwall, Ke= 0.900 Inlet / Outlet Invert= 800.50' / 800.00' S= 0.0128 '/' Cc= 0.900 n= 0.012, Flow Area= 1.23 sf
#3	Device 2	802.20'	6.0" Vert. Orifice/Grate C= 0.600 Limited to weir flow at low heads
#4	Device 2	802.80'	14.0' long Sharp-Crested Rectangular Weir 2 End Contraction(s)
#5	Secondary	803.00'	10.0' long + 3.0 ' SideZ x 8.0' breadth Broad-Crested Rectangular Weir Head (feet) 0.20 0.40 0.60 0.80 1.00 1.20 1.40 1.60 1.80 2.00 2.50 3.00 3.50 4.00 4.50 5.00 5.50 Coef. (English) 2.43 2.54 2.70 2.69 2.68 2.68 2.66 2.64 2.64 2.64 2.65 2.65 2.66 2.66 2.68 2.70 2.74

Discarded OutFlow Max=0.10 cfs @ 12.21 hrs HW=802.95' (Free Discharge)
 ↑1=Exfiltration (Exfiltration Controls 0.10 cfs)

Primary OutFlow Max=3.32 cfs @ 12.21 hrs HW=802.95' (Free Discharge)
 ↑2=Culvert (Passes 3.32 cfs of 6.30 cfs potential flow)
 ↑3=Orifice/Grate (Orifice Controls 0.67 cfs @ 3.40 fps)
 ↑4=Sharp-Crested Rectangular Weir (Weir Controls 2.65 cfs @ 1.27 fps)

Secondary OutFlow Max=0.00 cfs @ 5.00 hrs HW=801.00' (Free Discharge)
 ↑5=Broad-Crested Rectangular Weir (Controls 0.00 cfs)

Pond 17P: DET 220

Hydrograph

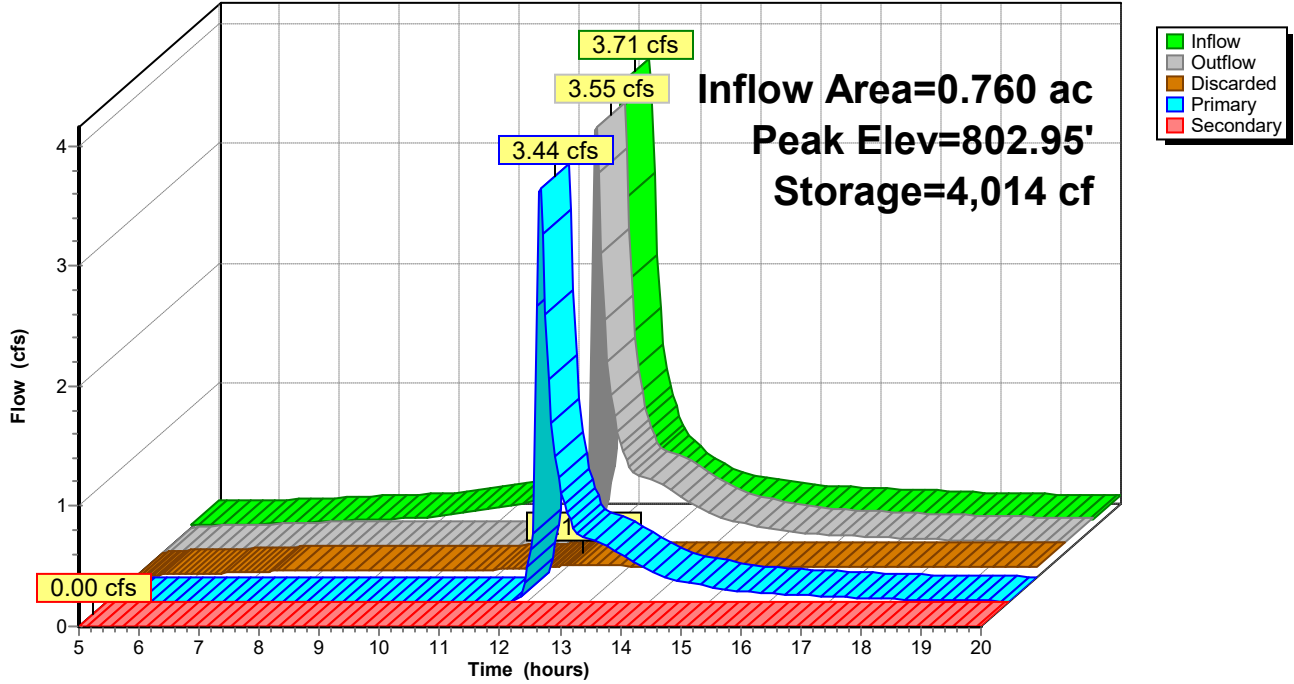

Summary for Pond 23P: WQ 140

Inflow Area = 0.330 ac, 0.00% Impervious, Inflow Depth > 4.33" for 25-Year event
 Inflow = 1.61 cfs @ 12.15 hrs, Volume= 0.119 af
 Outflow = 1.53 cfs @ 12.17 hrs, Volume= 0.096 af, Atten= 4%, Lag= 1.2 min
 Primary = 1.53 cfs @ 12.17 hrs, Volume= 0.096 af
 Routed to Link 15L : PR POA / A

Routing by Stor-Ind method, Time Span= 5.00-20.00 hrs, dt= 0.05 hrs
 Peak Elev= 838.65' @ 12.17 hrs Surf.Area= 1,161 sf Storage= 1,146 cf

Plug-Flow detention time= 93.6 min calculated for 0.096 af (81% of inflow)
 Center-of-Mass det. time= 39.8 min (808.1 - 768.4)

Volume	Invert	Avail.Storage	Storage Description
#1	837.50'	1,554 cf	Custom Stage Data (Prismatic) Listed below (Recalc)
Elevation (feet)	Surf.Area (sq-ft)	Inc.Store (cubic-feet)	Cum.Store (cubic-feet)
837.50	801	0	0
838.00	964	441	441
838.50	1,143	527	968
839.00	1,200	586	1,554

Device	Routing	Invert	Outlet Devices
#1	Primary	838.50'	10.0' long + 3.0 ' SideZ x 8.0' breadth Broad-Crested Rectangular Weir Head (feet) 0.20 0.40 0.60 0.80 1.00 1.20 1.40 1.60 1.80 2.00 2.50 3.00 3.50 4.00 4.50 5.00 5.50 Coef. (English) 2.43 2.54 2.70 2.69 2.68 2.68 2.66 2.64 2.64 2.64 2.65 2.65 2.66 2.66 2.68 2.70 2.74

Primary OutFlow Max=1.49 cfs @ 12.17 hrs HW=838.65' (Free Discharge)
 ↑1=**Broad-Crested Rectangular Weir** (Weir Controls 1.49 cfs @ 0.94 fps)

Pond 23P: WQ 140

Hydrograph

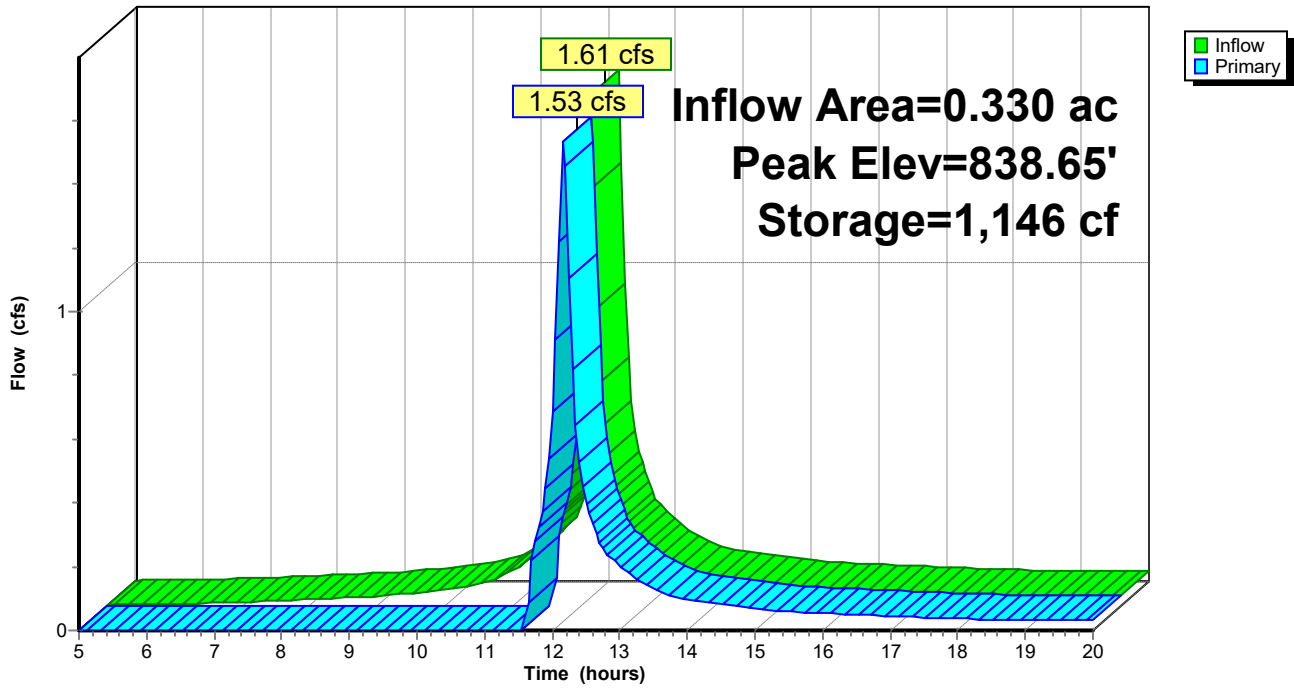

Summary for Link 4L: EX POA / A

Inflow Area = 18.510 ac, 0.00% Impervious, Inflow Depth > 3.11" for 25-Year event
Inflow = 32.19 cfs @ 12.53 hrs, Volume= 4.801 af
Primary = 32.19 cfs @ 12.53 hrs, Volume= 4.801 af, Atten= 0%, Lag= 0.0 min

Primary outflow = Inflow, Time Span= 5.00-20.00 hrs, dt= 0.05 hrs

Link 4L: EX POA / A

Hydrograph

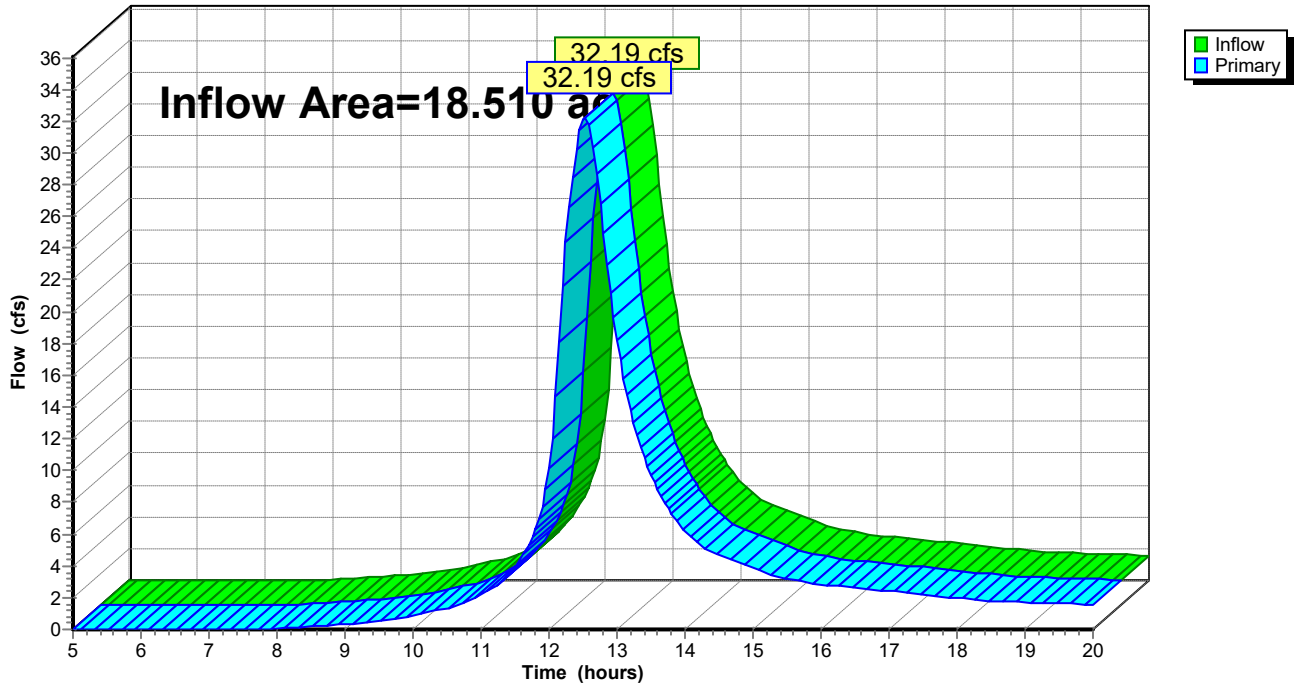

Summary for Link 15L: PR POA / A

Inflow Area = 17.850 ac, 0.00% Impervious, Inflow Depth > 3.13" for 25-Year event
Inflow = 30.96 cfs @ 12.54 hrs, Volume= 4.649 af
Primary = 30.96 cfs @ 12.54 hrs, Volume= 4.649 af, Atten= 0%, Lag= 0.0 min

Primary outflow = Inflow, Time Span= 5.00-20.00 hrs, dt= 0.05 hrs

Link 15L: PR POA / A

Hydrograph

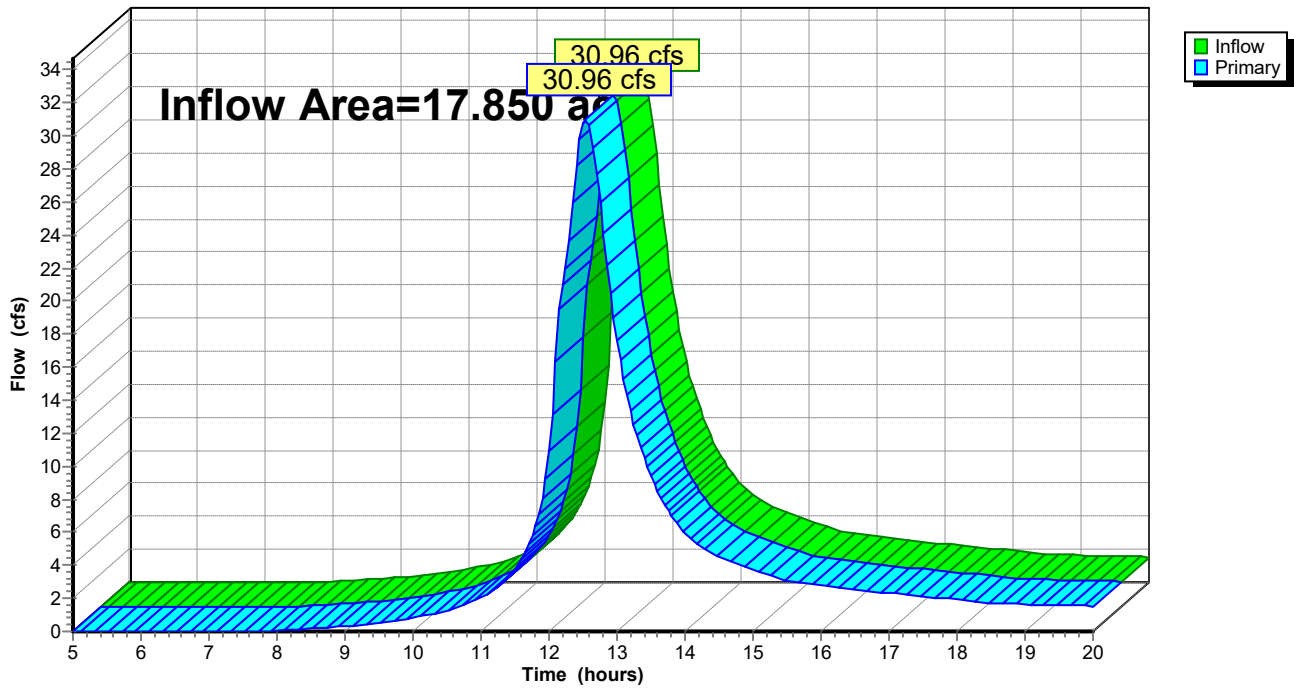

Summary for Link 18L: PR POA / B

Inflow Area = 6.180 ac, 0.00% Impervious, Inflow Depth > 2.88" for 25-Year event
Inflow = 17.85 cfs @ 12.23 hrs, Volume= 1.483 af
Primary = 17.85 cfs @ 12.23 hrs, Volume= 1.483 af, Atten= 0%, Lag= 0.0 min

Primary outflow = Inflow, Time Span= 5.00-20.00 hrs, dt= 0.05 hrs

Link 18L: PR POA / B

Hydrograph

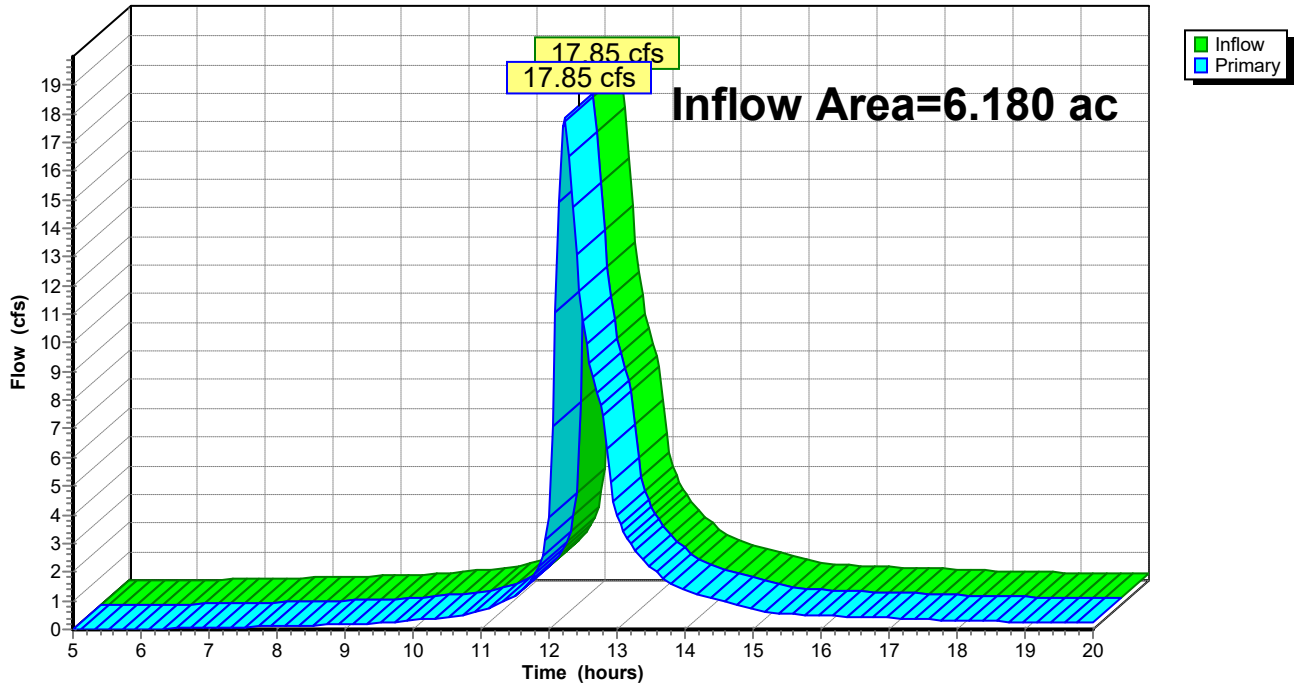

Summary for Subcatchment 1S: EXWS-10

Runoff = 9.63 cfs @ 12.22 hrs, Volume= 0.850 af, Depth> 4.15"
Routed to Link 4L : EX POA / A

Runoff by SCS TR-20 method, UH=SCS, Weighted-CN, Time Span= 5.00-20.00 hrs, dt= 0.05 hrs
NOAA 24-hr D 50-Year Rainfall=7.28"

Area (ac)	CN	Description
* 2.460	76	
2.460		100.00% Pervious Area

Tc (min)	Length (feet)	Slope (ft/ft)	Velocity (ft/sec)	Capacity (cfs)	Description
14.2					Direct Entry,

Subcatchment 1S: EXWS-10

Hydrograph

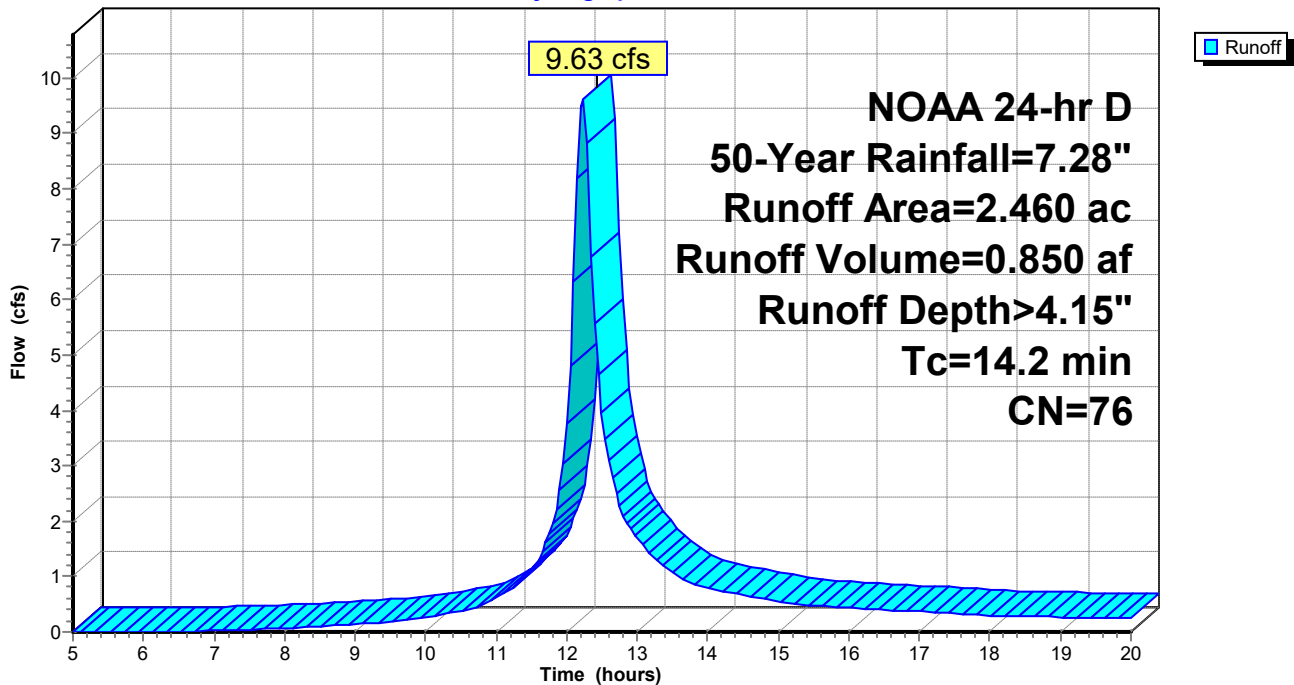

Summary for Subcatchment 2S: EXWS-11

Runoff = 35.97 cfs @ 12.55 hrs, Volume= 5.069 af, Depth> 3.79"
Routed to Link 4L : EX POA / A

Runoff by SCS TR-20 method, UH=SCS, Weighted-CN, Time Span= 5.00-20.00 hrs, dt= 0.05 hrs
NOAA 24-hr D 50-Year Rainfall=7.28"

Area (ac)	CN	Description
* 16.050	73	
16.050		100.00% Pervious Area

Tc (min)	Length (feet)	Slope (ft/ft)	Velocity (ft/sec)	Capacity (cfs)	Description
39.6					Direct Entry,

Subcatchment 2S: EXWS-11

Hydrograph

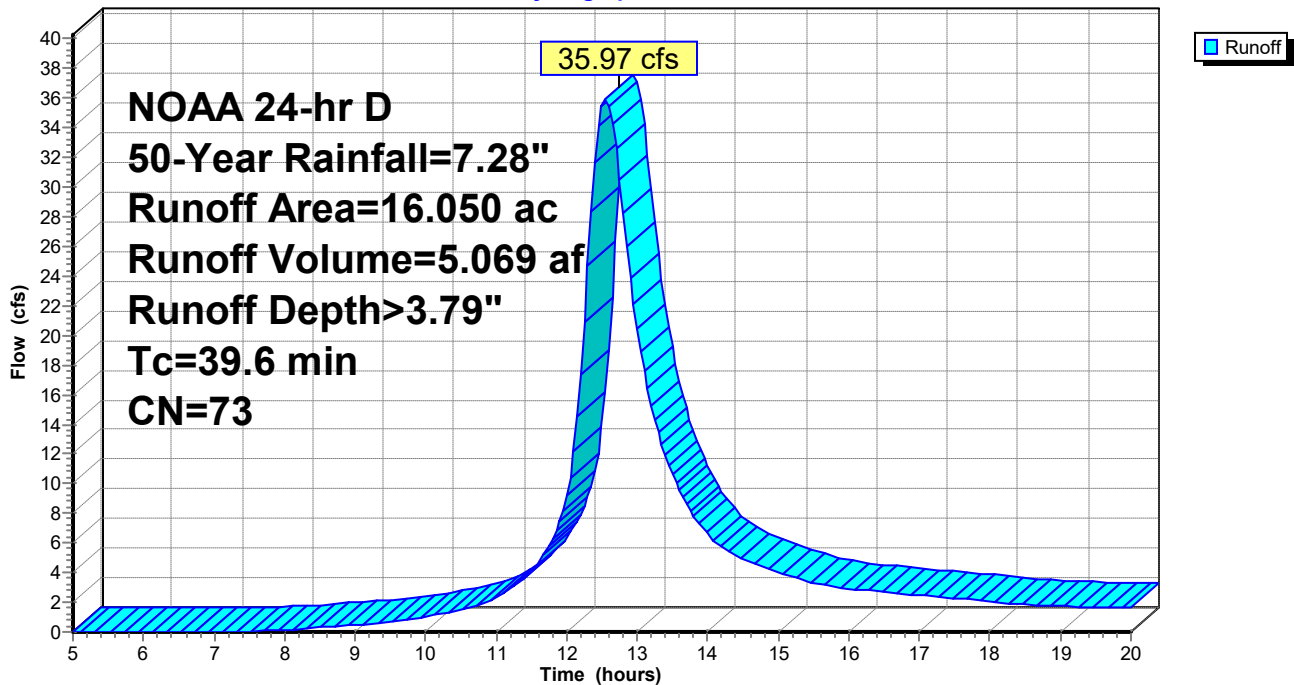

Summary for Subcatchment 5S: EXWS-20 / B

Runoff = 21.63 cfs @ 12.23 hrs, Volume= 1.999 af, Depth> 4.80"

Runoff by SCS TR-20 method, UH=SCS, Weighted-CN, Time Span= 5.00-20.00 hrs, dt= 0.05 hrs
NOAA 24-hr D 50-Year Rainfall=7.28"

Area (ac)	CN	Description
* 5.000	82	
5.000		100.00% Pervious Area

Tc (min)	Length (feet)	Slope (ft/ft)	Velocity (ft/sec)	Capacity (cfs)	Description
14.9					Direct Entry,

Subcatchment 5S: EXWS-20 / B

Hydrograph

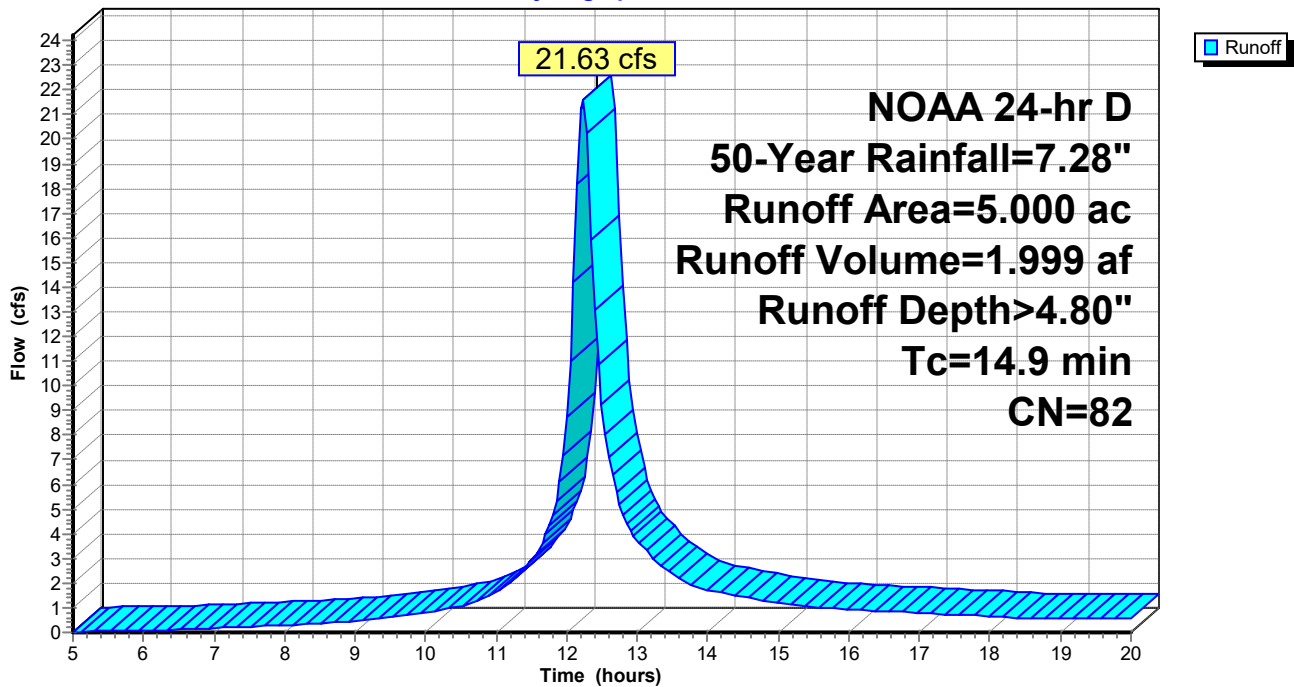

Summary for Subcatchment 6S: EXWS-30 / C

Runoff = 6.75 cfs @ 12.22 hrs, Volume= 0.592 af, Depth> 4.25"

Runoff by SCS TR-20 method, UH=SCS, Weighted-CN, Time Span= 5.00-20.00 hrs, dt= 0.05 hrs
NOAA 24-hr D 50-Year Rainfall=7.28"

Area (ac)	CN	Description
* 1.670	77	
1.670		100.00% Pervious Area

Tc (min)	Length (feet)	Slope (ft/ft)	Velocity (ft/sec)	Capacity (cfs)	Description
14.0					Direct Entry,

Subcatchment 6S: EXWS-30 / C

Hydrograph

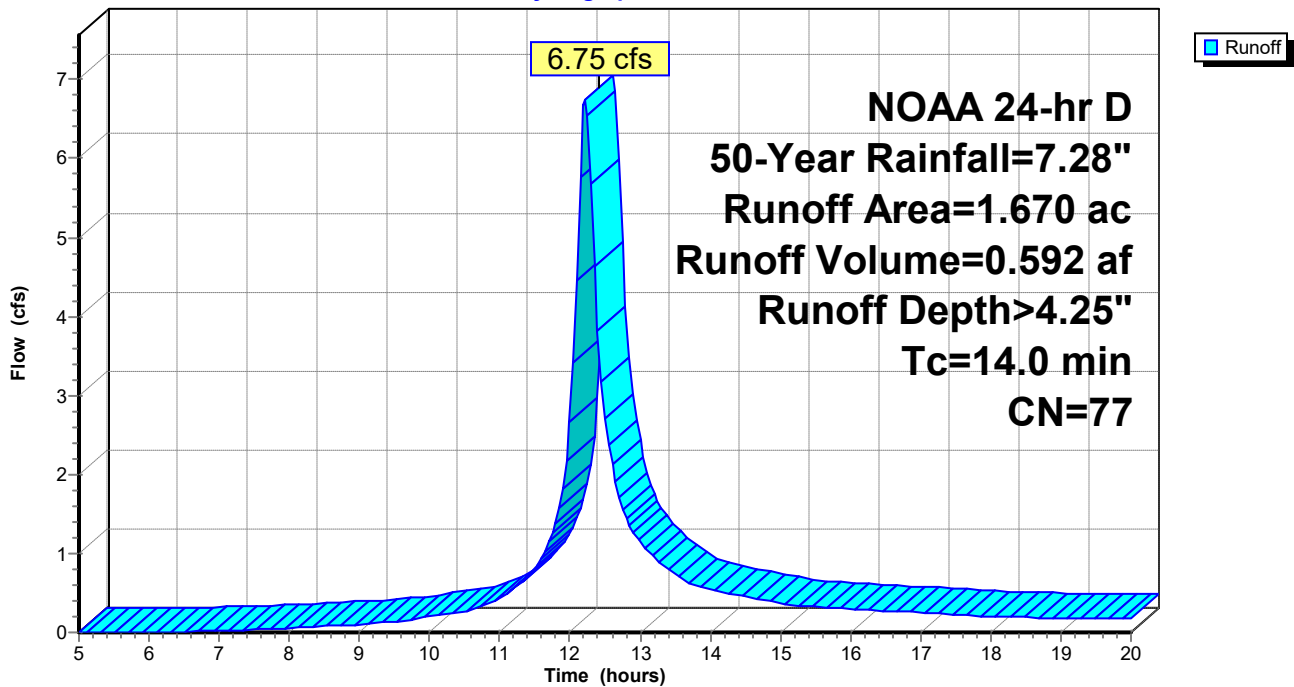

Summary for Subcatchment 7S: PRWS-10

Runoff = 7.95 cfs @ 12.15 hrs, Volume= 0.583 af, Depth> 4.37"
Routed to Link 15L : PR POA / A

Runoff by SCS TR-20 method, UH=SCS, Weighted-CN, Time Span= 5.00-20.00 hrs, dt= 0.05 hrs
NOAA 24-hr D 50-Year Rainfall=7.28"

Area (ac)	CN	Description
* 1.600	78	
1.600		100.00% Pervious Area

Tc (min)	Length (feet)	Slope (ft/ft)	Velocity (ft/sec)	Capacity (cfs)	Description
8.2					Direct Entry,

Subcatchment 7S: PRWS-10

Hydrograph

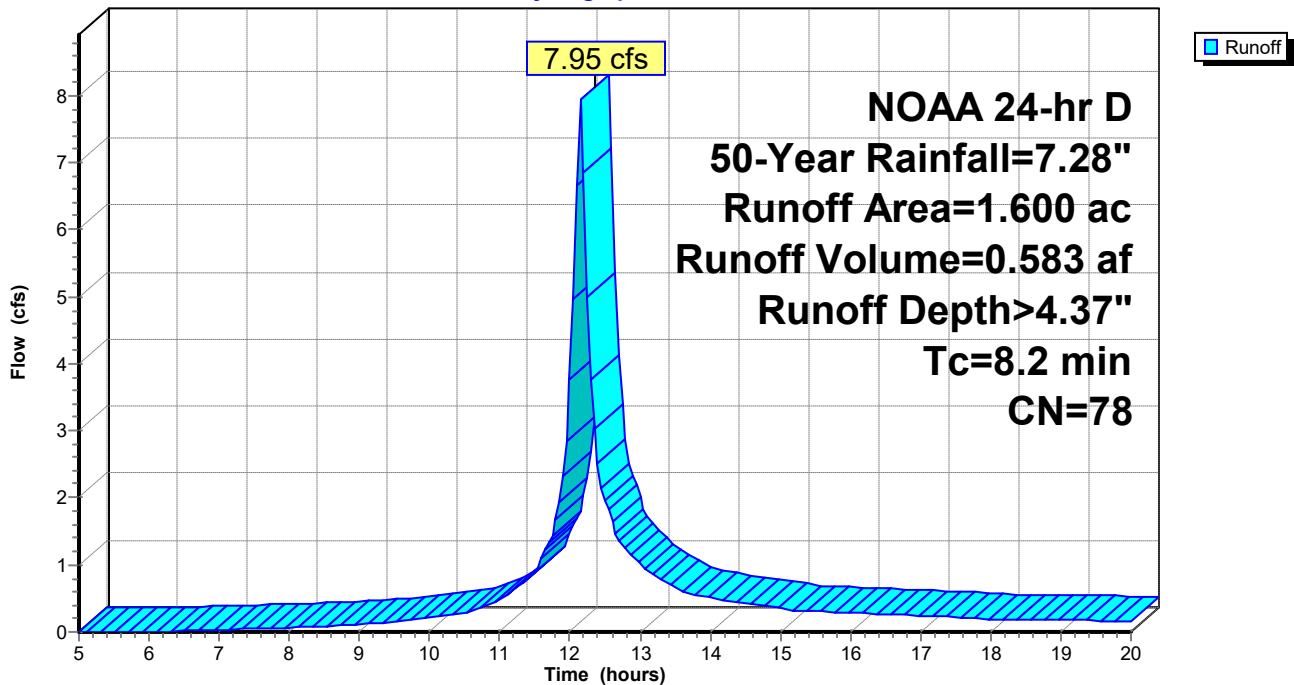

Summary for Subcatchment 8S: PRWS-11

Runoff = 35.73 cfs @ 12.54 hrs, Volume= 5.028 af, Depth> 3.79"
Routed to Link 15L : PR POA / A

Runoff by SCS TR-20 method, UH=SCS, Weighted-CN, Time Span= 5.00-20.00 hrs, dt= 0.05 hrs
NOAA 24-hr D 50-Year Rainfall=7.28"

Table with 3 columns: Area (ac), CN, Description. Row 1: 15.920, 73, 100.00% Pervious Area

Table with 7 columns: Tc (min), Length (feet), Slope (ft/ft), Velocity (ft/sec), Capacity (cfs), Description. Row 1: 39.5, Direct Entry,

Subcatchment 8S: PRWS-11

Hydrograph

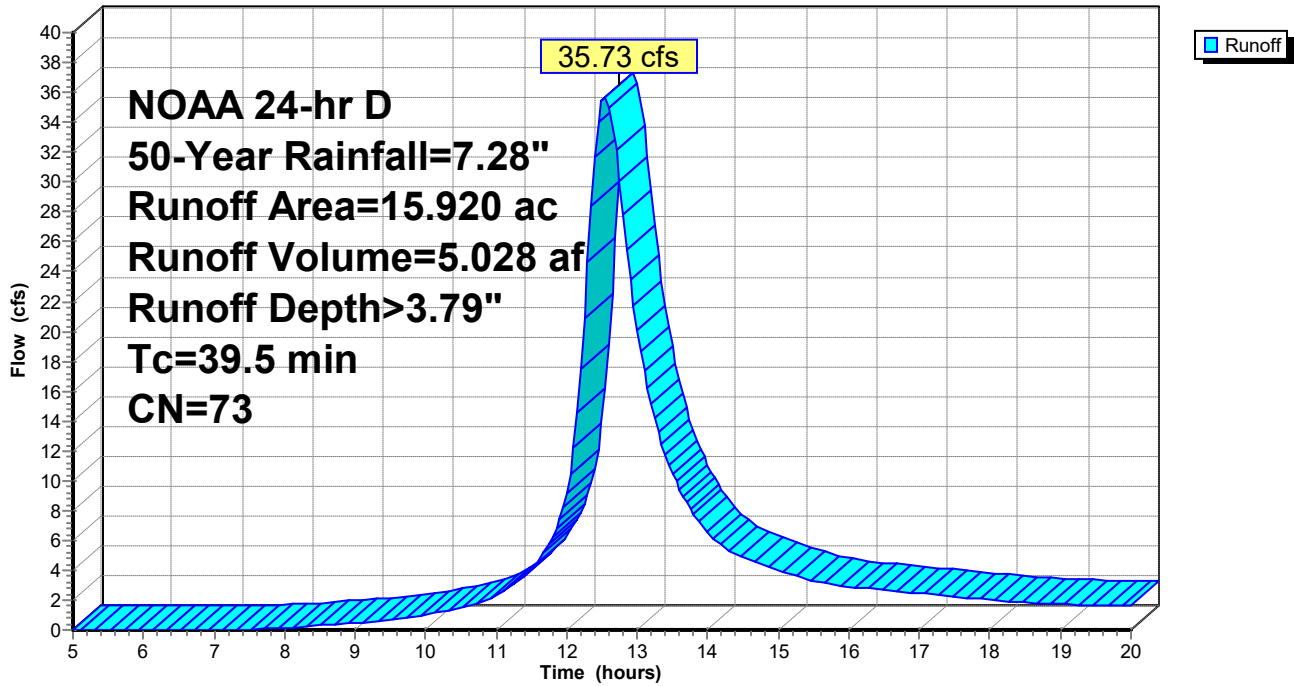

Summary for Subcatchment 10S: PRWS-20

Runoff = 10.90 cfs @ 12.24 hrs, Volume= 1.031 af, Depth> 4.80"
Routed to Link 18L : PR POA / B

Runoff by SCS TR-20 method, UH=SCS, Weighted-CN, Time Span= 5.00-20.00 hrs, dt= 0.05 hrs
NOAA 24-hr D 50-Year Rainfall=7.28"

Area (ac)	CN	Description
* 2.580	82	
2.580		100.00% Pervious Area

Tc (min)	Length (feet)	Slope (ft/ft)	Velocity (ft/sec)	Capacity (cfs)	Description
15.9					Direct Entry,

Subcatchment 10S: PRWS-20

Hydrograph

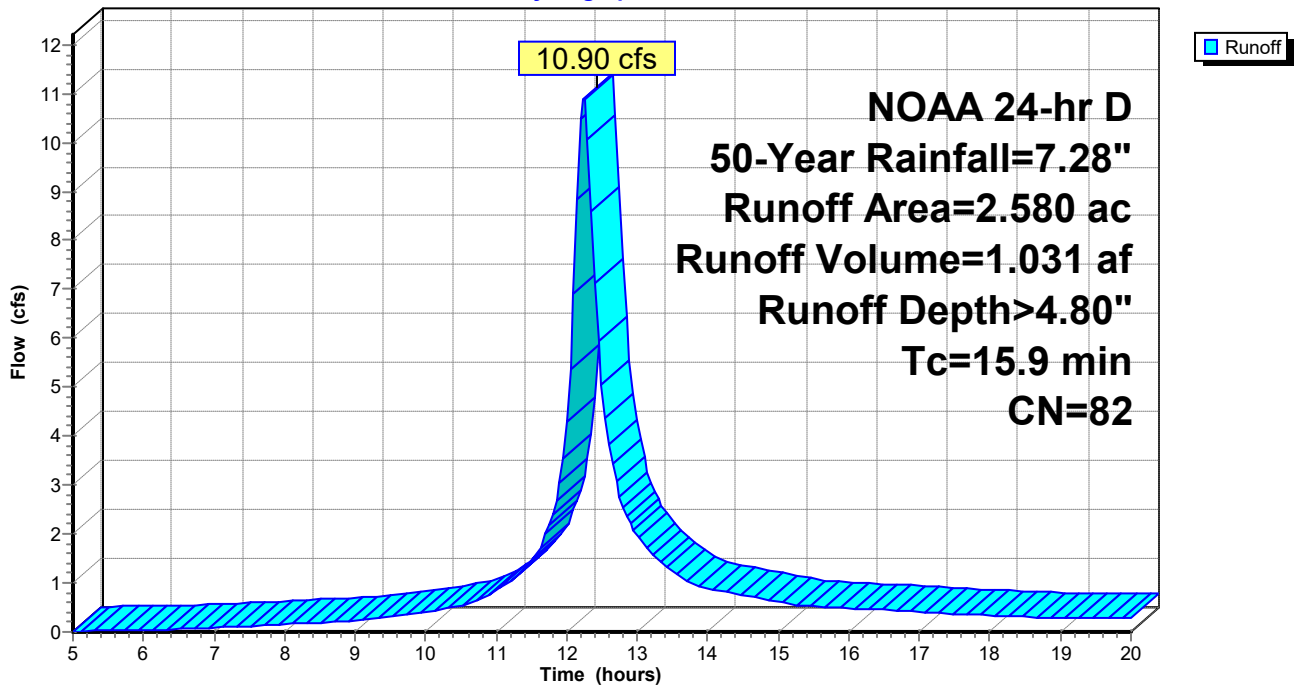

Summary for Subcatchment 11S: PRWS-21

Runoff = 16.09 cfs @ 12.16 hrs, Volume= 1.316 af, Depth> 5.56"
Routed to Pond 16P : DET 210

Runoff by SCS TR-20 method, UH=SCS, Weighted-CN, Time Span= 5.00-20.00 hrs, dt= 0.05 hrs
NOAA 24-hr D 50-Year Rainfall=7.28"

Area (ac)	CN	Description
* 2.840	89	
2.840		100.00% Pervious Area

Tc (min)	Length (feet)	Slope (ft/ft)	Velocity (ft/sec)	Capacity (cfs)	Description
9.4					Direct Entry,

Subcatchment 11S: PRWS-21

Hydrograph

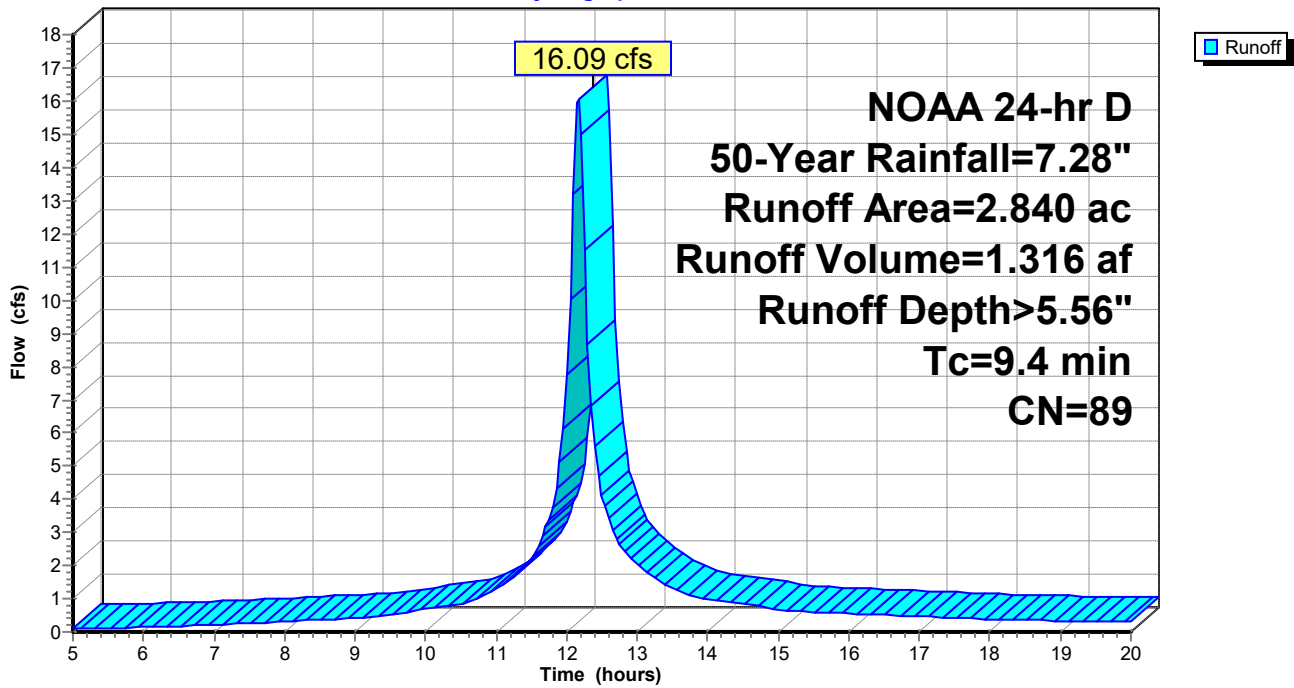

Summary for Subcatchment 12S: PRWS-22

Runoff = 4.31 cfs @ 12.17 hrs, Volume= 0.359 af, Depth> 5.66"
Routed to Pond 17P : DET 220

Runoff by SCS TR-20 method, UH=SCS, Weighted-CN, Time Span= 5.00-20.00 hrs, dt= 0.05 hrs
NOAA 24-hr D 50-Year Rainfall=7.28"

Area (ac)	CN	Description
* 0.760	90	
0.760		100.00% Pervious Area

Tc (min)	Length (feet)	Slope (ft/ft)	Velocity (ft/sec)	Capacity (cfs)	Description
9.7					Direct Entry,

Subcatchment 12S: PRWS-22

Hydrograph

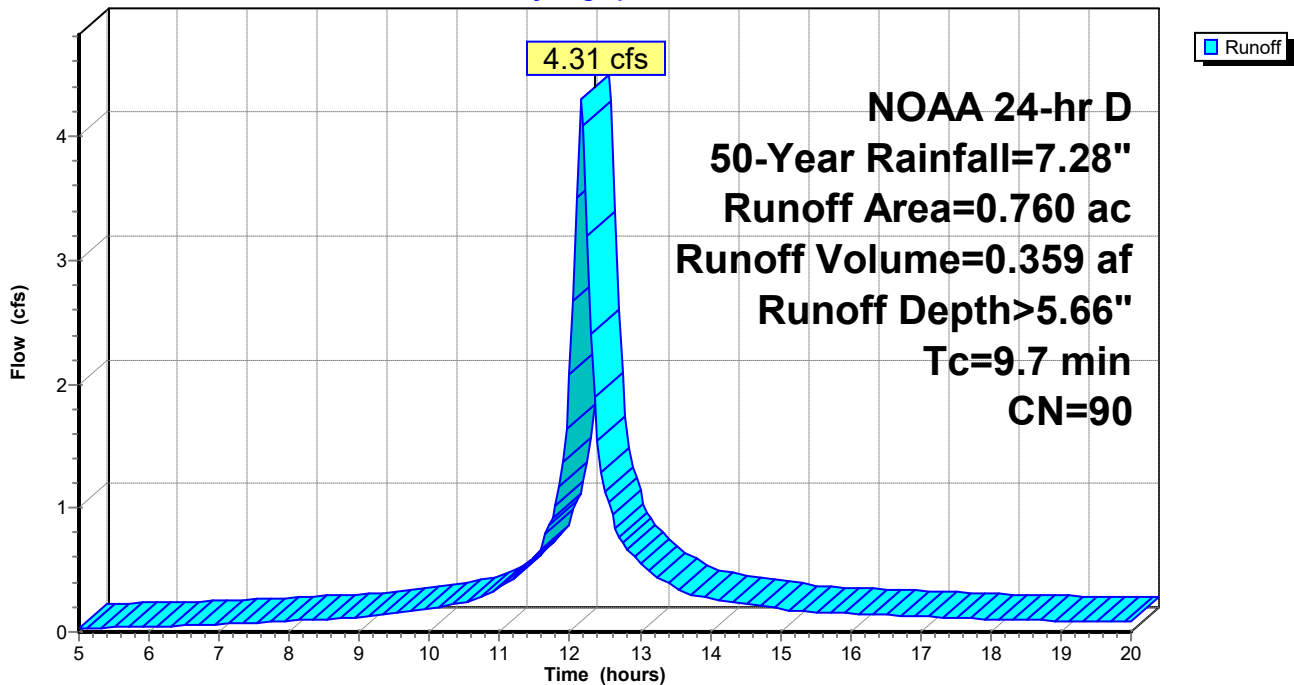

Summary for Subcatchment 13S: PRWS-30 / C

Runoff = 4.74 cfs @ 12.21 hrs, Volume= 0.411 af, Depth> 4.36"

Runoff by SCS TR-20 method, UH=SCS, Weighted-CN, Time Span= 5.00-20.00 hrs, dt= 0.05 hrs
NOAA 24-hr D 50-Year Rainfall=7.28"

Area (ac)	CN	Description
* 1.130	78	
1.130		100.00% Pervious Area

Tc (min)	Length (feet)	Slope (ft/ft)	Velocity (ft/sec)	Capacity (cfs)	Description
13.4					Direct Entry,

Subcatchment 13S: PRWS-30 / C

Hydrograph

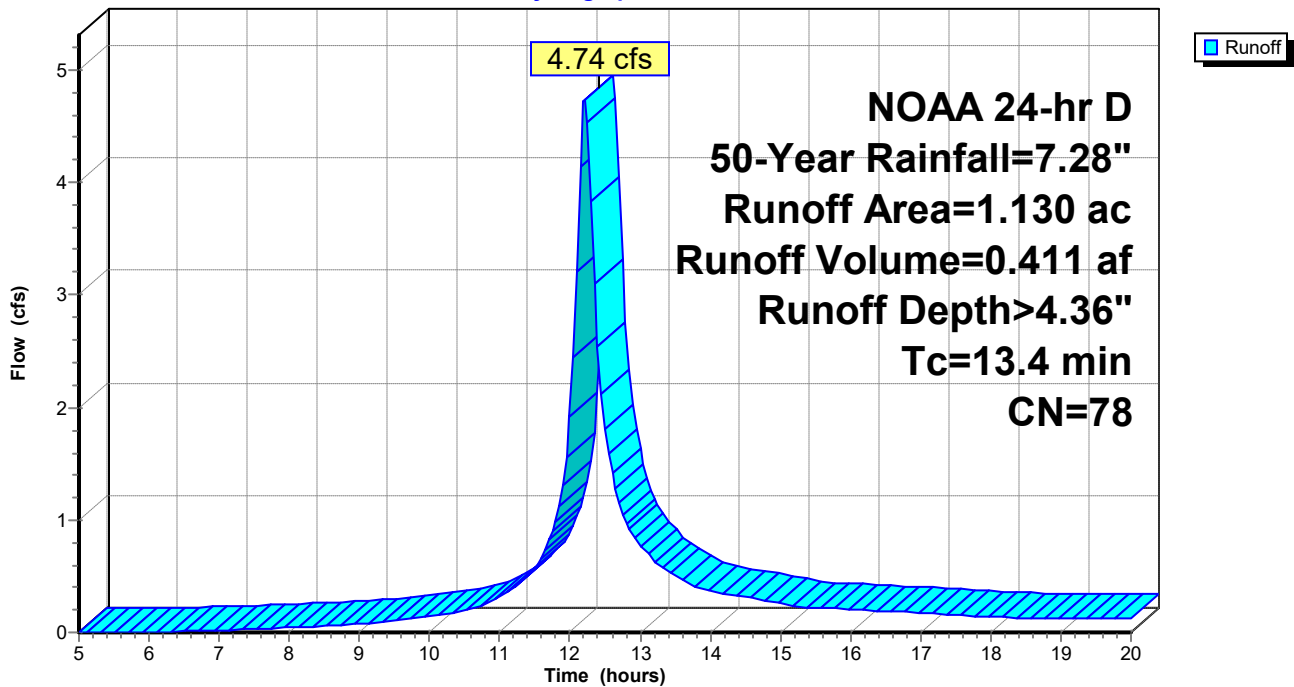

WR-Model06

Prepared by SLR International Corporation
HydroCAD® 10.20-7a s/n 08105 © 2025 HydroCAD Software Solutions LLC

NOAA 24-hr D 50-Year Rainfall=7.28"

Printed 7/24/2025

Page 112

Summary for Subcatchment 20S: PRWS-14

Runoff = 1.89 cfs @ 12.15 hrs, Volume= 0.141 af, Depth> 5.14"
Routed to Pond 23P : WQ 140

Runoff by SCS TR-20 method, UH=SCS, Weighted-CN, Time Span= 5.00-20.00 hrs, dt= 0.05 hrs
NOAA 24-hr D 50-Year Rainfall=7.28"

Area (ac)	CN	Description
* 0.330	85	
0.330		100.00% Pervious Area

Tc (min)	Length (feet)	Slope (ft/ft)	Velocity (ft/sec)	Capacity (cfs)	Description
7.7					Direct Entry,

Subcatchment 20S: PRWS-14

Hydrograph

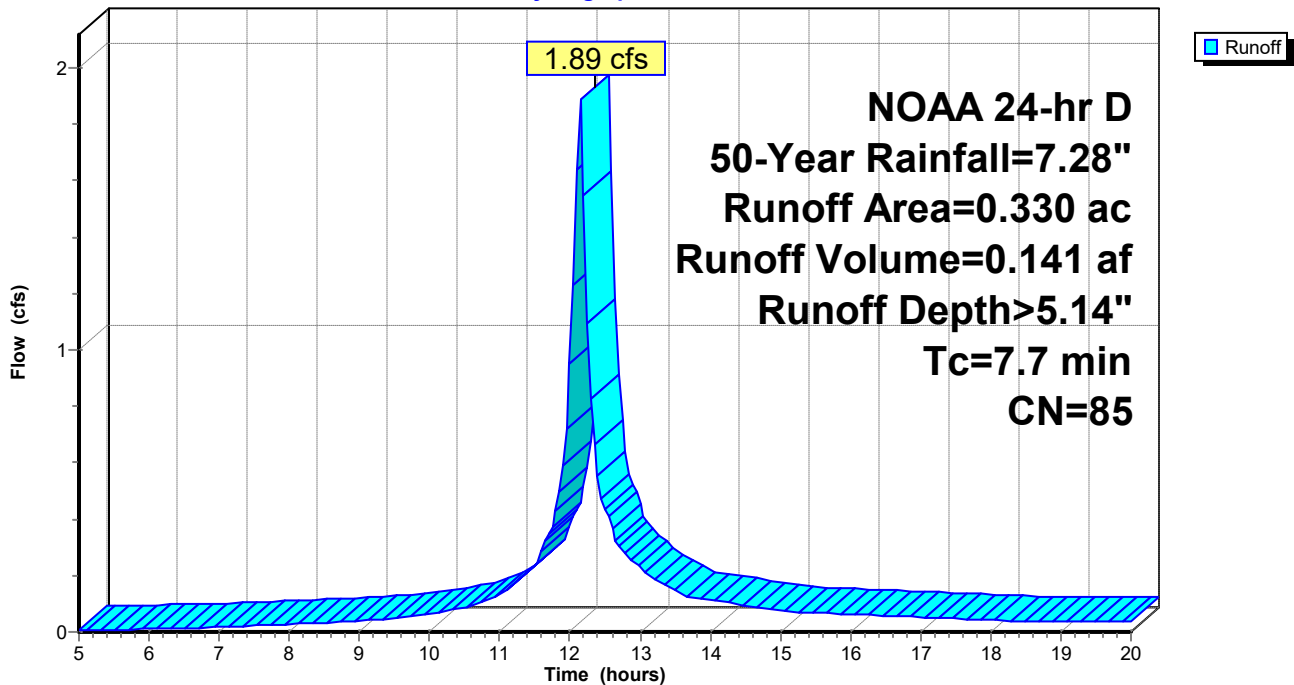

Summary for Pond 16P: DET 210

Inflow Area = 2.840 ac, 0.00% Impervious, Inflow Depth > 5.56" for 50-Year event
 Inflow = 16.09 cfs @ 12.16 hrs, Volume= 1.316 af
 Outflow = 6.79 cfs @ 12.36 hrs, Volume= 1.212 af, Atten= 58%, Lag= 11.7 min
 Discarded = 0.70 cfs @ 12.36 hrs, Volume= 0.612 af
 Primary = 6.09 cfs @ 12.36 hrs, Volume= 0.600 af
 Routed to Link 18L : PR POA / B
 Secondary = 0.00 cfs @ 5.00 hrs, Volume= 0.000 af
 Routed to Link 18L : PR POA / B

Routing by Stor-Ind method, Time Span= 5.00-20.00 hrs, dt= 0.05 hrs
 Peak Elev= 816.83' @ 12.36 hrs Surf.Area= 10,050 sf Storage= 16,124 cf

Plug-Flow detention time= 67.2 min calculated for 1.212 af (92% of inflow)
 Center-of-Mass det. time= 38.4 min (794.8 - 756.4)

Volume	Invert	Avail.Storage	Storage Description
#1	815.00'	28,886 cf	Custom Stage Data (Conic) Listed below (Recalc)
Elevation (feet)	Surf.Area (sq-ft)	Inc.Store (cubic-feet)	Cum.Store (cubic-feet) Wet.Area (sq-ft)
815.00	7,672	0	0 7,672
816.00	8,907	8,282	8,282 8,948
817.00	10,296	9,593	17,875 10,380
818.00	11,741	11,011	28,886 11,872

Device	Routing	Invert	Outlet Devices
#1	Discarded	815.00'	3.000 in/hr Exfiltration over Surface area
#2	Primary	814.50'	15.0" Round Culvert L= 127.0' CPP, projecting, no headwall, Ke= 0.900 Inlet / Outlet Invert= 814.50' / 806.40' S= 0.0638 '/' Cc= 0.900 n= 0.012, Flow Area= 1.23 sf
#3	Device 2	815.90'	14.0' long Sharp-Crested Rectangular Weir 2 End Contraction(s)
#4	Secondary	817.20'	10.0' long + 3.0 ' SideZ x 8.0' breadth Broad-Crested Rectangular Weir Head (feet) 0.20 0.40 0.60 0.80 1.00 1.20 1.40 1.60 1.80 2.00 2.50 3.00 3.50 4.00 4.50 5.00 5.50 Coef. (English) 2.43 2.54 2.70 2.69 2.68 2.68 2.66 2.64 2.64 2.64 2.65 2.65 2.66 2.66 2.68 2.70 2.74

Discarded OutFlow Max=0.70 cfs @ 12.36 hrs HW=816.83' (Free Discharge)
 ↑1=Exfiltration (Exfiltration Controls 0.70 cfs)

Primary OutFlow Max=6.08 cfs @ 12.36 hrs HW=816.83' (Free Discharge)
 ↑2=Culvert (Inlet Controls 6.08 cfs @ 4.96 fps)
 ↑3=Sharp-Crested Rectangular Weir (Passes 6.08 cfs of 40.27 cfs potential flow)

Secondary OutFlow Max=0.00 cfs @ 5.00 hrs HW=815.00' (Free Discharge)
 ↑4=Broad-Crested Rectangular Weir (Controls 0.00 cfs)

Pond 16P: DET 210

Hydrograph

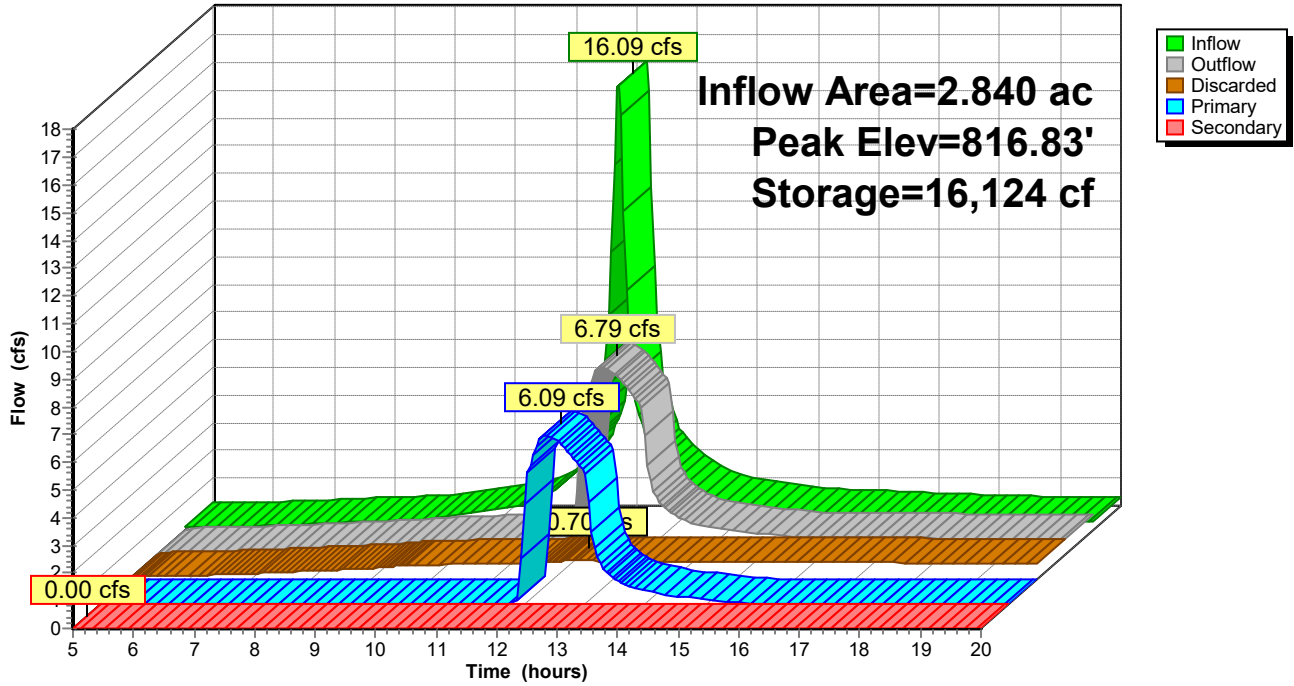

Summary for Pond 17P: DET 220

Inflow Area = 0.760 ac, 0.00% Impervious, Inflow Depth > 5.66" for 50-Year event
 Inflow = 4.31 cfs @ 12.17 hrs, Volume= 0.359 af
 Outflow = 4.16 cfs @ 12.20 hrs, Volume= 0.306 af, Atten= 3%, Lag= 1.8 min
 Discarded = 0.10 cfs @ 12.20 hrs, Volume= 0.090 af
 Primary = 4.06 cfs @ 12.20 hrs, Volume= 0.216 af
 Routed to Link 18L : PR POA / B
 Secondary = 0.00 cfs @ 5.00 hrs, Volume= 0.000 af
 Routed to Link 18L : PR POA / B

Routing by Stor-Ind method, Time Span= 5.00-20.00 hrs, dt= 0.05 hrs
 Peak Elev= 802.98' @ 12.20 hrs Surf.Area= 2,790 sf Storage= 4,074 cf

Plug-Flow detention time= 85.7 min calculated for 0.305 af (85% of inflow)
 Center-of-Mass det. time= 40.4 min (794.7 - 754.3)

Volume	Invert	Avail.Storage	Storage Description		
#1	801.00'	7,722 cf	Custom Stage Data (Conic) Listed below (Recalc)		
Elevation (feet)	Surf.Area (sq-ft)	Inc.Store (cubic-feet)	Cum.Store (cubic-feet)	Wet.Area (sq-ft)	
801.00	1,433	0	0	1,433	
802.00	2,039	1,727	1,727	2,057	
803.00	2,810	2,414	4,141	2,847	
804.00	4,412	3,581	7,722	4,463	

Device	Routing	Invert	Outlet Devices	
#1	Discarded	801.00'	1.580 in/hr Exfiltration over Surface area	
#2	Primary	800.50'	15.0" Round Culvert L= 39.0' CPP, projecting, no headwall, Ke= 0.900 Inlet / Outlet Invert= 800.50' / 800.00' S= 0.0128 '/' Cc= 0.900 n= 0.012, Flow Area= 1.23 sf	
#3	Device 2	802.20'	6.0" Vert. Orifice/Grate C= 0.600 Limited to weir flow at low heads	
#4	Device 2	802.80'	14.0' long Sharp-Crested Rectangular Weir 2 End Contraction(s)	
#5	Secondary	803.00'	10.0' long + 3.0 ' SideZ x 8.0' breadth Broad-Crested Rectangular Weir Head (feet) 0.20 0.40 0.60 0.80 1.00 1.20 1.40 1.60 1.80 2.00 2.50 3.00 3.50 4.00 4.50 5.00 5.50 Coef. (English) 2.43 2.54 2.70 2.69 2.68 2.68 2.66 2.64 2.64 2.64 2.65 2.65 2.66 2.66 2.68 2.70 2.74	

Discarded OutFlow Max=0.10 cfs @ 12.20 hrs HW=802.97' (Free Discharge)
 ↑1=Exfiltration (Exfiltration Controls 0.10 cfs)

Primary OutFlow Max=4.02 cfs @ 12.20 hrs HW=802.97' (Free Discharge)
 ↑2=Culvert (Passes 4.02 cfs of 6.34 cfs potential flow)
 ↑3=Orifice/Grate (Orifice Controls 0.68 cfs @ 3.49 fps)
 ↑4=Sharp-Crested Rectangular Weir (Weir Controls 3.34 cfs @ 1.37 fps)

Secondary OutFlow Max=0.00 cfs @ 5.00 hrs HW=801.00' (Free Discharge)
 ↑5=Broad-Crested Rectangular Weir (Controls 0.00 cfs)

Pond 17P: DET 220

Hydrograph

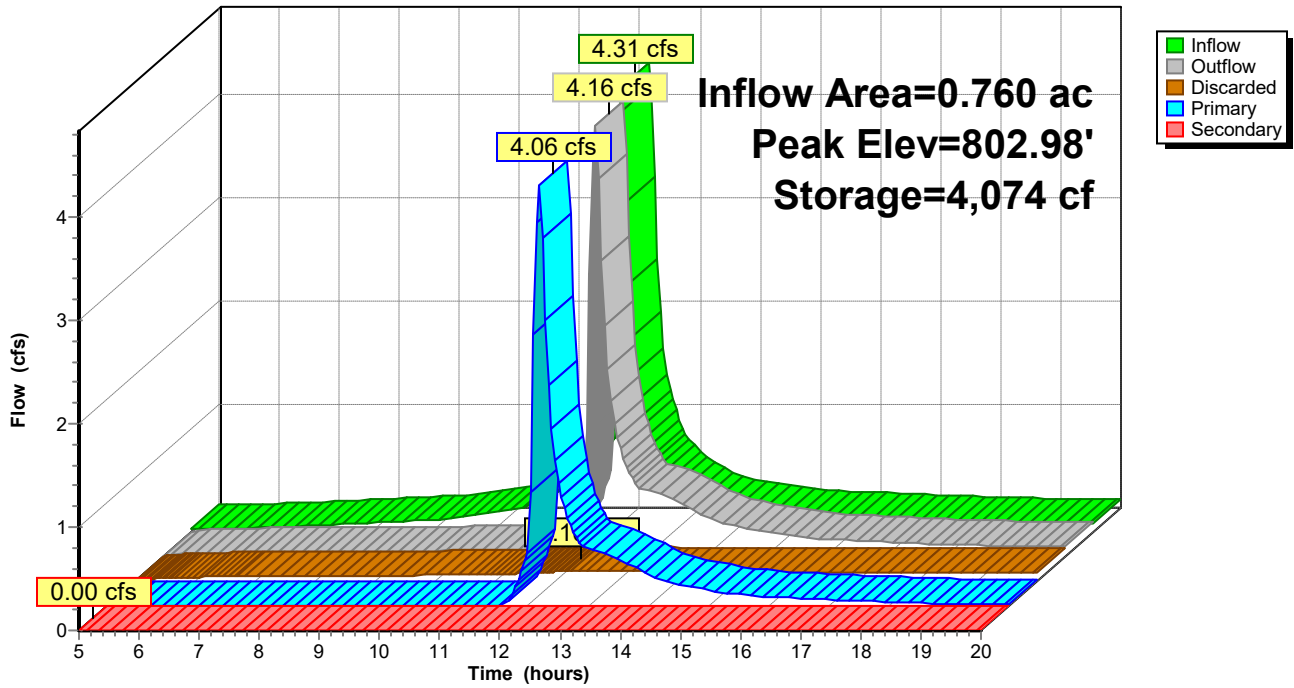

Summary for Pond 23P: WQ 140

Inflow Area = 0.330 ac, 0.00% Impervious, Inflow Depth > 5.14" for 50-Year event
 Inflow = 1.89 cfs @ 12.15 hrs, Volume= 0.141 af
 Outflow = 1.81 cfs @ 12.17 hrs, Volume= 0.119 af, Atten= 4%, Lag= 1.1 min
 Primary = 1.81 cfs @ 12.17 hrs, Volume= 0.119 af
 Routed to Link 15L : PR POA / A

Routing by Stor-Ind method, Time Span= 5.00-20.00 hrs, dt= 0.05 hrs
 Peak Elev= 838.67' @ 12.17 hrs Surf.Area= 1,163 sf Storage= 1,167 cf

Plug-Flow detention time= 84.8 min calculated for 0.118 af (84% of inflow)
 Center-of-Mass det. time= 37.2 min (801.5 - 764.3)

Volume	Invert	Avail.Storage	Storage Description
#1	837.50'	1,554 cf	Custom Stage Data (Prismatic) Listed below (Recalc)
Elevation (feet)	Surf.Area (sq-ft)	Inc.Store (cubic-feet)	Cum.Store (cubic-feet)
837.50	801	0	0
838.00	964	441	441
838.50	1,143	527	968
839.00	1,200	586	1,554

Device	Routing	Invert	Outlet Devices
#1	Primary	838.50'	10.0' long + 3.0 ' SideZ x 8.0' breadth Broad-Crested Rectangular Weir Head (feet) 0.20 0.40 0.60 0.80 1.00 1.20 1.40 1.60 1.80 2.00 2.50 3.00 3.50 4.00 4.50 5.00 5.50 Coef. (English) 2.43 2.54 2.70 2.69 2.68 2.68 2.66 2.64 2.64 2.64 2.65 2.65 2.66 2.66 2.68 2.70 2.74

Primary OutFlow Max=1.76 cfs @ 12.17 hrs HW=838.67' (Free Discharge)
 ↑1=**Broad-Crested Rectangular Weir** (Weir Controls 1.76 cfs @ 0.99 fps)

Pond 23P: WQ 140

Hydrograph

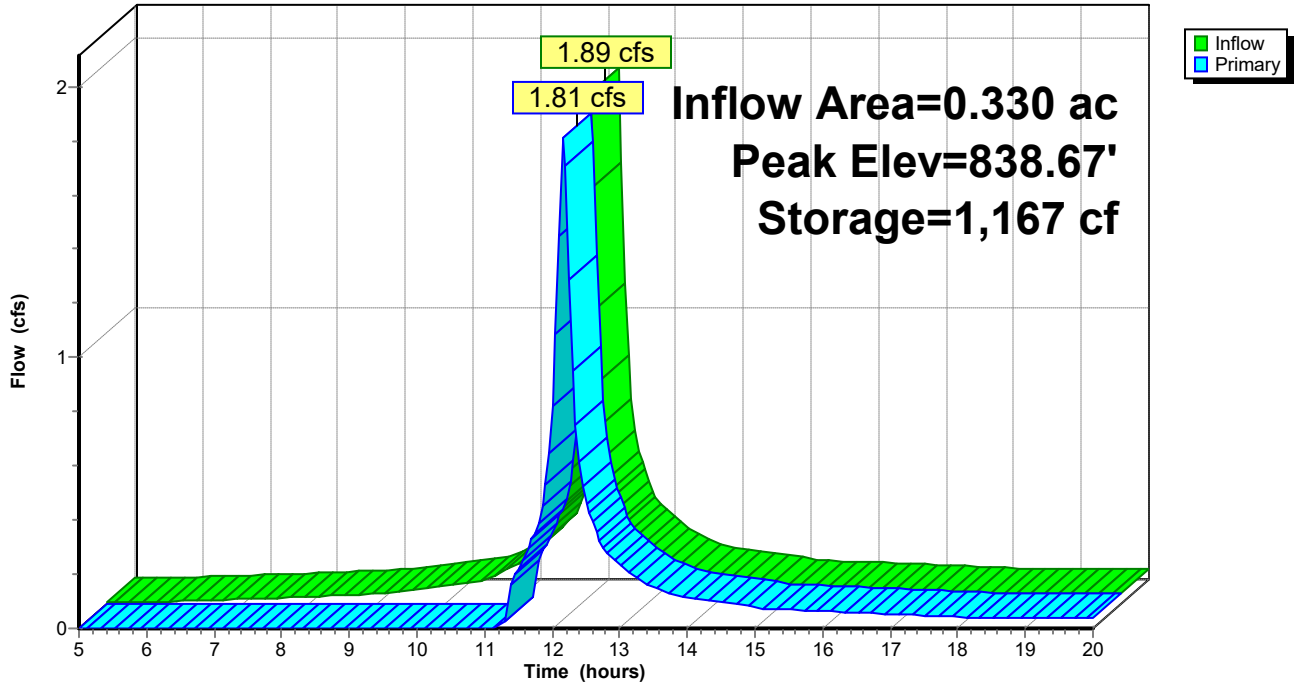

Summary for Link 4L: EX POA / A

Inflow Area = 18.510 ac, 0.00% Impervious, Inflow Depth > 3.84" for 50-Year event
Inflow = 39.55 cfs @ 12.52 hrs, Volume= 5.919 af
Primary = 39.55 cfs @ 12.52 hrs, Volume= 5.919 af, Atten= 0%, Lag= 0.0 min

Primary outflow = Inflow, Time Span= 5.00-20.00 hrs, dt= 0.05 hrs

Link 4L: EX POA / A

Hydrograph

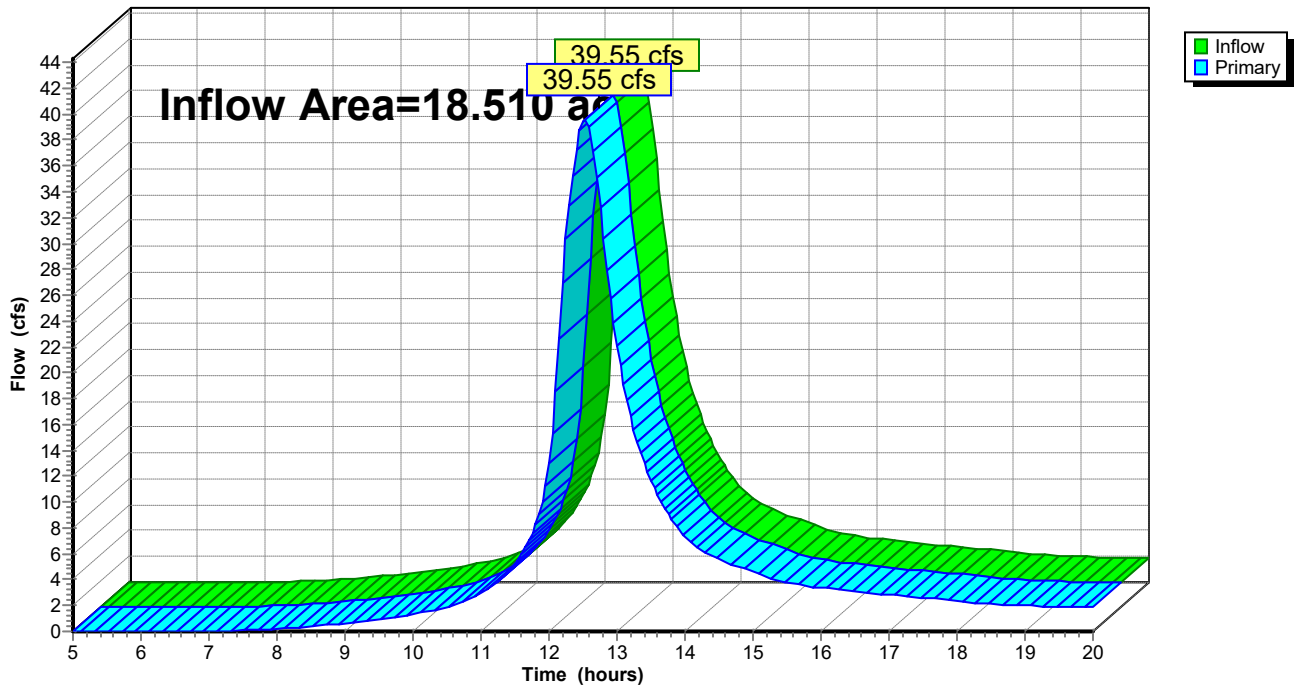

Summary for Link 15L: PR POA / A

Inflow Area = 17.850 ac, 0.00% Impervious, Inflow Depth > 3.85" for 50-Year event
Inflow = 38.03 cfs @ 12.53 hrs, Volume= 5.730 af
Primary = 38.03 cfs @ 12.53 hrs, Volume= 5.730 af, Atten= 0%, Lag= 0.0 min

Primary outflow = Inflow, Time Span= 5.00-20.00 hrs, dt= 0.05 hrs

Link 15L: PR POA / A

Hydrograph

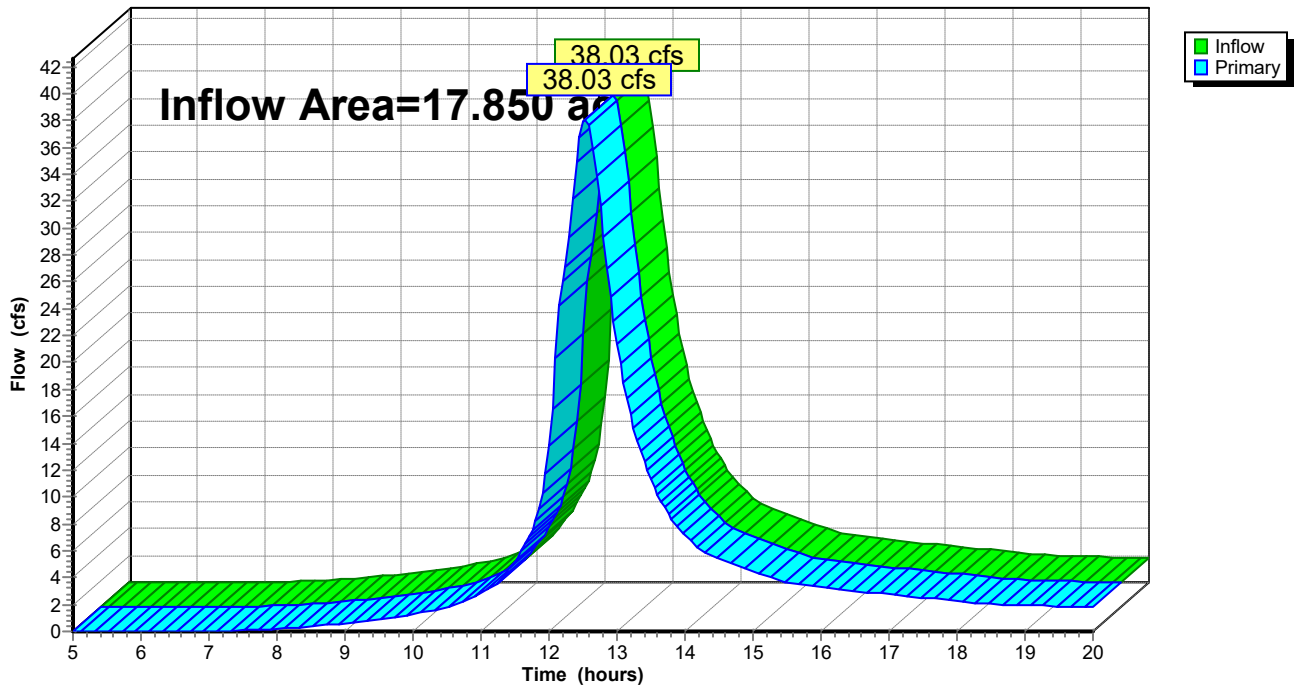

Summary for Link 18L: PR POA / B

Inflow Area = 6.180 ac, 0.00% Impervious, Inflow Depth > 3.59" for 50-Year event
Inflow = 20.52 cfs @ 12.23 hrs, Volume= 1.847 af
Primary = 20.52 cfs @ 12.23 hrs, Volume= 1.847 af, Atten= 0%, Lag= 0.0 min

Primary outflow = Inflow, Time Span= 5.00-20.00 hrs, dt= 0.05 hrs

Link 18L: PR POA / B

Hydrograph

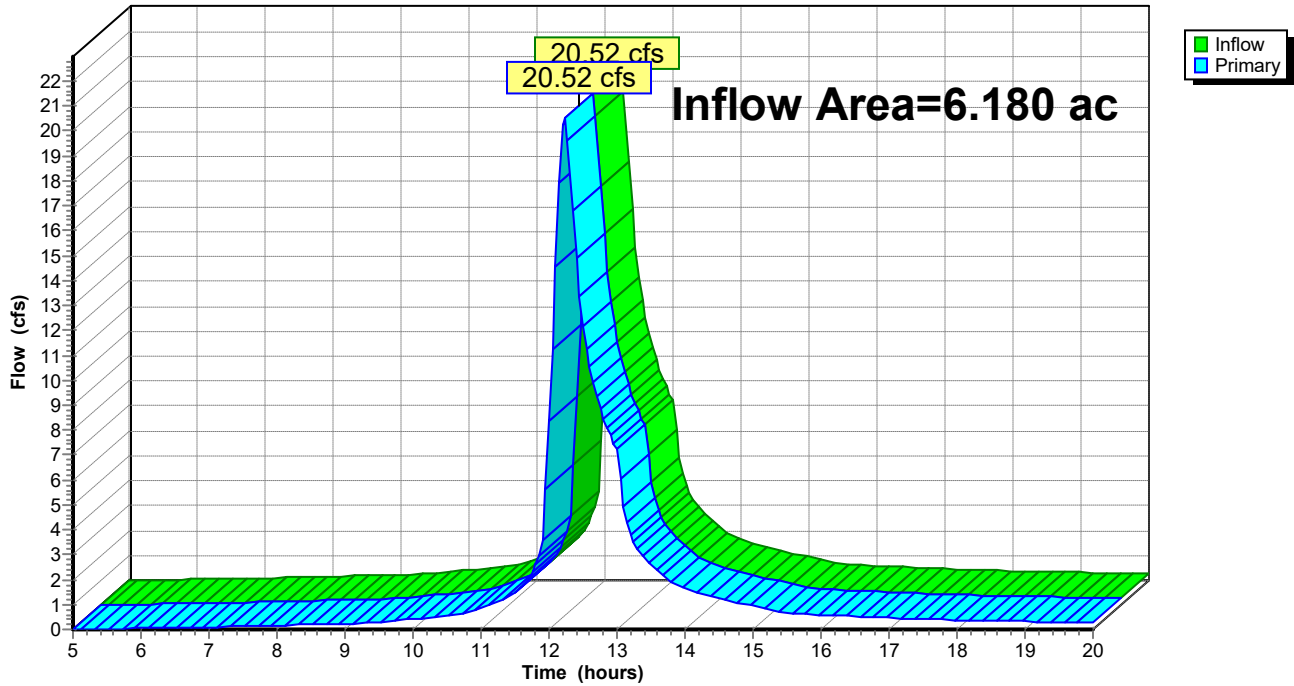

Summary for Subcatchment 1S: EXWS-10

Runoff = 11.59 cfs @ 12.22 hrs, Volume= 1.031 af, Depth> 5.03"
Routed to Link 4L : EX POA / A

Runoff by SCS TR-20 method, UH=SCS, Weighted-CN, Time Span= 5.00-20.00 hrs, dt= 0.05 hrs
NOAA 24-hr D 100-Year Rainfall=8.32"

Area (ac)	CN	Description
* 2.460	76	
2.460		100.00% Pervious Area

Tc (min)	Length (feet)	Slope (ft/ft)	Velocity (ft/sec)	Capacity (cfs)	Description
14.2					Direct Entry,

Subcatchment 1S: EXWS-10

Hydrograph

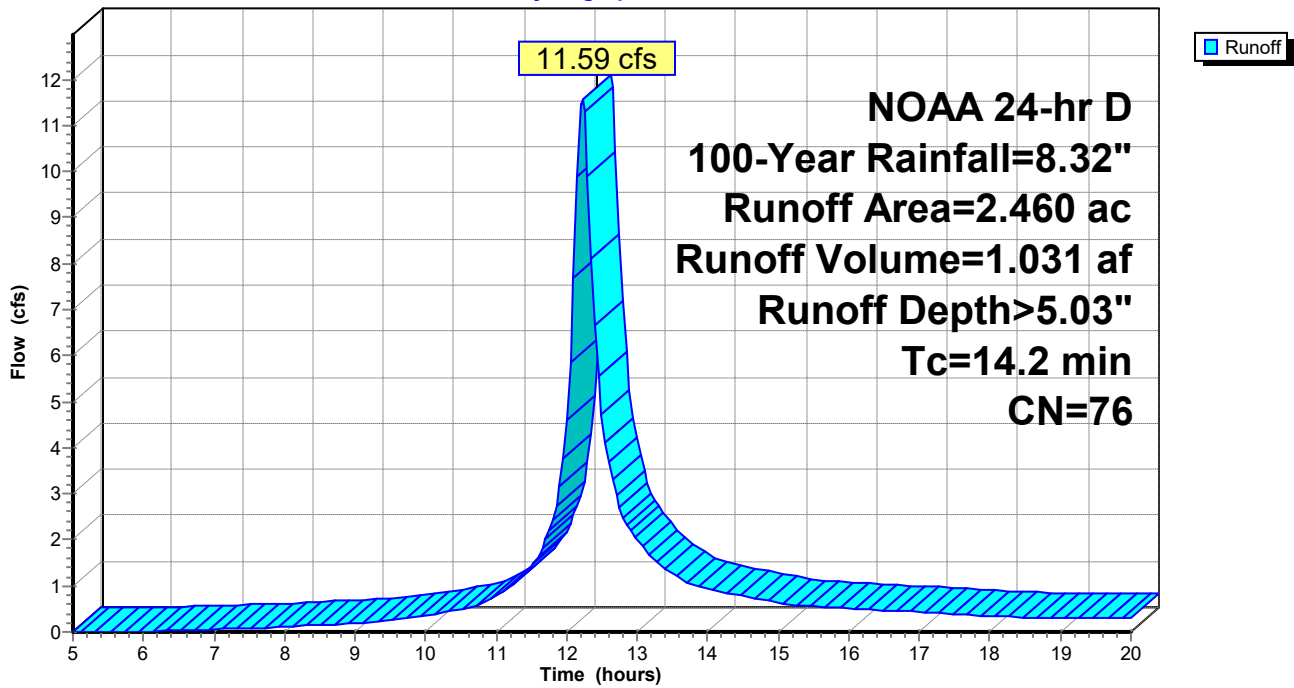

Summary for Subcatchment 2S: EXWS-11

Runoff = 43.82 cfs @ 12.55 hrs, Volume= 6.205 af, Depth> 4.64"
 Routed to Link 4L : EX POA / A

Runoff by SCS TR-20 method, UH=SCS, Weighted-CN, Time Span= 5.00-20.00 hrs, dt= 0.05 hrs
 NOAA 24-hr D 100-Year Rainfall=8.32"

Area (ac)	CN	Description
* 16.050	73	
16.050		100.00% Pervious Area

Tc (min)	Length (feet)	Slope (ft/ft)	Velocity (ft/sec)	Capacity (cfs)	Description
39.6					Direct Entry,

Subcatchment 2S: EXWS-11

Hydrograph

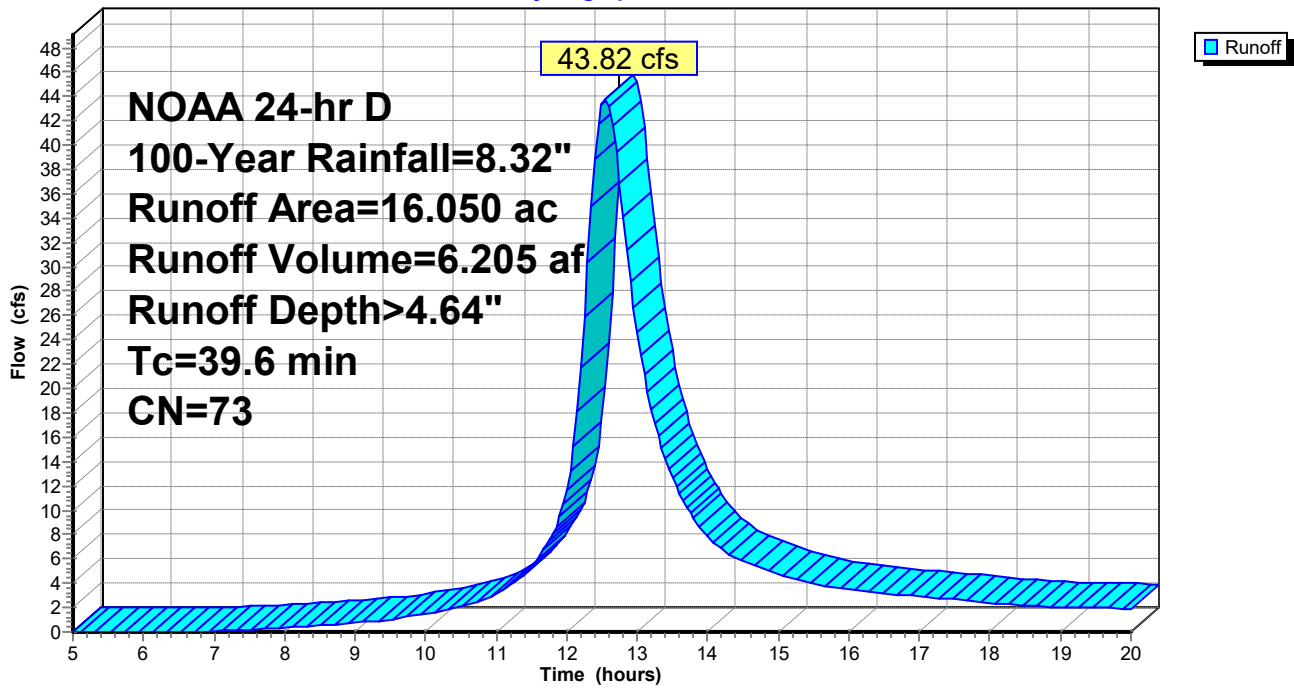

Summary for Subcatchment 5S: EXWS-20 / B

Runoff = 25.54 cfs @ 12.23 hrs, Volume= 2.383 af, Depth> 5.72"

Runoff by SCS TR-20 method, UH=SCS, Weighted-CN, Time Span= 5.00-20.00 hrs, dt= 0.05 hrs
NOAA 24-hr D 100-Year Rainfall=8.32"

Area (ac)	CN	Description
* 5.000	82	
5.000		100.00% Pervious Area

Tc (min)	Length (feet)	Slope (ft/ft)	Velocity (ft/sec)	Capacity (cfs)	Description
14.9					Direct Entry,

Subcatchment 5S: EXWS-20 / B

Hydrograph

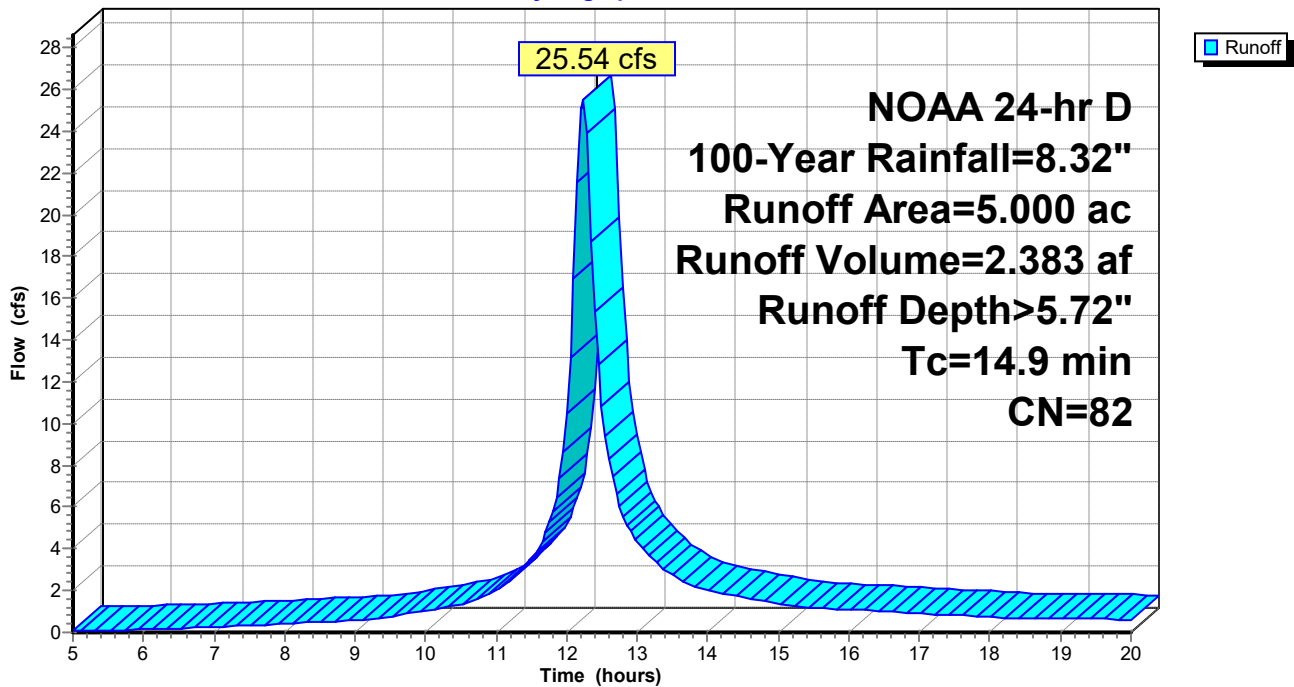

Summary for Subcatchment 6S: EXWS-30 / C

Runoff = 8.09 cfs @ 12.22 hrs, Volume= 0.716 af, Depth> 5.15"

Runoff by SCS TR-20 method, UH=SCS, Weighted-CN, Time Span= 5.00-20.00 hrs, dt= 0.05 hrs
NOAA 24-hr D 100-Year Rainfall=8.32"

Area (ac)	CN	Description
* 1.670	77	
1.670		100.00% Pervious Area

Tc (min)	Length (feet)	Slope (ft/ft)	Velocity (ft/sec)	Capacity (cfs)	Description
14.0					Direct Entry,

Subcatchment 6S: EXWS-30 / C

Hydrograph

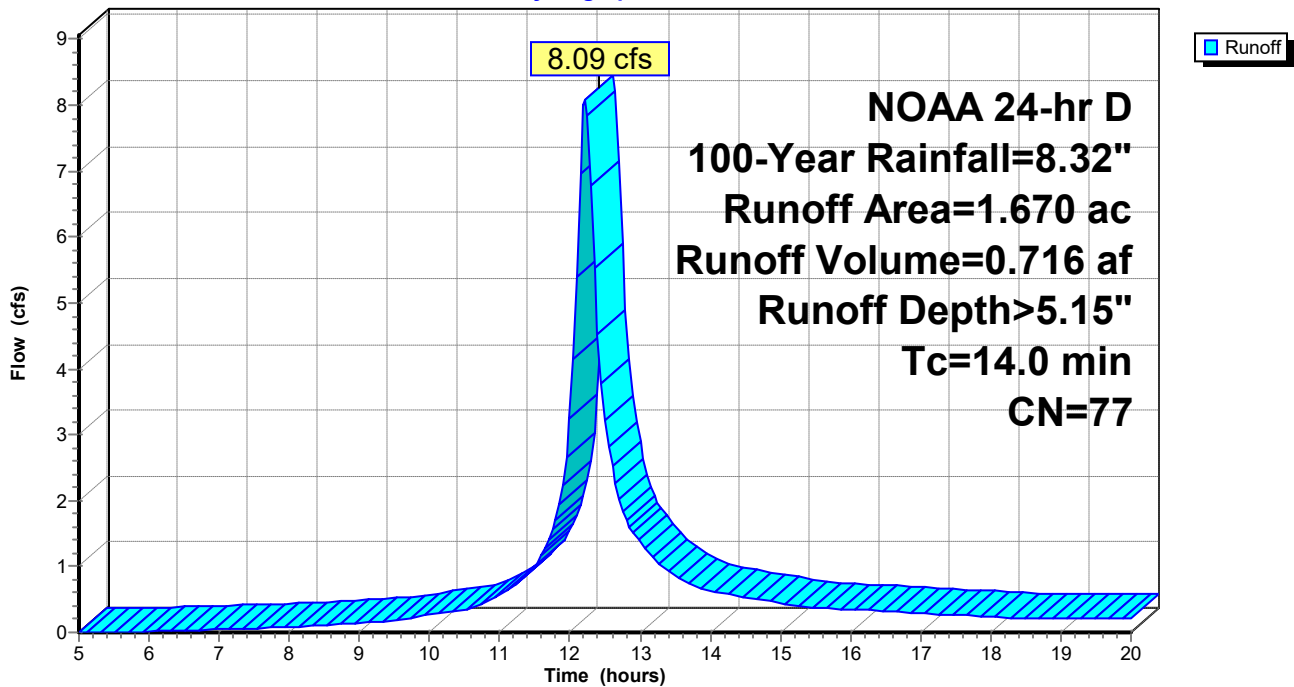

Summary for Subcatchment 7S: PRWS-10

Runoff = 9.49 cfs @ 12.15 hrs, Volume= 0.703 af, Depth> 5.27"
Routed to Link 15L : PR POA / A

Runoff by SCS TR-20 method, UH=SCS, Weighted-CN, Time Span= 5.00-20.00 hrs, dt= 0.05 hrs
NOAA 24-hr D 100-Year Rainfall=8.32"

Area (ac)	CN	Description
* 1.600	78	
1.600		100.00% Pervious Area

Tc (min)	Length (feet)	Slope (ft/ft)	Velocity (ft/sec)	Capacity (cfs)	Description
8.2					Direct Entry,

Subcatchment 7S: PRWS-10

Hydrograph

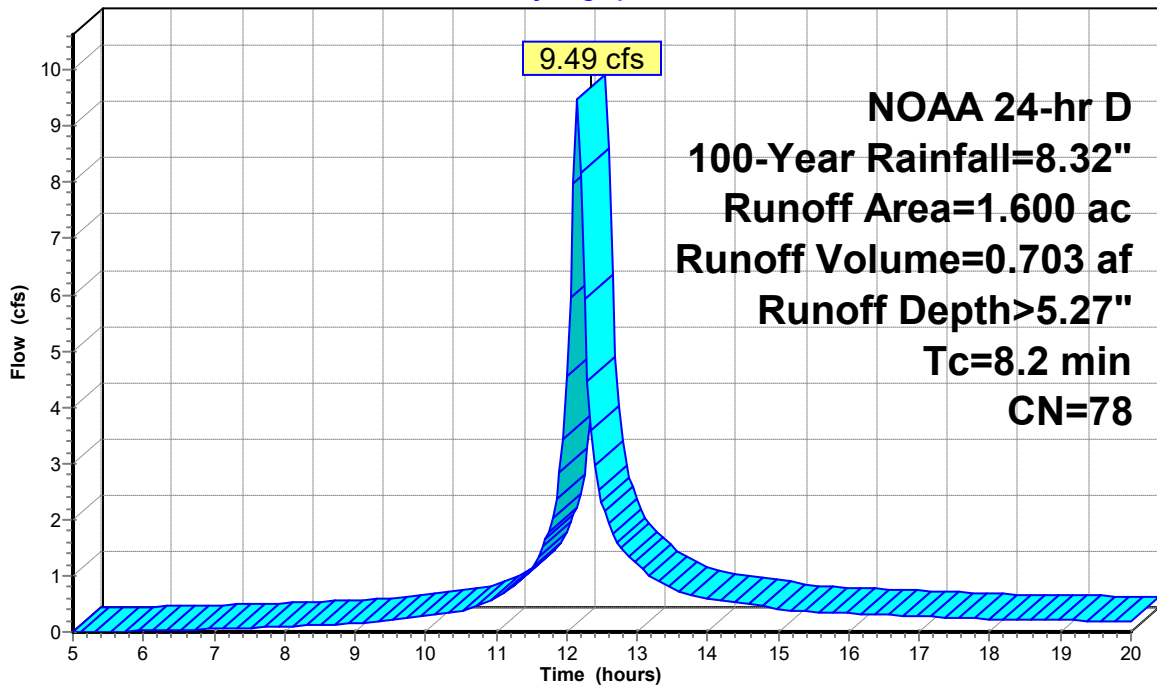

Summary for Subcatchment 8S: PRWS-11

Runoff = 43.53 cfs @ 12.54 hrs, Volume= 6.155 af, Depth> 4.64"
Routed to Link 15L : PR POA / A

Runoff by SCS TR-20 method, UH=SCS, Weighted-CN, Time Span= 5.00-20.00 hrs, dt= 0.05 hrs
NOAA 24-hr D 100-Year Rainfall=8.32"

Area (ac)	CN	Description
* 15.920	73	
15.920		100.00% Pervious Area

Tc (min)	Length (feet)	Slope (ft/ft)	Velocity (ft/sec)	Capacity (cfs)	Description
39.5					Direct Entry,

Subcatchment 8S: PRWS-11

Hydrograph

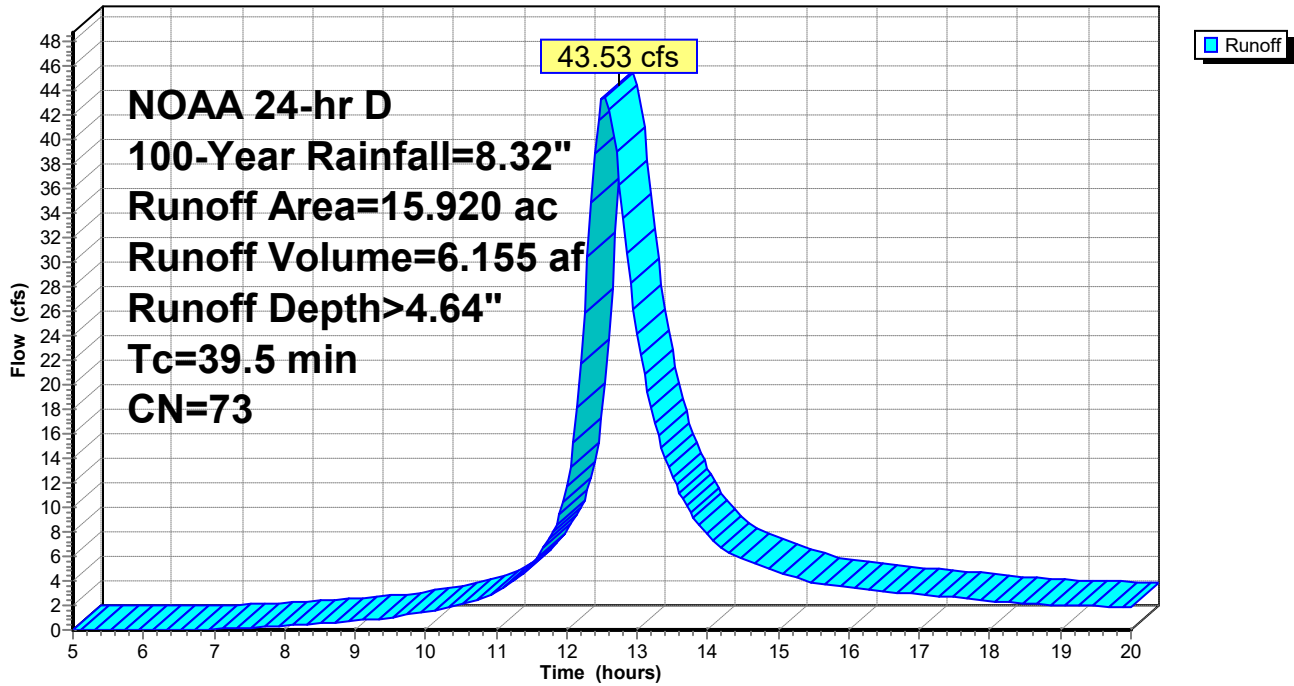

Summary for Subcatchment 10S: PRWS-20

Runoff = 12.87 cfs @ 12.24 hrs, Volume= 1.229 af, Depth> 5.72"
Routed to Link 18L : PR POA / B

Runoff by SCS TR-20 method, UH=SCS, Weighted-CN, Time Span= 5.00-20.00 hrs, dt= 0.05 hrs
NOAA 24-hr D 100-Year Rainfall=8.32"

Table with 3 columns: Area (ac), CN, Description. Row 1: 2.580, 82, 100.00% Pervious Area

Table with 7 columns: Tc (min), Length (feet), Slope (ft/ft), Velocity (ft/sec), Capacity (cfs), Description. Row 1: 15.9, Direct Entry,

Subcatchment 10S: PRWS-20

Hydrograph

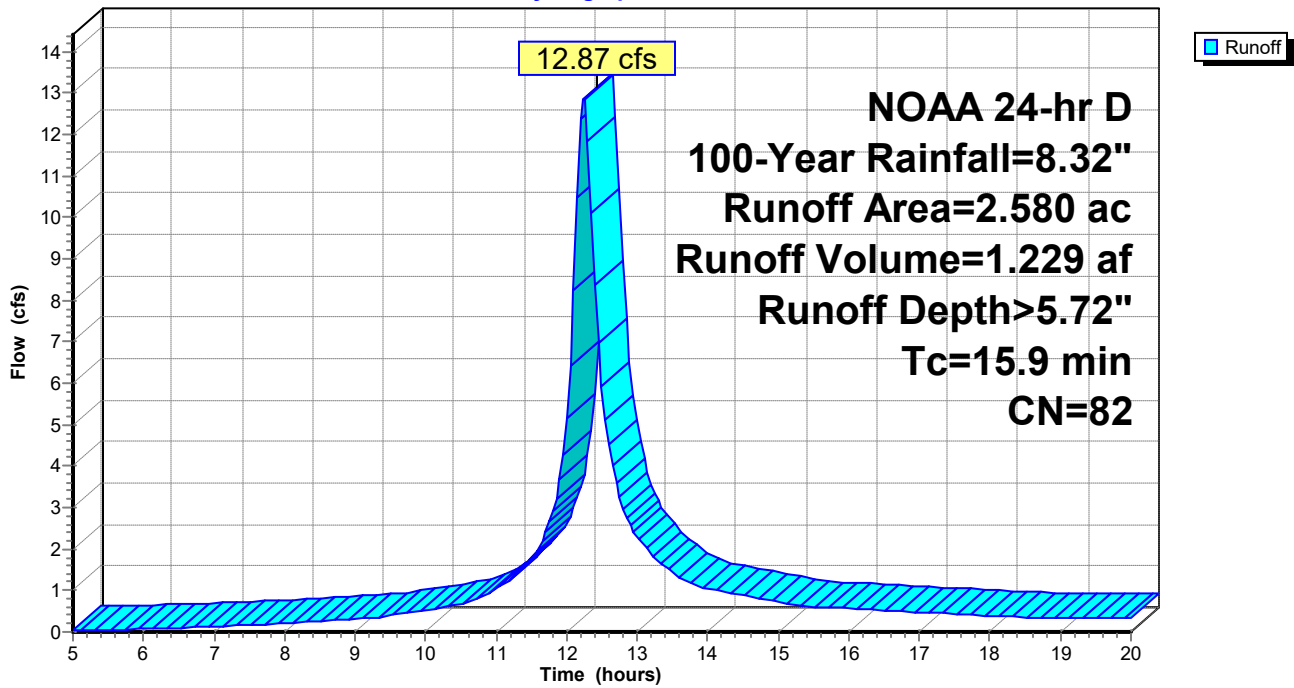

Summary for Subcatchment 11S: PRWS-21

Runoff = 18.66 cfs @ 12.16 hrs, Volume= 1.538 af, Depth> 6.50"
Routed to Pond 16P : DET 210

Runoff by SCS TR-20 method, UH=SCS, Weighted-CN, Time Span= 5.00-20.00 hrs, dt= 0.05 hrs
NOAA 24-hr D 100-Year Rainfall=8.32"

Area (ac)	CN	Description
* 2.840	89	
2.840		100.00% Pervious Area

Tc (min)	Length (feet)	Slope (ft/ft)	Velocity (ft/sec)	Capacity (cfs)	Description
9.4					Direct Entry,

Subcatchment 11S: PRWS-21

Hydrograph

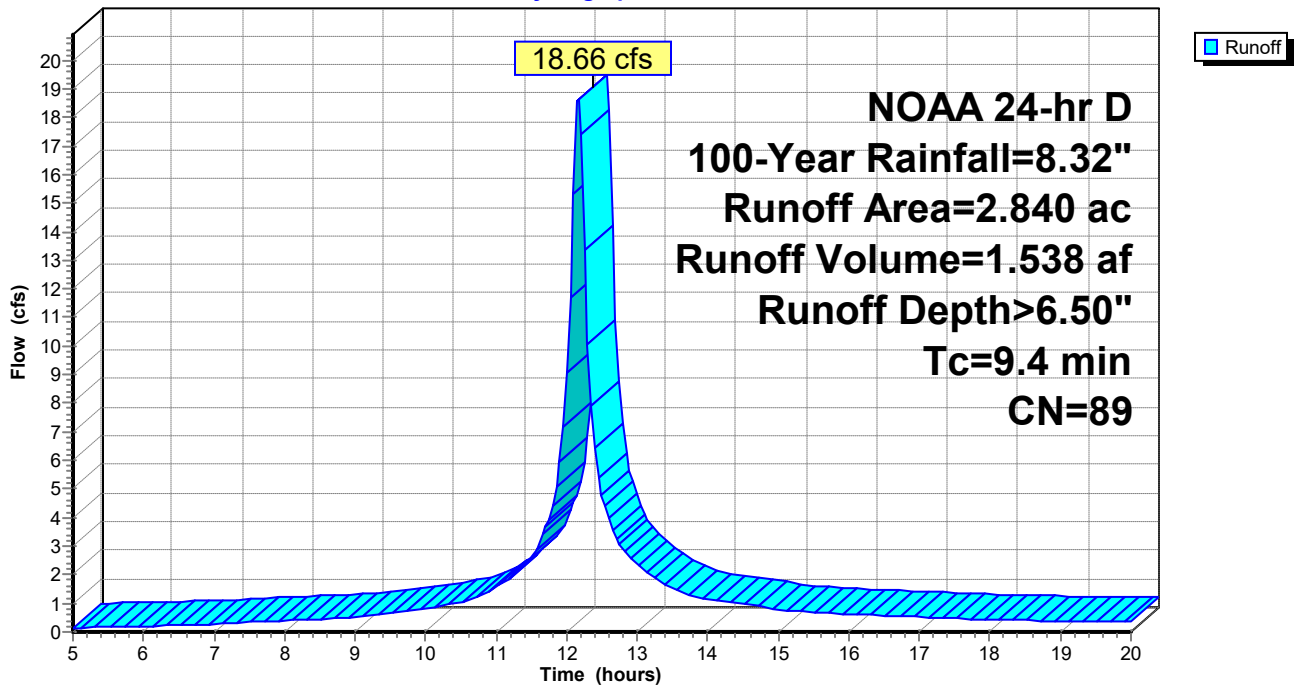

Summary for Subcatchment 12S: PRWS-22

Runoff = 4.98 cfs @ 12.17 hrs, Volume= 0.418 af, Depth> 6.60"
 Routed to Pond 17P : DET 220

Runoff by SCS TR-20 method, UH=SCS, Weighted-CN, Time Span= 5.00-20.00 hrs, dt= 0.05 hrs
 NOAA 24-hr D 100-Year Rainfall=8.32"

Area (ac)	CN	Description
* 0.760	90	
0.760		100.00% Pervious Area

Tc (min)	Length (feet)	Slope (ft/ft)	Velocity (ft/sec)	Capacity (cfs)	Description
9.7					Direct Entry,

Subcatchment 12S: PRWS-22

Hydrograph

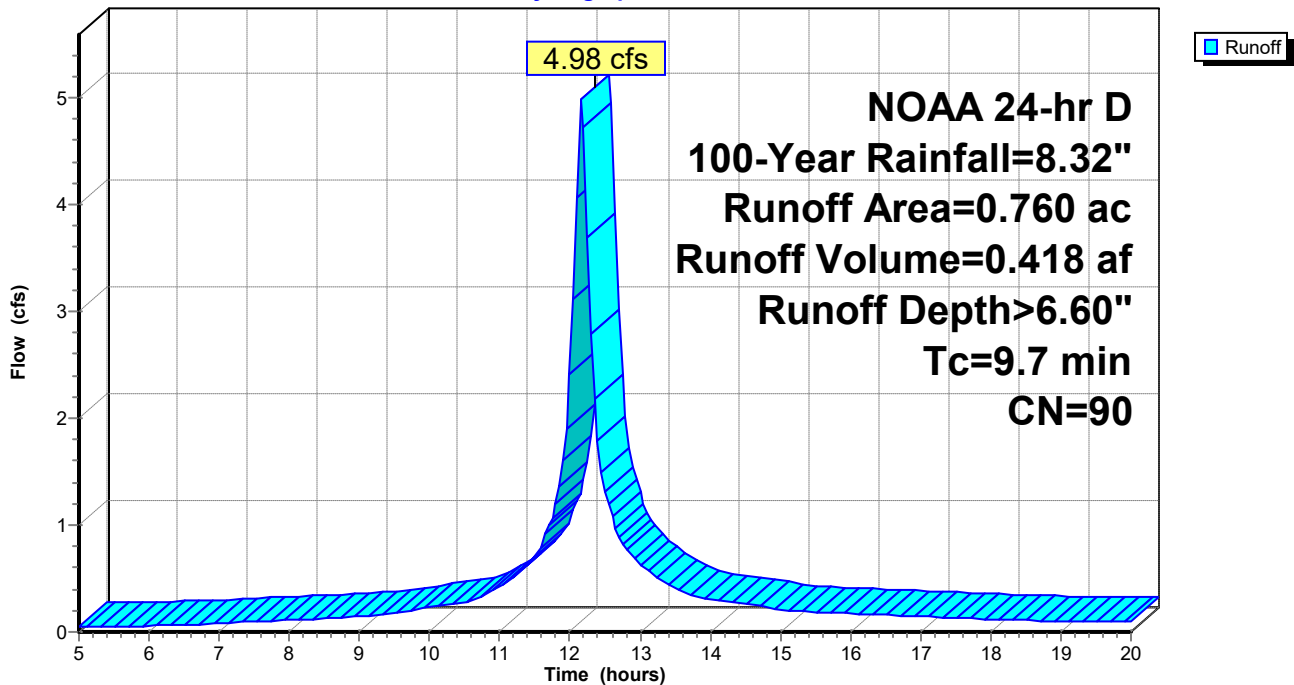

Summary for Subcatchment 13S: PRWS-30 / C

Runoff = 5.66 cfs @ 12.21 hrs, Volume= 0.495 af, Depth> 5.26"

Runoff by SCS TR-20 method, UH=SCS, Weighted-CN, Time Span= 5.00-20.00 hrs, dt= 0.05 hrs
NOAA 24-hr D 100-Year Rainfall=8.32"

Area (ac)	CN	Description
* 1.130	78	
1.130		100.00% Pervious Area

Tc (min)	Length (feet)	Slope (ft/ft)	Velocity (ft/sec)	Capacity (cfs)	Description
13.4					Direct Entry,

Subcatchment 13S: PRWS-30 / C

Hydrograph

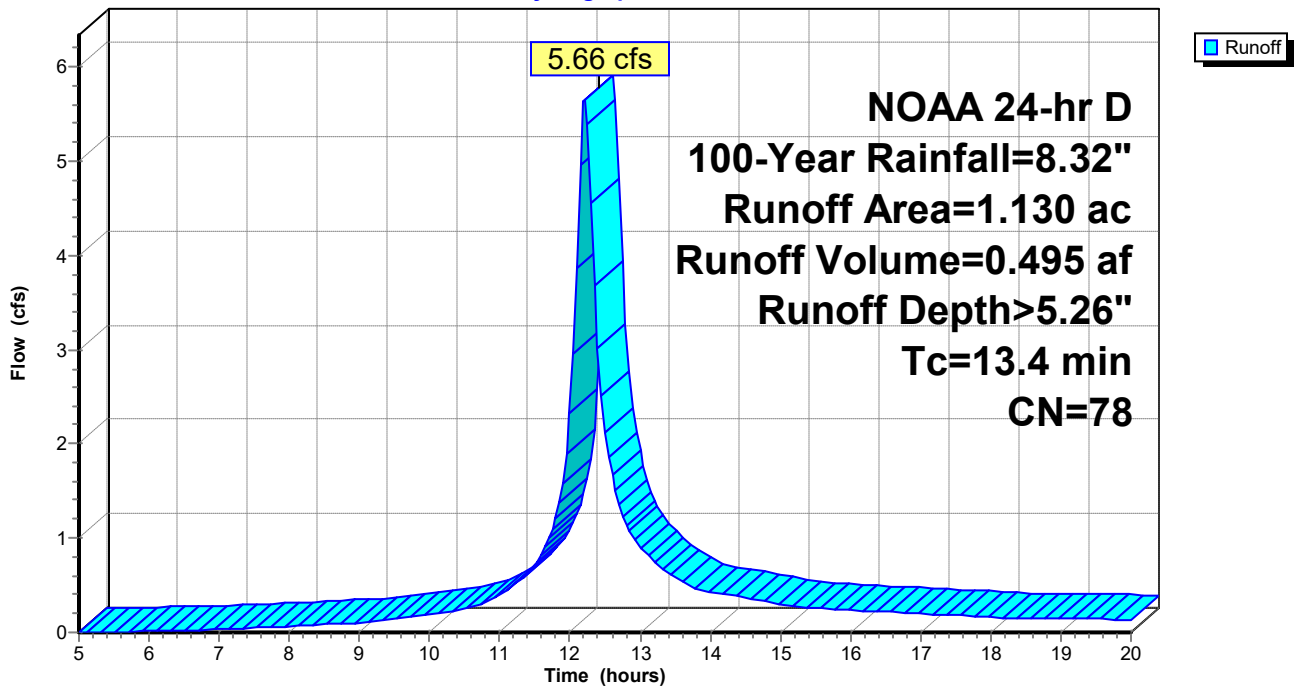

Summary for Subcatchment 20S: PRWS-14

Runoff = 2.21 cfs @ 12.15 hrs, Volume= 0.167 af, Depth> 6.07"
Routed to Pond 23P : WQ 140

Runoff by SCS TR-20 method, UH=SCS, Weighted-CN, Time Span= 5.00-20.00 hrs, dt= 0.05 hrs
NOAA 24-hr D 100-Year Rainfall=8.32"

Area (ac)	CN	Description
* 0.330	85	
0.330		100.00% Pervious Area

Tc (min)	Length (feet)	Slope (ft/ft)	Velocity (ft/sec)	Capacity (cfs)	Description
7.7					Direct Entry,

Subcatchment 20S: PRWS-14

Hydrograph

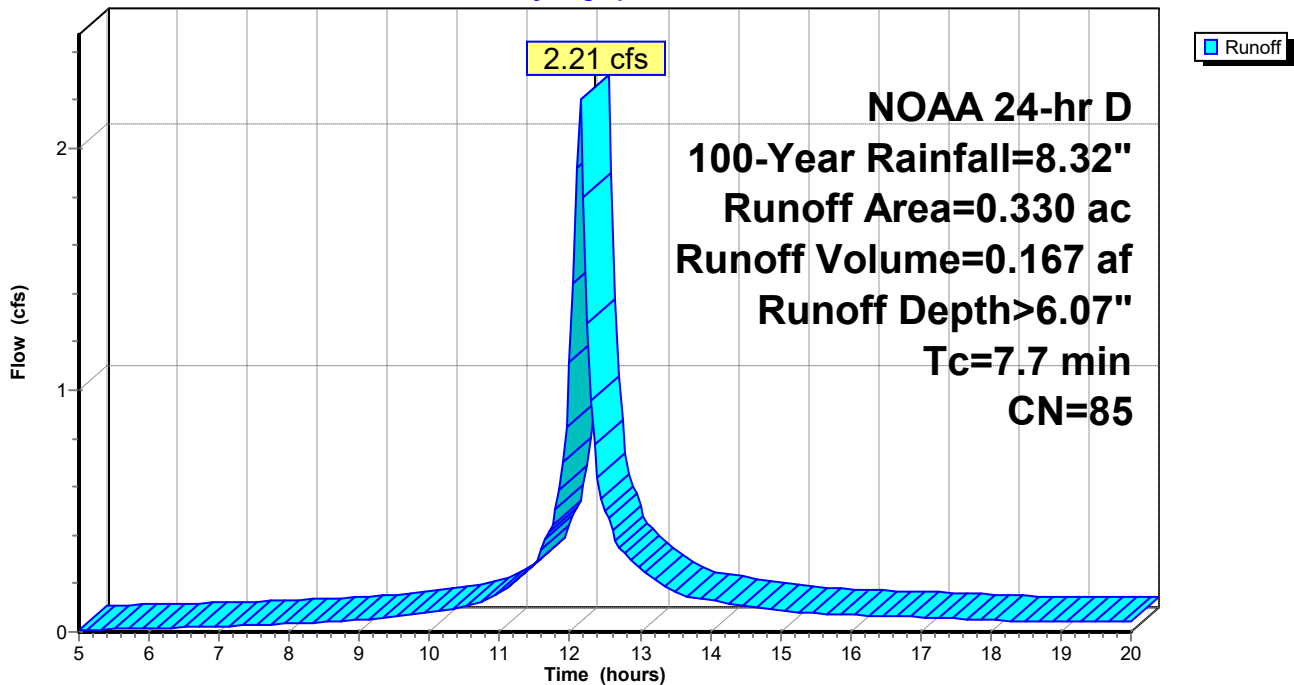

Summary for Pond 16P: DET 210

Inflow Area = 2.840 ac, 0.00% Impervious, Inflow Depth > 6.50" for 100-Year event
 Inflow = 18.66 cfs @ 12.16 hrs, Volume= 1.538 af
 Outflow = 7.26 cfs @ 12.37 hrs, Volume= 1.416 af, Atten= 61%, Lag= 12.7 min
 Discarded = 0.72 cfs @ 12.37 hrs, Volume= 0.642 af
 Primary = 6.54 cfs @ 12.37 hrs, Volume= 0.774 af
 Routed to Link 18L : PR POA / B
 Secondary = 0.00 cfs @ 5.00 hrs, Volume= 0.000 af
 Routed to Link 18L : PR POA / B

Routing by Stor-Ind method, Time Span= 5.00-20.00 hrs, dt= 0.05 hrs
 Peak Elev= 817.09' @ 12.37 hrs Surf.Area= 10,419 sf Storage= 18,784 cf

Plug-Flow detention time= 63.1 min calculated for 1.415 af (92% of inflow)
 Center-of-Mass det. time= 33.7 min (787.3 - 753.5)

Volume	Invert	Avail.Storage	Storage Description		
#1	815.00'	28,886 cf	Custom Stage Data (Conic) Listed below (Recalc)		
Elevation (feet)	Surf.Area (sq-ft)	Inc.Store (cubic-feet)	Cum.Store (cubic-feet)	Wet.Area (sq-ft)	
815.00	7,672	0	0	7,672	
816.00	8,907	8,282	8,282	8,948	
817.00	10,296	9,593	17,875	10,380	
818.00	11,741	11,011	28,886	11,872	

Device	Routing	Invert	Outlet Devices	
#1	Discarded	815.00'	3.000 in/hr Exfiltration over Surface area	
#2	Primary	814.50'	15.0" Round Culvert L= 127.0' CPP, projecting, no headwall, Ke= 0.900 Inlet / Outlet Invert= 814.50' / 806.40' S= 0.0638 '/' Cc= 0.900 n= 0.012, Flow Area= 1.23 sf	
#3	Device 2	815.90'	14.0' long Sharp-Crested Rectangular Weir 2 End Contraction(s)	
#4	Secondary	817.20'	10.0' long + 3.0 ' SideZ x 8.0' breadth Broad-Crested Rectangular Weir Head (feet) 0.20 0.40 0.60 0.80 1.00 1.20 1.40 1.60 1.80 2.00 2.50 3.00 3.50 4.00 4.50 5.00 5.50 Coef. (English) 2.43 2.54 2.70 2.69 2.68 2.68 2.66 2.64 2.64 2.64 2.65 2.65 2.66 2.66 2.68 2.70 2.74	

Discarded OutFlow Max=0.72 cfs @ 12.37 hrs HW=817.08' (Free Discharge)
 ↑1=Exfiltration (Exfiltration Controls 0.72 cfs)

Primary OutFlow Max=6.53 cfs @ 12.37 hrs HW=817.08' (Free Discharge)
 ↑2=Culvert (Inlet Controls 6.53 cfs @ 5.32 fps)
 ↑3=Sharp-Crested Rectangular Weir (Passes 6.53 cfs of 57.97 cfs potential flow)

Secondary OutFlow Max=0.00 cfs @ 5.00 hrs HW=815.00' (Free Discharge)
 ↑4=Broad-Crested Rectangular Weir (Controls 0.00 cfs)

Pond 16P: DET 210

Hydrograph

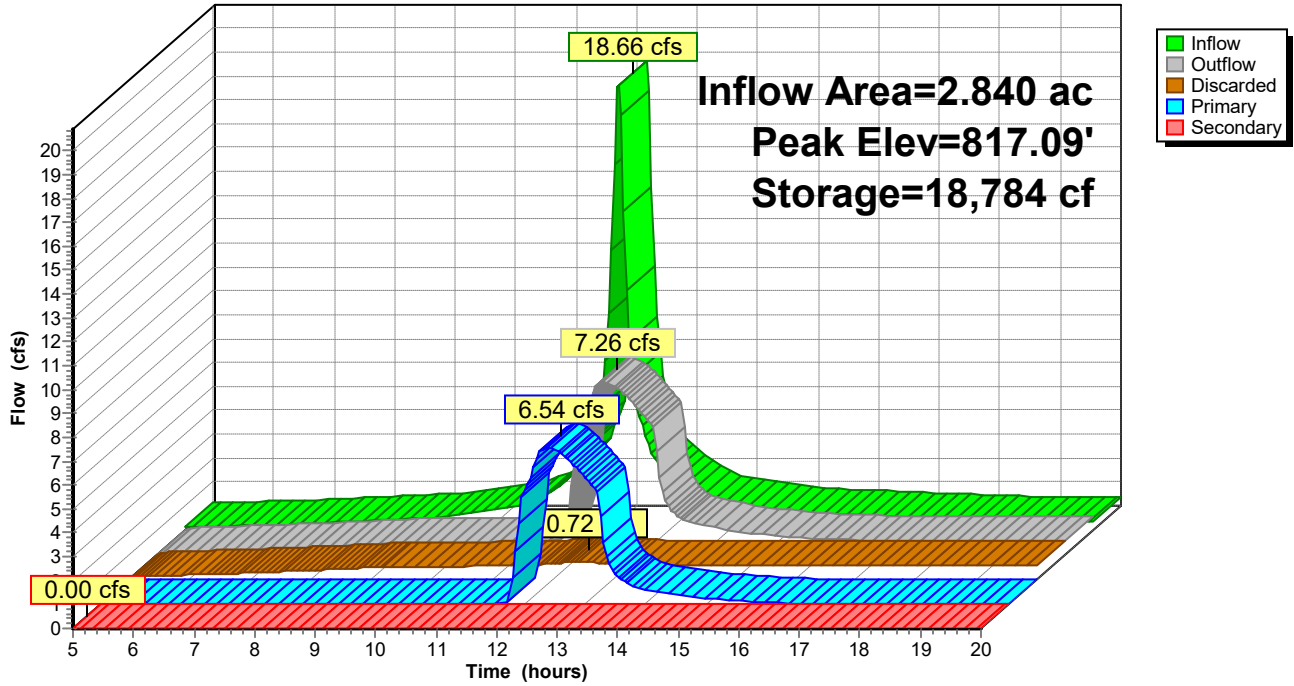

Summary for Pond 17P: DET 220

Inflow Area = 0.760 ac, 0.00% Impervious, Inflow Depth > 6.60" for 100-Year event
 Inflow = 4.98 cfs @ 12.17 hrs, Volume= 0.418 af
 Outflow = 4.83 cfs @ 12.19 hrs, Volume= 0.364 af, Atten= 3%, Lag= 1.7 min
 Discarded = 0.10 cfs @ 12.19 hrs, Volume= 0.093 af
 Primary = 4.73 cfs @ 12.19 hrs, Volume= 0.271 af
 Routed to Link 18L : PR POA / B
 Secondary = 0.00 cfs @ 5.00 hrs, Volume= 0.000 af
 Routed to Link 18L : PR POA / B

Routing by Stor-Ind method, Time Span= 5.00-20.00 hrs, dt= 0.05 hrs
 Peak Elev= 803.00' @ 12.19 hrs Surf.Area= 2,808 sf Storage= 4,136 cf

Plug-Flow detention time= 80.5 min calculated for 0.363 af (87% of inflow)
 Center-of-Mass det. time= 38.9 min (790.6 - 751.7)

Volume	Invert	Avail.Storage	Storage Description		
#1	801.00'	7,722 cf	Custom Stage Data (Conic) Listed below (Recalc)		
Elevation (feet)	Surf.Area (sq-ft)	Inc.Store (cubic-feet)	Cum.Store (cubic-feet)	Wet.Area (sq-ft)	
801.00	1,433	0	0	1,433	
802.00	2,039	1,727	1,727	2,057	
803.00	2,810	2,414	4,141	2,847	
804.00	4,412	3,581	7,722	4,463	

Device	Routing	Invert	Outlet Devices	
#1	Discarded	801.00'	1.580 in/hr Exfiltration over Surface area	
#2	Primary	800.50'	15.0" Round Culvert L= 39.0' CPP, projecting, no headwall, Ke= 0.900 Inlet / Outlet Invert= 800.50' / 800.00' S= 0.0128 '/' Cc= 0.900 n= 0.012, Flow Area= 1.23 sf	
#3	Device 2	802.20'	6.0" Vert. Orifice/Grate C= 0.600 Limited to weir flow at low heads	
#4	Device 2	802.80'	14.0' long Sharp-Crested Rectangular Weir 2 End Contraction(s)	
#5	Secondary	803.00'	10.0' long + 3.0 ' SideZ x 8.0' breadth Broad-Crested Rectangular Weir Head (feet) 0.20 0.40 0.60 0.80 1.00 1.20 1.40 1.60 1.80 2.00 2.50 3.00 3.50 4.00 4.50 5.00 5.50 Coef. (English) 2.43 2.54 2.70 2.69 2.68 2.68 2.66 2.64 2.64 2.64 2.65 2.65 2.66 2.66 2.68 2.70 2.74	

Discarded OutFlow Max=0.10 cfs @ 12.19 hrs HW=803.00' (Free Discharge)
 ↑1=Exfiltration (Exfiltration Controls 0.10 cfs)

Primary OutFlow Max=4.67 cfs @ 12.19 hrs HW=803.00' (Free Discharge)
 ↑2=Culvert (Passes 4.67 cfs of 6.38 cfs potential flow)
 ↑3=Orifice/Grate (Orifice Controls 0.70 cfs @ 3.56 fps)
 ↑4=Sharp-Crested Rectangular Weir (Weir Controls 3.97 cfs @ 1.45 fps)

Secondary OutFlow Max=0.00 cfs @ 5.00 hrs HW=801.00' (Free Discharge)
 ↑5=Broad-Crested Rectangular Weir (Controls 0.00 cfs)

Pond 17P: DET 220

Hydrograph

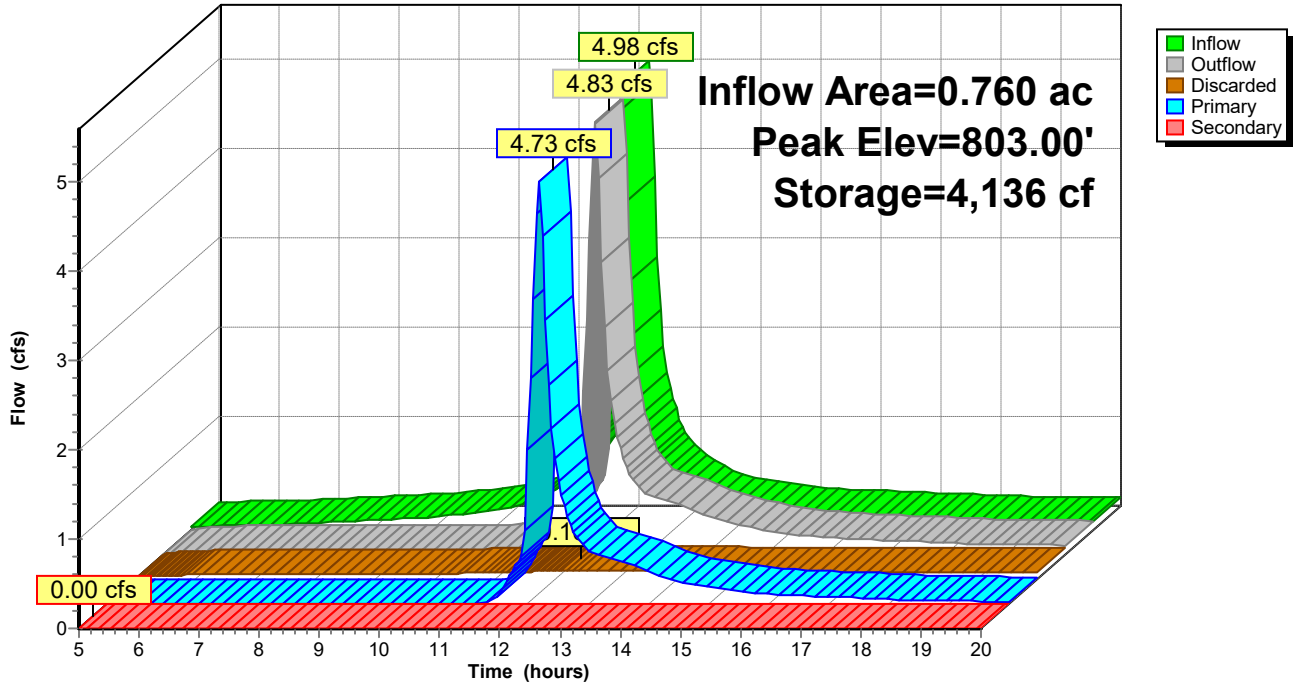

Summary for Pond 23P: WQ 140

Inflow Area = 0.330 ac, 0.00% Impervious, Inflow Depth > 6.07" for 100-Year event
 Inflow = 2.21 cfs @ 12.15 hrs, Volume= 0.167 af
 Outflow = 2.13 cfs @ 12.16 hrs, Volume= 0.144 af, Atten= 4%, Lag= 1.1 min
 Primary = 2.13 cfs @ 12.16 hrs, Volume= 0.144 af
 Routed to Link 15L : PR POA / A

Routing by Stor-Ind method, Time Span= 5.00-20.00 hrs, dt= 0.05 hrs
 Peak Elev= 838.69' @ 12.16 hrs Surf.Area= 1,165 sf Storage= 1,189 cf

Plug-Flow detention time= 77.5 min calculated for 0.144 af (86% of inflow)
 Center-of-Mass det. time= 34.8 min (795.4 - 760.6)

Volume	Invert	Avail.Storage	Storage Description
#1	837.50'	1,554 cf	Custom Stage Data (Prismatic) Listed below (Recalc)
Elevation (feet)	Surf.Area (sq-ft)	Inc.Store (cubic-feet)	Cum.Store (cubic-feet)
837.50	801	0	0
838.00	964	441	441
838.50	1,143	527	968
839.00	1,200	586	1,554

Device	Routing	Invert	Outlet Devices
#1	Primary	838.50'	10.0' long + 3.0 ' SideZ x 8.0' breadth Broad-Crested Rectangular Weir Head (feet) 0.20 0.40 0.60 0.80 1.00 1.20 1.40 1.60 1.80 2.00 2.50 3.00 3.50 4.00 4.50 5.00 5.50 Coef. (English) 2.43 2.54 2.70 2.69 2.68 2.68 2.66 2.64 2.64 2.64 2.65 2.65 2.66 2.66 2.68 2.70 2.74

Primary OutFlow Max=2.07 cfs @ 12.16 hrs HW=838.69' (Free Discharge)
 ↑1=**Broad-Crested Rectangular Weir** (Weir Controls 2.07 cfs @ 1.04 fps)

Pond 23P: WQ 140

Hydrograph

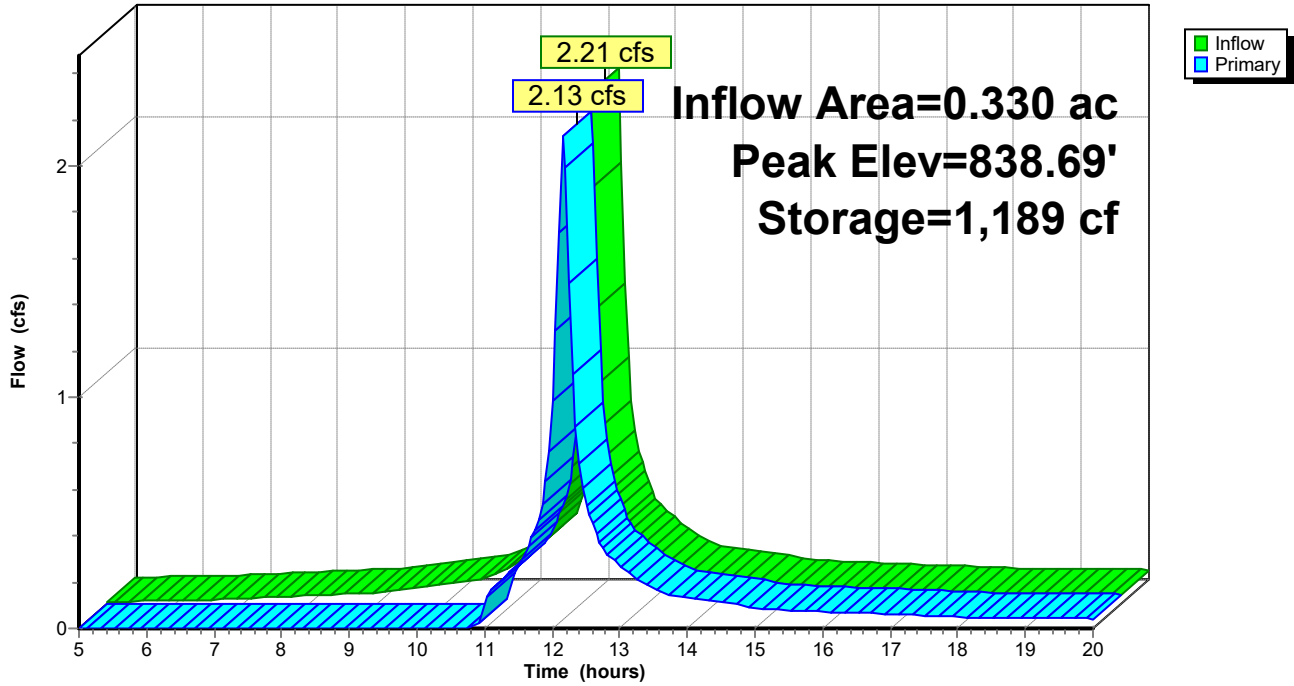

Summary for Link 4L: EX POA / A

Inflow Area = 18.510 ac, 0.00% Impervious, Inflow Depth > 4.69" for 100-Year event
Inflow = 48.11 cfs @ 12.52 hrs, Volume= 7.236 af
Primary = 48.11 cfs @ 12.52 hrs, Volume= 7.236 af, Atten= 0%, Lag= 0.0 min

Primary outflow = Inflow, Time Span= 5.00-20.00 hrs, dt= 0.05 hrs

Link 4L: EX POA / A

Hydrograph

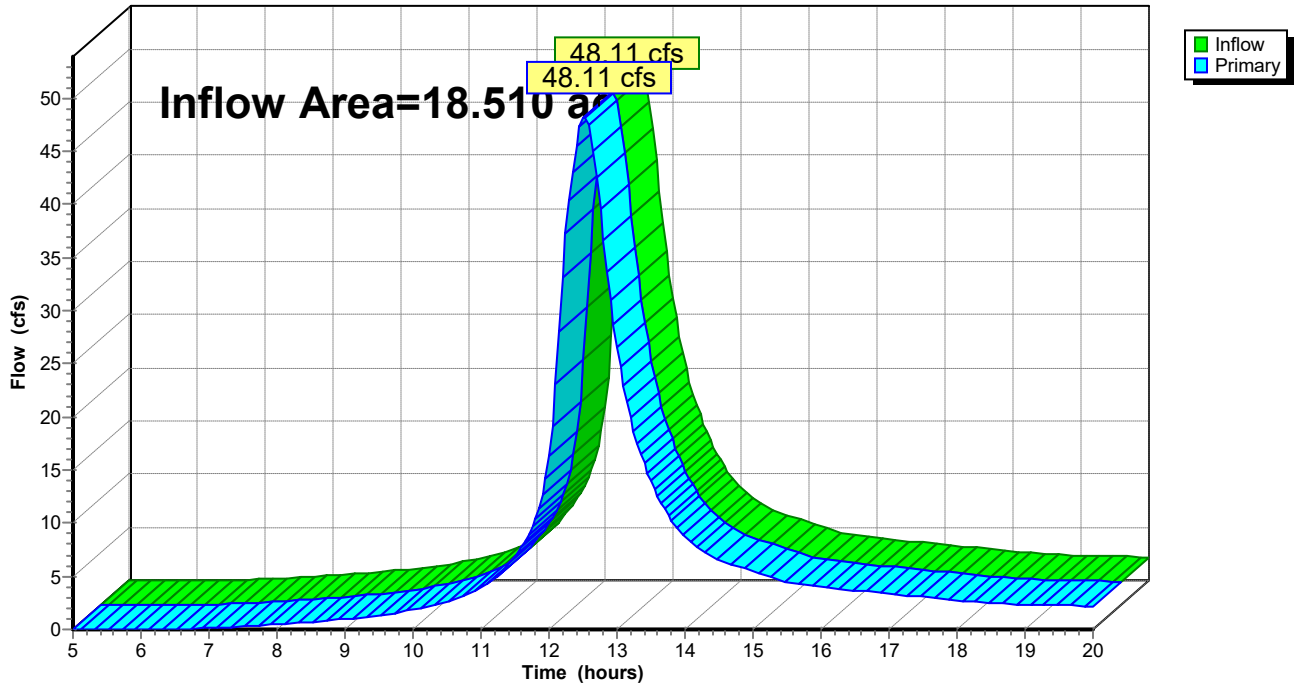

Summary for Link 15L: PR POA / A

Inflow Area = 17.850 ac, 0.00% Impervious, Inflow Depth > 4.71" for 100-Year event
Inflow = 46.25 cfs @ 12.53 hrs, Volume= 7.002 af
Primary = 46.25 cfs @ 12.53 hrs, Volume= 7.002 af, Atten= 0%, Lag= 0.0 min

Primary outflow = Inflow, Time Span= 5.00-20.00 hrs, dt= 0.05 hrs

Link 15L: PR POA / A

Hydrograph

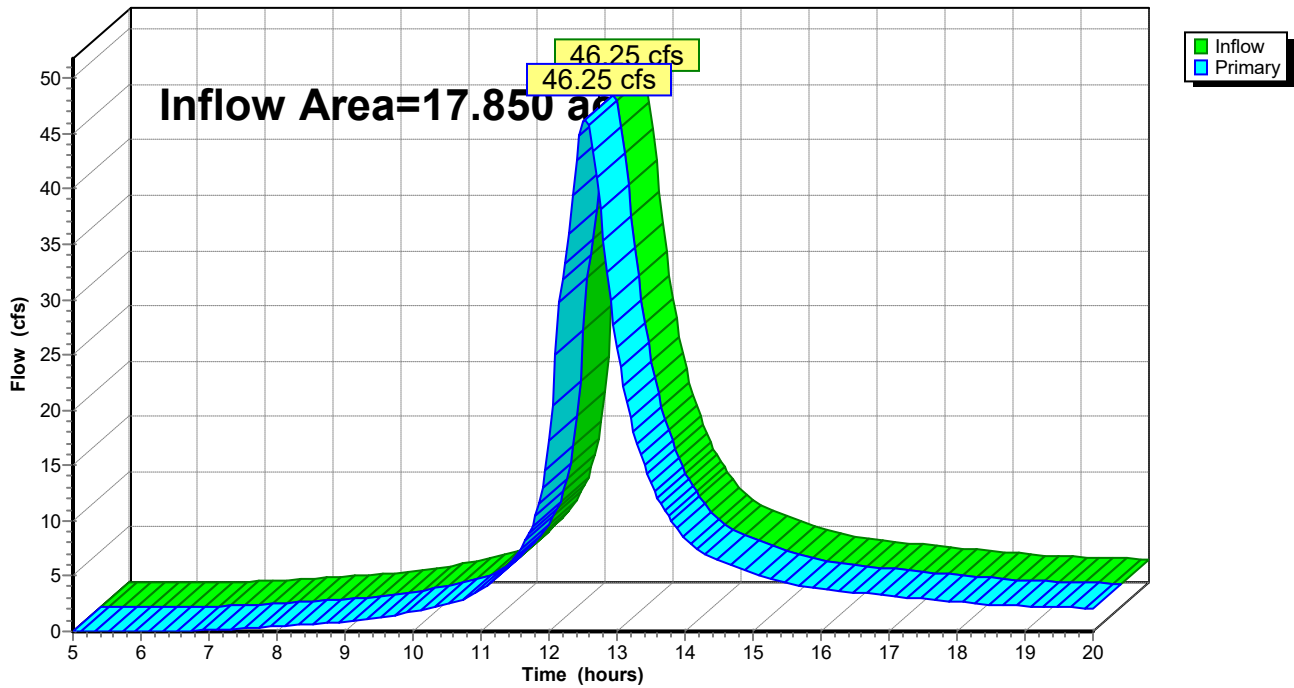

Summary for Link 18L: PR POA / B

Inflow Area = 6.180 ac, 0.00% Impervious, Inflow Depth > 4.42" for 100-Year event
Inflow = 23.48 cfs @ 12.23 hrs, Volume= 2.275 af
Primary = 23.48 cfs @ 12.23 hrs, Volume= 2.275 af, Atten= 0%, Lag= 0.0 min

Primary outflow = Inflow, Time Span= 5.00-20.00 hrs, dt= 0.05 hrs

Link 18L: PR POA / B

Hydrograph

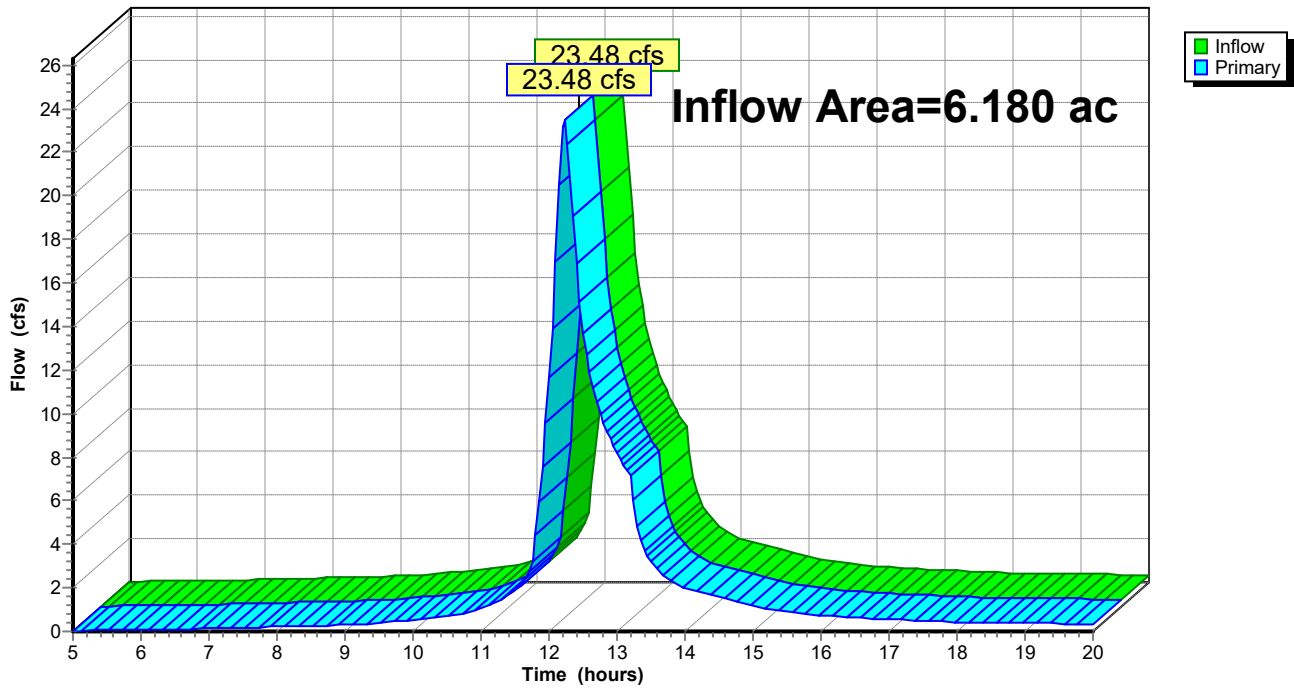

Appendix H

Watershed Maps

Wake Robin Inn Redevelopment

104 & 106 Sharon Road, Salisbury, Connecticut

Drainage Report

Prepared for:
Aradev LLC
352 Atlantic Avenue, Unit 2
Brooklyn, NY 11217

SLR Project No.: 141.22100.00001

April 25, 2025

Revised July 28, 2025



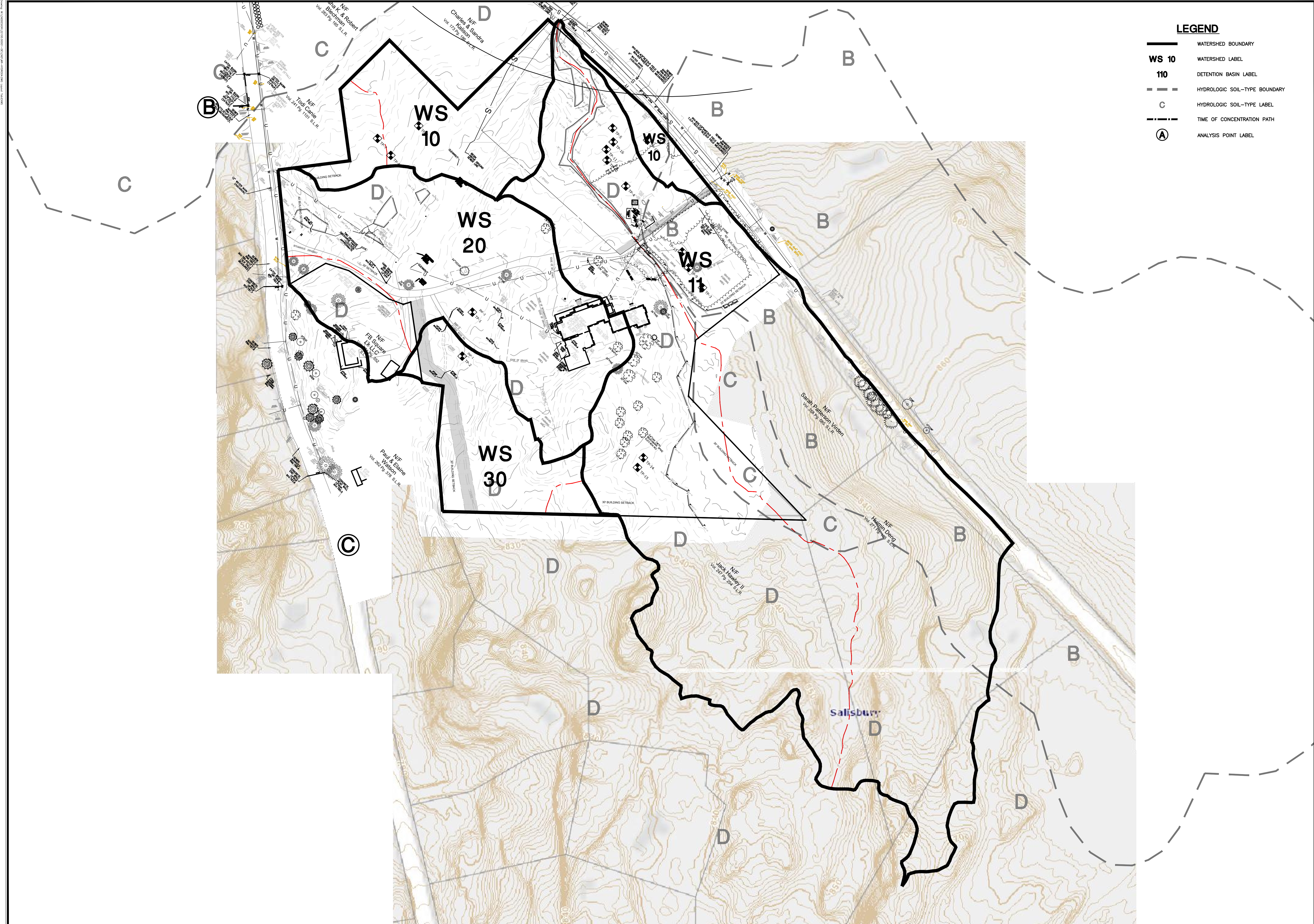

LEGEND

- WATERSHED BOUNDARY
- WS 10** WATERSHED LABEL
- 110** DETENTION BASIN LABEL
- HYDROLOGIC SOIL-TYPE BOUNDARY
- C** HYDROLOGIC SOIL-TYPE LABEL
- TIME OF CONCENTRATION PATH
- (A)** ANALYSIS POINT LABEL

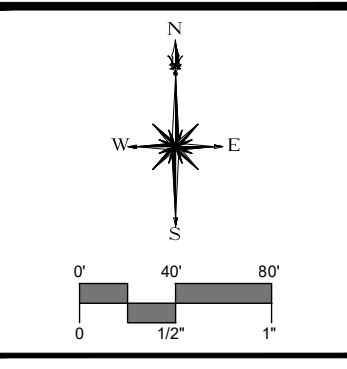

DESCRIPTION	DATE	BY
ENGINEERING COMMENTS	07/25/2025	MCB

WATERSHED MAP - EXISTING CONDITIONS
WAKE ROBIN INN REDEVELOPMENT
 104 & 106 SHARON ROAD
 SALISBURY, CONNECTICUT

DESIGNED	DRAWN	TDR
SCALE		
1"=80'		
DATE		
APRIL 29, 2025		
PROJECT NO.		
22100.00001		
SHEET NO.		
1 OF 2		

EXWS

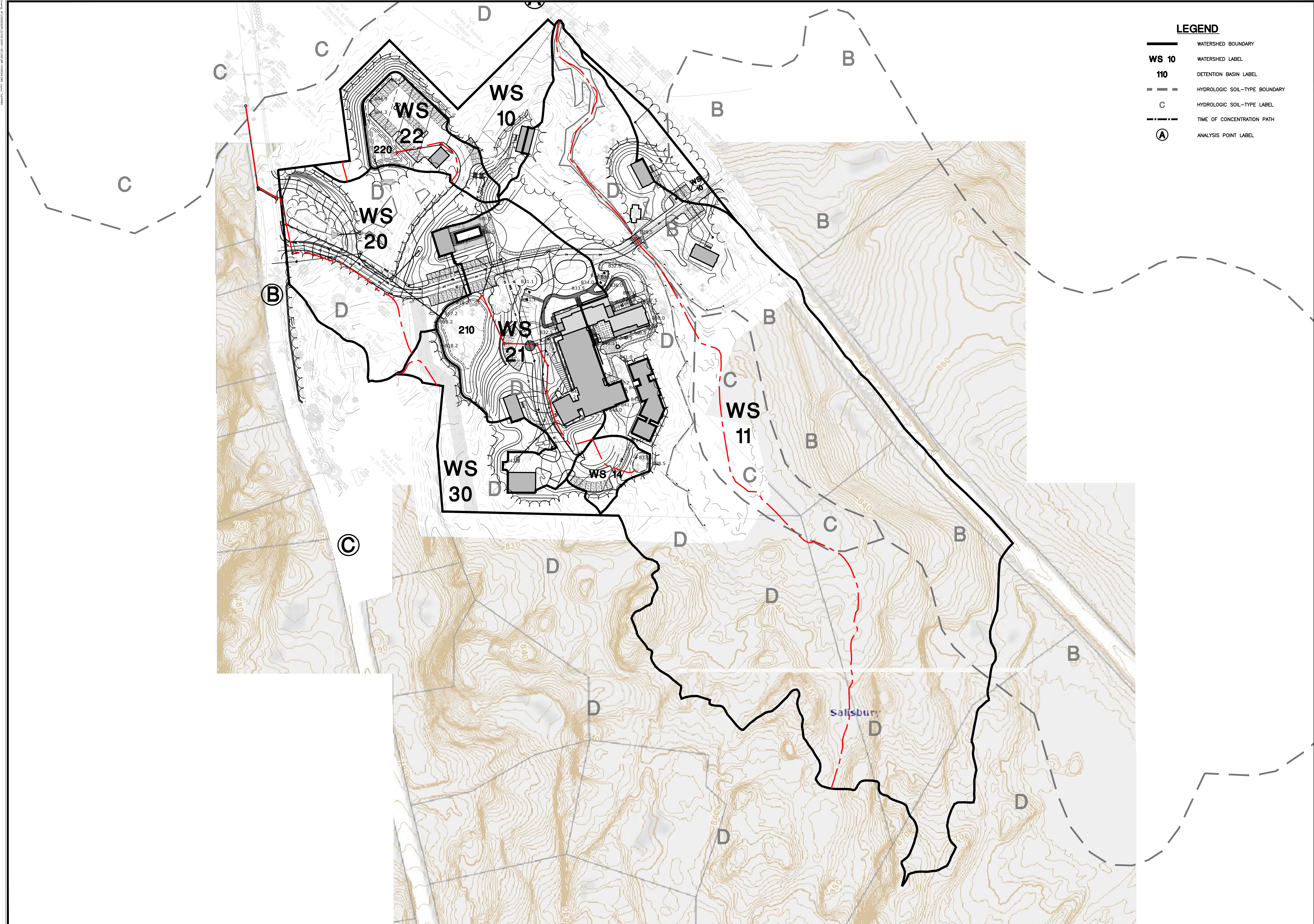

LEGEND

- WATERSHED BOUNDARY
- WS 10** WATERSHED LABEL
- 110** DETENTION BASIN LABEL
- HYDROLOGIC SOIL-TYPE BOUNDARY
- C** HYDROLOGIC SOIL-TYPE LABEL
- TIME OF CONCENTRATION PATH
- (A)** ANALYSIS POINT LABEL

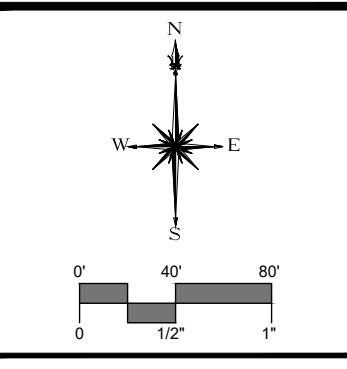

DESCRIPTION	DATE	BY
ENGINEERING COMMENTS	07/29/2025	MCB

WATERSHED MAP - PROPOSED CONDITIONS
WAKE ROBIN INN REDEVELOPMENT
 104 & 106 SHARON ROAD
 SALISBURY, CONNECTICUT

MCB	MCB	TDR
DESIGNED	DRAWN	CHECKED
SCALE: 1"=80'		
DATE: APRIL 29, 2025		
PROJECT NO: 22100.00001		
SHEET NO: 2 OF 2		

PRWS



Appendix I Post-Construction Operation and Maintenance Manual

Wake Robin Inn Redevelopment

104 & 106 Sharon Road, Salisbury, Connecticut

Drainage Report

Prepared for:
Aradev LLC
352 Atlantic Avenue, Unit 2
Brooklyn, NY 11217

SLR Project No.: 141.22100.00001

April 25, 2025

Revised July 28, 2025





Postconstruction Stormwater Management Operation and Maintenance Plan

Wake Robin Inn Redevelopment

Aradev LLC

352 Atlantic Avenue, Unit 2
Brooklyn, NY 11217

Prepared by:

SLR International Corporation

99 Realty Drive, Cheshire, Connecticut, 06410

SLR Project No.: 141.22100.00001

July 28, 2025

1.0 Introduction

After construction is completed, stormwater systems on the property will need to be periodically maintained. The stormwater system consists of storm drainage piping, catch basins and yard drains, manholes, outlet control structures, and stormwater detention and water quality basins.

To ensure optimal performance of the system, the following stormwater maintenance program has been established. This manual provides an outline of the operation procedures but may be adjusted based upon specific site conditions.

A representative of Aradev, LLC or designee will be responsible for the maintenance of stormwater control structures. The name and contact information for this representative are to be determined.

2.0 Stormwater System Elements

2.1 Parking Area Surface Cleaning

All paved parking areas shall be swept at least once per year, in spring as soon as possible after snow melt and following winter activities such as sanding to capture sand and debris before it is washed into the storm drainage system.

2.2 Catch Basins and Yard Drains (Inlets)

Drain inlets are designed with 2-foot minimum depth sumps for collecting coarse sediment. All inlets should be inspected two times per year, typically when the site is swept in the spring after winter sanding and in the fall after all the leaves have fallen.

Sediment should be removed when it extends to within 6 inches of the outlet pipe invert or not less than once per year. Cleanout with a vacuum truck is generally the best and most convenient method. The sediment shall be disposed of in an approved offsite location in accordance with Town and State requirements.

2.3 Storm Drainage Pipes and Structures

The stormwater system shall be inspected at least twice annually. Debris shall be cleaned out as required, and any accumulated sand, dirt and debris shall be disposed of off-site in a proper manner. All storm pipes shall be kept in proper working condition. Any structural damage to catch basins, yard drains, manholes or pipes, or other indication of malfunction will be reported to the property manager and repaired as necessary.

2.4 Flared End Sections with Riprap Outlets

The area should be inspected at least semi-annually and after substantial rainfall events. The area shall be cleared of all sediment deposits and invasive plant species. Debris and accumulated sediment shall be cleaned out as required. Damage and deterioration of the area shall be repaired immediately.

2.5 Outlet Control Structures

Outlet control structures shall be inspected monthly. Debris and sediment within the structure shall be removed as needed or at least once per year between May 1 and September 15.

2.6 Stormwater Detention and Water Quality Basins

The stormwater basins should be maintained so that the systems can effectively treat contributing stormwater runoff.

1. The stormwater basins shall be cleaned of debris and sediment upon the completion of construction.
2. The stormwater basins shall be inspected during spring cleanup and again just prior to the winter season. All dead plants and missing mulch shall be replaced, and any necessary pruning of vegetation shall be completed.
3. The surface of the stormwater basins shall be inspected on a quarterly basis after the first 6 months of successful operation and after heavy runoff events (i.e., >3.0" in a 24-hour period). One inspection shall occur immediately following the completion of the winter sanding and sweeping operations, and one shall occur just prior to the winter season. Any accumulated debris and sediment shall be removed.

2.7 Proprietary Hydrodynamic Separators

The hydrodynamic separators shall be inspected and maintained yearly, or more frequently as required. Accumulated sediment shall be removed through a manhole located at the top of the separator and shall be disposed of in a proper manner. The units should be inspected and maintained in accordance with the manufacturer's specifications.

2.8 Lawn and Vegetated Areas

Vegetated cover shall be maintained on all earth surfaces to minimize soil erosion. Use of fertilizer should be minimal, and it should be applied using prudent application procedures.

3.0 Inspection Procedures

Inventory sheets shall be created to note any noncompliance during each inspection. Fill out notes according to the attached requirements of each structure, noting shortcomings, problems, and required maintenance on each.

Item	Date of Inspection and Required Maintenance	Maintenance to be Provided/Comments	Date Maintenance Complete
Parking Area Surface Cleaning			
Catch Basins and Yard Drains			
Storm Drainage Pipes and Structures			
Flared End Sections with Riprap Outlets (Riprap Splash Pad)			
Outlet Control Structures			
Stormwater Basins			

Inspected by: _____ Date: _____

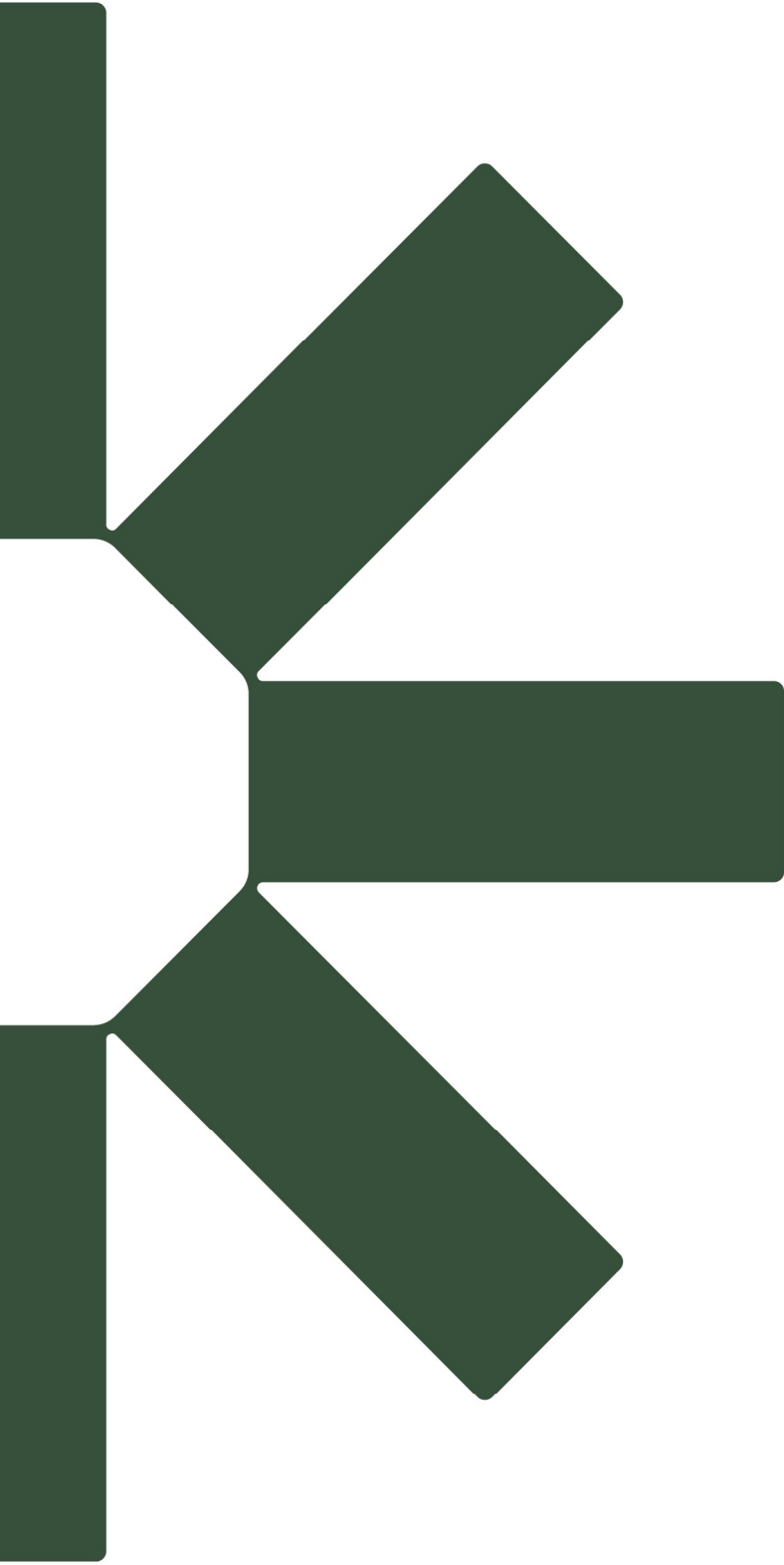

Making Sustainability Happen